

Radiation Biology, Protection and Applications (FS2018)

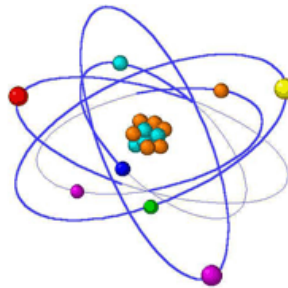

Radiation Shielding (Week 11) (supplementary)

Pavel Frajtag

26.11. 2018

- ❑ Concept and Basics
- ❑ Shielding of Alphas and Heavy Charged Particles
- ❑ Shielding of Beta Sources
- ❑ Shielding of Photons
 - Attenuation of narrow beams
 - Attenuation of broad beams: scattering and buildup factors
 - Distributed Sources
- ❑ Shielding of Protons and Light Ion Sources
- ❑ Shielding of Neutrons
- ❑ Monte Carlo Methods

The Concept of Radiation Shielding

- ☐ Purpose of radiation shielding:
 - Reduce the radiation exposure to persons and equipment.
 - Can be used to control radiation and thus is an **important aspect of Radiation Protection**.
- ☐ Radiation shielding is **based upon the mechanisms by which different radiations interact** in an absorbing medium.
- ☐ **Radiation shielding is a very complex discipline:**
 - There are many radiation sources.
 - There is a wealth of materials and geometric configurations.

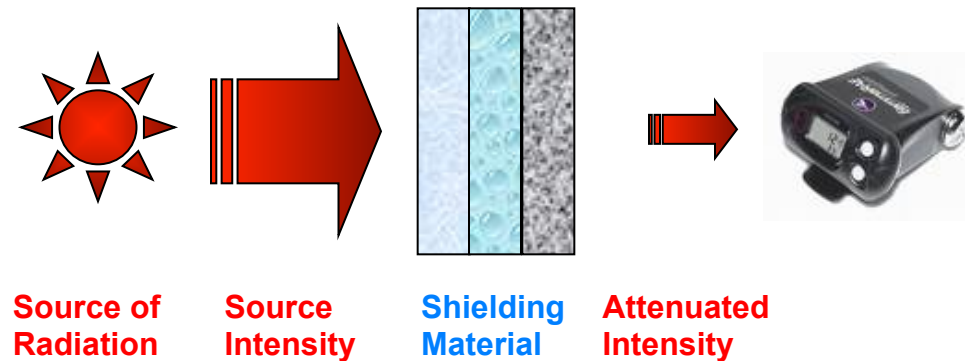

Typical radiation shielding materials

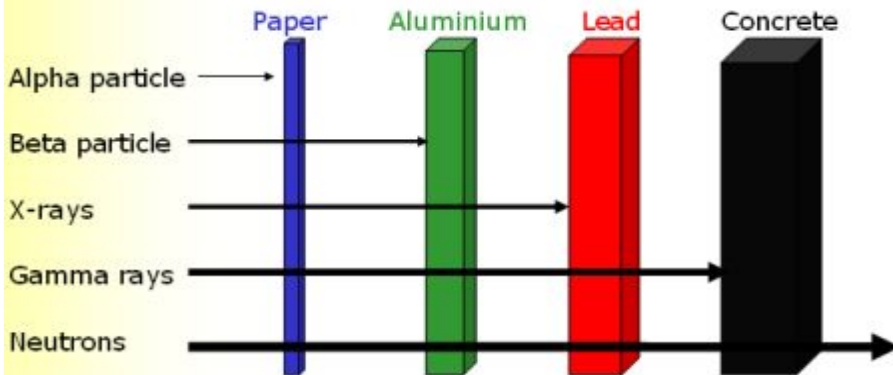

Interaction properties of radiation.

Radiation	Charge	Energy	Range in air	Range in H ₂ O
α particles	+2	3–10 MeV	2–10 cm	20–125 μ m
β^+ , β^- particles	± 1	0–3 MeV	0–10 m	<1 cm
Neutrons	0	0–10 MeV	0–100 m	0–1 m
X-rays	0	0.1–100 keV	m–10 m	mm–cm
Gamma rays	0	0.01–10 MeV	cm–100 m	mm–10s of cm

- ❑ The radiation **absorbed dose D** is the mean energy imparted to matter of mass M:
 $D = dE/dM$, unit gray, $1\text{Gy} = 1\text{J/kg}$ (=100 rads, old unit).
- ❑ The radiation **dose equivalent H** is the product of the absorbed dose D and the quality factor w_R (or Q) characterizing the damage associated with each type of radiation:
 $H = w_R \cdot D$, unit Sievert, $1\text{Sv} = 1\text{Gy} \cdot w_R$ (=100rem, old unit).
 - $w_R = Q = 1$ for X-rays, γ -rays, electrons
 - $w_R = Q = 20$ for α
 - $w_R = Q$ [2,10] for neutrons
- ❑ The **effective dose ϵ** is the equivalent dose H_T in organ or tissue T multiplied with a weight factor w_T describing the sensitivity of the tissue to radiation:

$$\epsilon = \sum w_T \cdot H_T = \sum w_T \sum w_R \cdot D_{T,R}$$
- ❑ **Radiation exposure T** is the absolute value of the ion charge produced in air per unit mass: $X = dQ/dM$, unit $1X = 1\text{C/kg}$ (old unit: 1 Roentgen, $1\text{R} = 2.58 \cdot 10^{-4} \text{C/kg}$).
- ❑ Usually **dose and exposure rates** (per s, min, h) are of most interest !

More Basic Terms

- ❑ **Stopping Power** is defined as the total loss of energy from a particle over a path length dx :

Linear Energy Transfer

$$S = \left(-\frac{dE}{dx} \right)_{col} + \left(-\frac{dE}{dx} \right)_{rad}$$

**Energy Loss
by Radiation**

- ❑ **Linear Energy Transfer (LET)** is defined as the energy imparted to the medium per path length:

- LET increases with MASS and CHARGE of the particle, e.g., LET of 1 MeV α in water is about 90 keV/ μm , but for a 1 MeV electron it is only ~ 0.19 keV/ μm .
- High LET radiation: α -particles, fission products, heavy ions.
- Low LET radiation: electrons, protons and positrons.
- Neutrons are **High LET** (produce heavy ions), photons are **Low LET** (produce e^-).

- ❑ **Specific ionization (SI)** is the number of ion pairs produced per unit path length:
 $SI = dN/dx$.

- ❑ **KERMA** (kinetic energy released in material) is the energy transferred to matter per mass, $K = dE_{kin}/dM$, unit 1Gy=1J/kg. (Easy to measure and compute.)

Attenuation and Range

Attenuation:

- A **reduction in intensity** of radiation with respect to distance traveled through a medium.

Range R_{particle} :

- In passing through matter, charged particles ionize and thus lose energy in many steps, **until their energy is (almost) zero**. The distance to this point is called the range of the particle.
- The range depends on:
 1. The type of particle,
 2. its initial energy and
 3. the material which it passes through.
- The mean range can be calculated by integrating the inverse of the stopping power over energy.

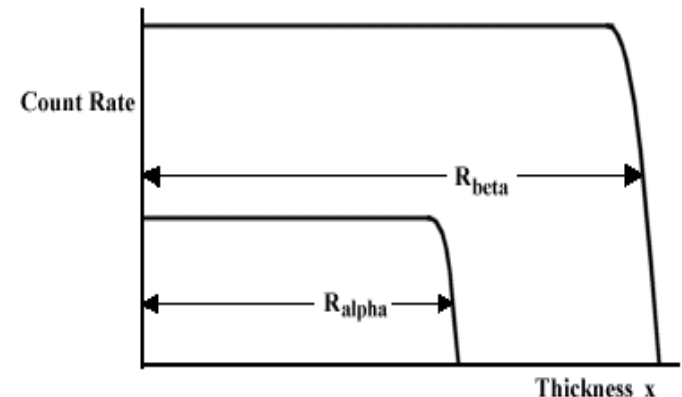
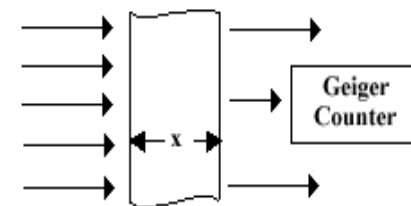
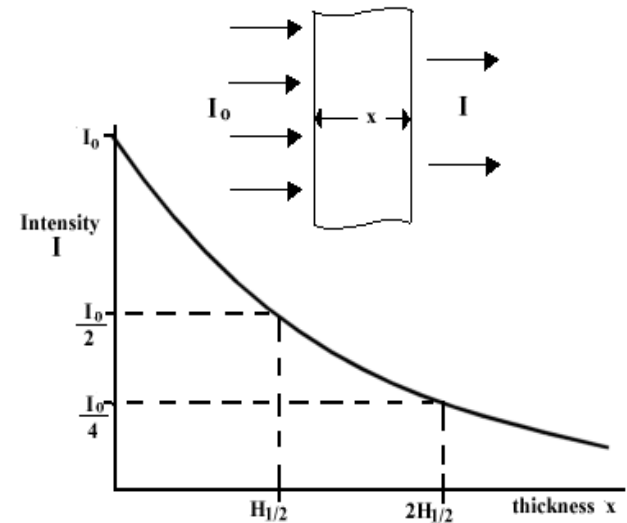

Interaction of Alpha (and Heavy Charged) Particles

- ❑ The specific ionization of alpha particles follows a **Bragg curve**.
- ❑ Alphas are **monoenergetic**.
 - Each particle has the same range R_α in the medium.
 - Straggling may occur.
- ❑ R_a in cm of standard air is empirically given by (E_α in MeV):

$$R_a = 0.325 E_\alpha^{3/2}$$

- ❑ Its range in another medium can be estimated by the Bragg-Kleeman rule:

$$R = R_a \left(\frac{\rho_a}{\rho} \right) \sqrt{\frac{M}{M_a}} = 3.2 \cdot 10^{-4} \frac{\sqrt{M}}{\rho} R_a$$

- ❑ For biological tissue R_t is approximately:

$$R_t \approx \frac{\rho_a}{\rho_t} R_a$$

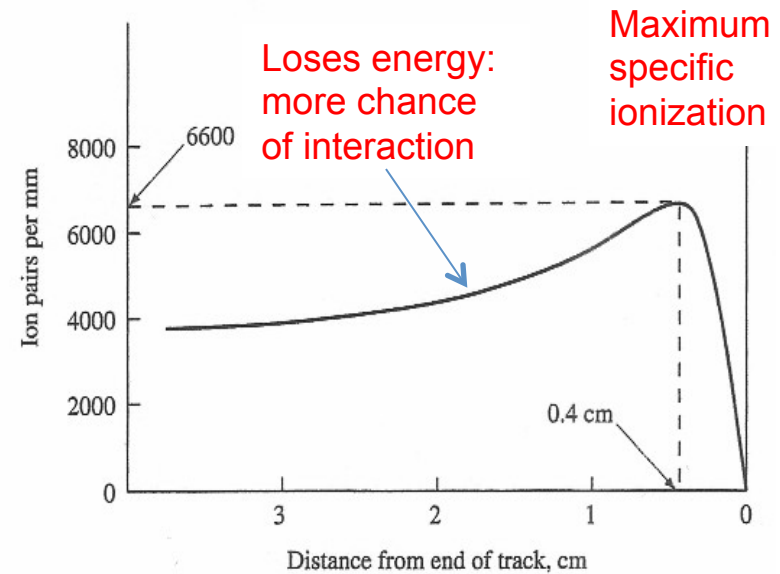

Specific ionization of an α -particle in air.

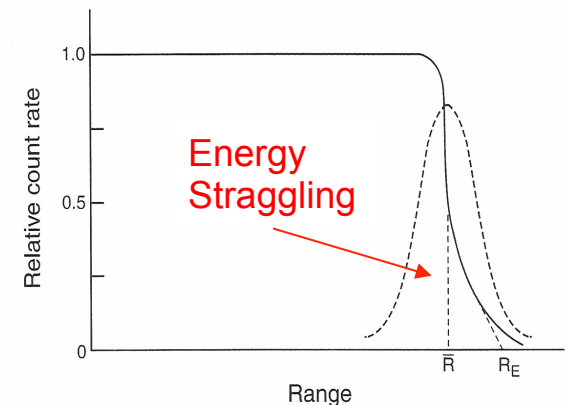

Range in air of a collimated monoenergetic source of alpha particles showing straggling that is normally distributed about the mean range at \bar{R} . An extrapolated range, R_E , can be obtained by extending the straight-line portion of the curve to the x-axis.

Shielding of Alpha (and Heavy Charged Particle) Sources

- ❑ Alpha particles are easy to shield due to their short and well predictable range.
- ❑ External radiation:
 - Absorbed by very **thin** layers of dense materials (range generally less than 1mm).
 - Stopped by dead skin layer.
- ❑ Internal Radiation:
 - Considerable damage to biological tissue: **Large ionization.**
 - High LET radiation.
- ❑ **Shielding avoids spread and contact by using fixatives on surfaces.**
- ❑ Very short range makes detection difficult:
 - Detector windows must be thin.
 - Highly contaminated areas may be missed by failing to get close enough.
- ❑ **Use proper detectors for alpha radiation!**
- ❑ Heavy charged particles have even shorter ranges!

Range almost linear

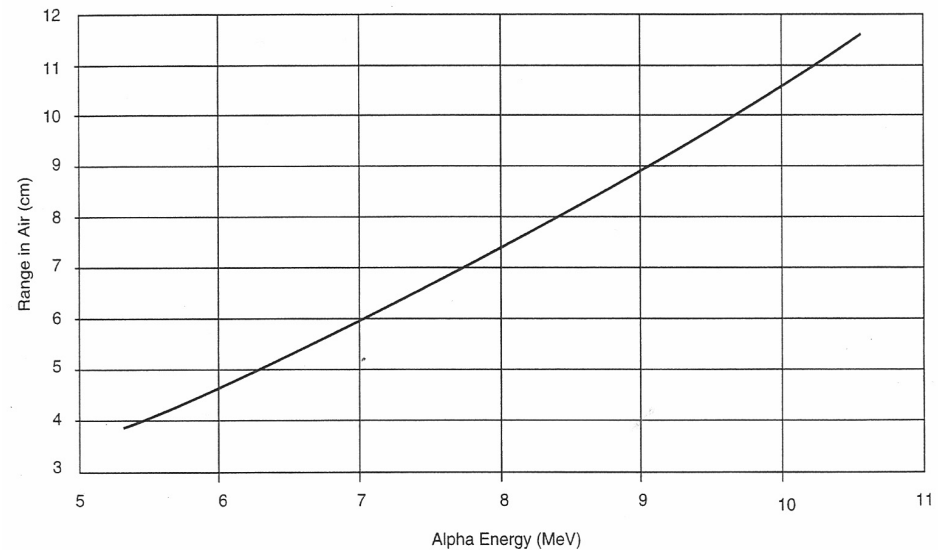

Range versus energy of alpha particles in air.

Interaction of Beta Particles with Matter

□ Beta particles lose energy to a medium in four ways:

- Direct ionization.
- “Delta” rays from electrons ejected by ionization.
- Bremsstrahlung.
- Cherenkov radiation.

□ Ionization:

- Eject K,L or M shell electrons: characteristic X-rays are produced.
- Beta particle paths are tortuous: low LET and stopping power.
- Secondary ionizations are produced by “delta”-rays.

□ Bremsstrahlung:

- Continuous energy spectrum.
- Important at high Z: up to 10% of 2 MeV β energy in Pb.
- In tissue less than 1% is Bremsstrahlung with low probability of interaction (low Z).

□ Cherenkov radiation is caused by high-speed beta particles in media if $(v/c) > (1/n)$, n =refractive index of the medium.

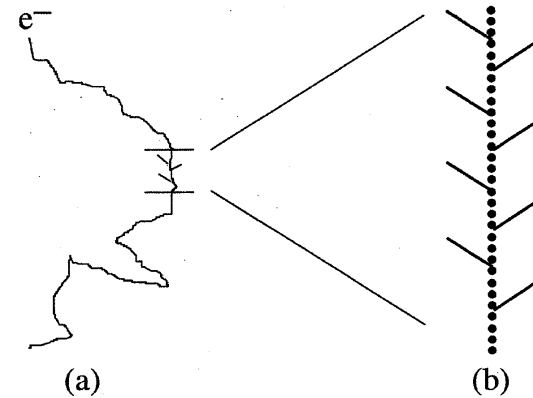

(a) Range and ionization path of a beta particle in an absorbing medium; (b) amplified segment of ionization track showing delta ray tracks produced by ejected electrons.

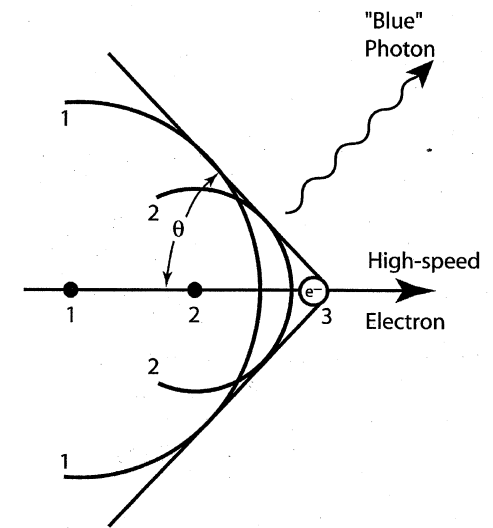

Wavefronts produced by a particle with velocity $\geq c/n$ constructively interfere to produce blue photons of light, or Cherenkov radiation.

Attenuation and Range of Beta Particles

- The attenuation of beta particles in a medium is exponential:
- The range of beta particles is short (few meters in air, tenths of mm in dense materials) and depends on their **kinetic energy** and **Z** of the material.

$$I(x) = I_0 e^{-\mu_{\beta,i}(\rho x)}$$

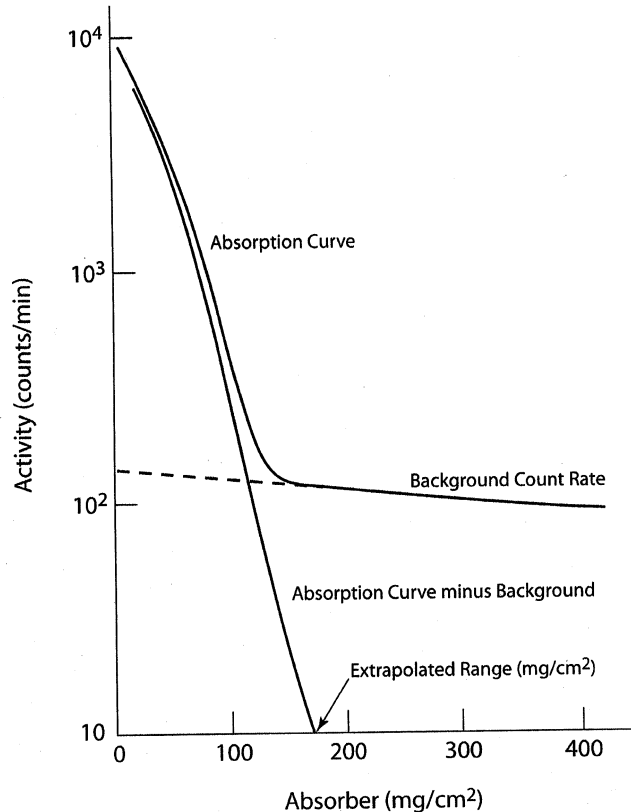

Decrease in measured activity of a beta particle source versus mg/cm^2 of absorber thickness that trails off into the background of the detector system. Subtraction of the background portion from the total curve yields a curve that can be extrapolated to estimate the maximum range (in mg/cm^2) of the beta source.

MAXIMUM RANGE OF BETA PARTICLES
as a Function of Energy in Various Materials

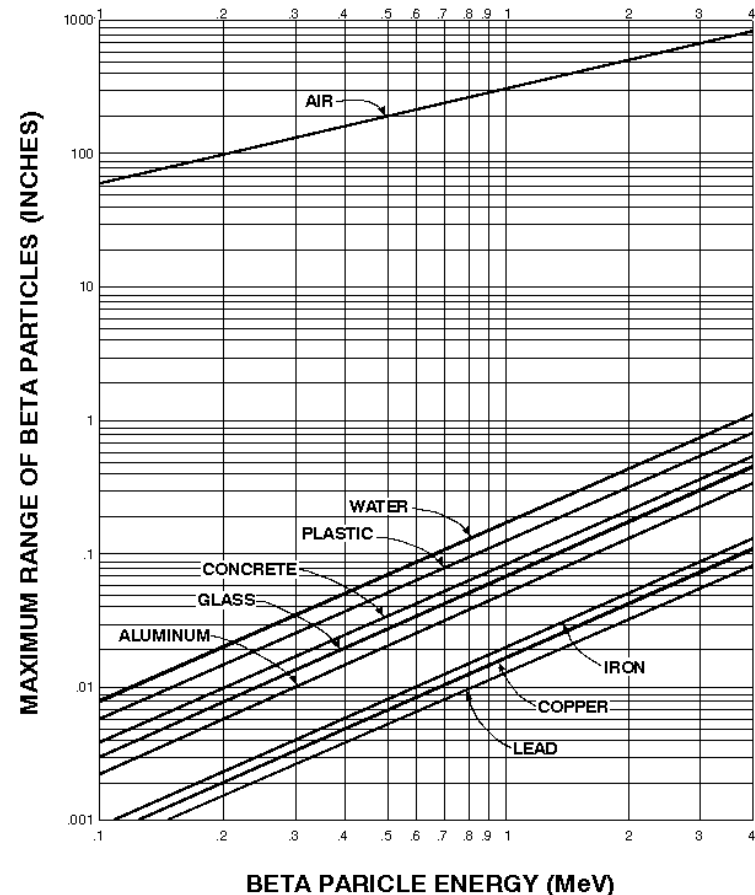

Shielding of Beta Sources

□ The intensity of a beta source is: $I(x) = I_0 e^{-\mu_{\beta,i}(\rho x)}$

- Approximations for the mass attenuation coeff. $m_{\beta,i}$ (in units of cm^2/g) in some media as a function of the **maximum** β -particle energy $E_{\beta,\text{max}}$ (in units of MeV) are given by:

$$\mu_{\beta,air} = 16(E_{\beta,\text{max}} - 0.036)^{-1.4}$$

$$\mu_{\beta,tissue} = 18.6(E_{\beta,\text{max}} - 0.036)^{-1.37}$$

$$\mu_{\beta,solid} = 17(E_{\beta,\text{max}})^{-1.14}$$

- ρx is the density thickness (g/cm^2) of the absorber.
- **All attenuating materials** between the source and the receptor must be considered, as well as **geometric configuration** and **backscatter**.
- External exposure: Shields are chosen a bit thicker than maximum range of most energetic β .
- Internal exposure: Prevent ingestion of β emitters and control surfaces with appropriate detectors (**smear tests**).

- ❑ Backscatter may occur for all sorts of radiation, however with different intensities.
- ❑ Backscattering most efficient for identical scattering partners or partners with similar mass:
 - **β -radiation is backscattered with intensity $\sim Z$**
 - **neutrons are effectively backscattered by Hydrogen**
- ❑ Backscattering depends also on the geometry (incident angle on surface) and the energy of the radiation beam.
- ❑ The backscattering material should not transmit radiation, i.e. must have saturation thickness.

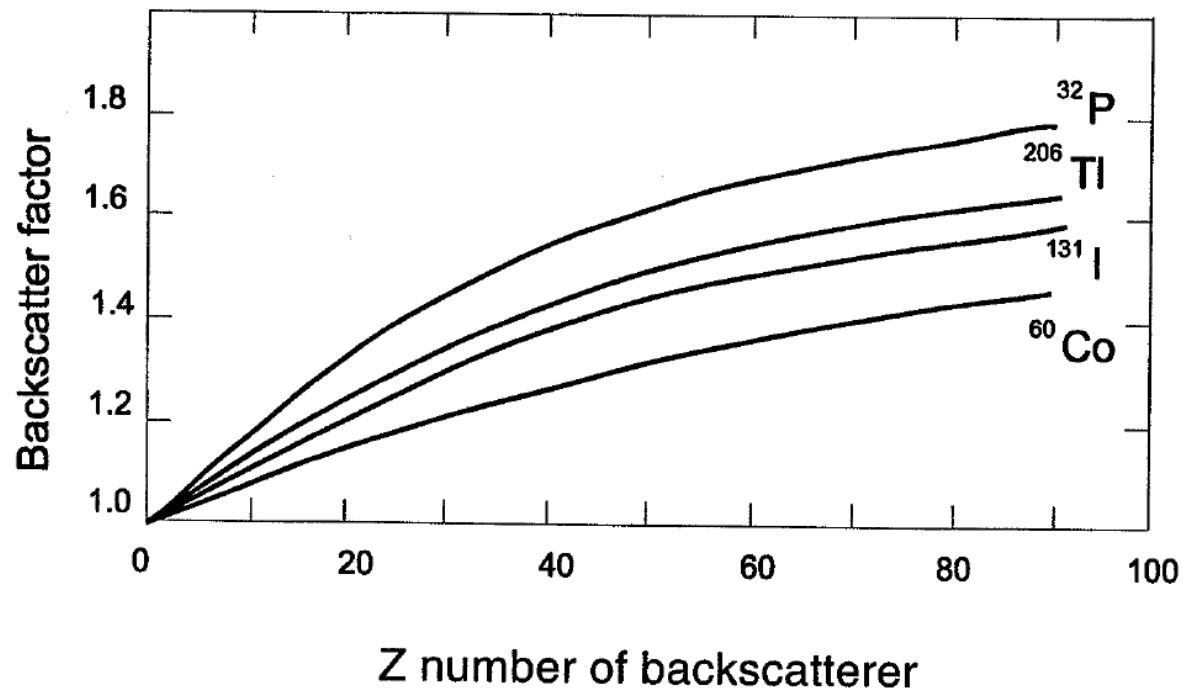

Backscatter factors (relative values), for β particles emitted from ^{32}P (695 keV), ^{206}Tl (540 keV), ^{131}I (182 keV), ^{60}Co (96 keV), as functions of the Z number of the backscatterer. The energies are the averages of each particle spectrum (based on Shapiro, 1972, Figure 4.4).

Shielding of Beta Sources with Bremsstrahlung

- ❑ Important for high Z materials.
- ❑ Shield design must account for the fraction Y_i of total energy transformed into photons by Bremsstrahlung.
- ❑ Empirical formulas and tables are based on **monoenergetic** e^- .
- ❑ For β sources it is difficult to compute accurate bremsstrahlung yields Y_i :
 - Continuous energy spectra.
 - Average β -energy is $\sim 1/3 E_{\beta,max}$.
 - Empirical relations were developed for Y_i .
 - Adjustment: multiply Y_i calculated for monoenergetic $E=E_{max}$ on an absorber by a factor of 0.3
- ❑ High Z materials (Pb) **should not** be used for high activity sources (^{32}P , $^{90}\text{Sr-Y}$)
 - Stop β with low Z element (plastic, Al).
 - Use high Z to trap any Bremsstrahlung γ .

Percent Radiation Yield for Electrons of Initial Energy E on Different Absorbers

E (MeV)	Absorber (Z)					
	Water	Air	Al (13)	Cu (29)	Sn (50)	Pb (82)
0.100	0.058	0.066	0.135	0.355	0.658	1.162
0.200	0.098	0.111	0.223	0.595	1.147	2.118
0.300	0.133	0.150	0.298	0.795	1.548	2.917
0.400	0.166	0.187	0.368	0.974	1.900	3.614
0.500	0.198	0.223	0.435	1.143	2.224	4.241
0.600	0.229	0.258	0.501	1.307	2.530	4.820
0.700	0.261	0.293	0.566	1.467	2.825	5.363
0.800	0.293	0.328	0.632	1.625	3.111	5.877
0.900	0.325	0.364	0.698	1.782	3.391	6.369
1.000	0.358	0.400	0.764	1.938	3.666	6.842
1.250	0.442	0.491	0.931	2.328	4.340	7.960
1.500	0.528	0.584	1.101	2.720	4.998	9.009
1.750	0.617	0.678	1.274	3.113	5.646	10.010
2.000	0.709	0.775	1.449	3.509	6.284	10.960
2.500	0.897	0.972	1.808	4.302	7.534	12.770
3.000	1.092	1.173	2.173	5.095	8.750	14.470

$$Y_i = \frac{6 \cdot 10^{-4} E_{\beta,max} Z}{1 + 6 \cdot 10^{-4} E_{\beta,max} Z}$$

Interaction of Photons with Matter

- Photons have no rest mass and behave like particles and waves (**duality**):

$$\left. \begin{array}{l} E = h\nu \\ p = h / \lambda \end{array} \right\} E = pc$$

- Photons lose energy interacting with matter **mainly** by:

- Photoelectric effect (low energy < 0.5 MeV), $\sigma_{pe} \sim Z^n/E^3$ (n=4-5)
- Compton Scattering (medium energy 0.5-1.0 MeV), $\sigma_c \sim Z/E$
- Pair Production (high energy > 1.022 MeV), $\sigma_{pp} \sim Z^2 \cdot (E-1.022)$
- Also Rayleigh scattering, Bragg scattering (diffraction), photodisintegration.

- Attenuation coeff.: $\mu_{tot} = \mu_{pe} + \mu_C + \mu_{pp}$

- Linear attenuation coefficient: $\mu = N \cdot \sigma$
- Mass attenuation coefficient: $\mu_m = \mu/\rho$

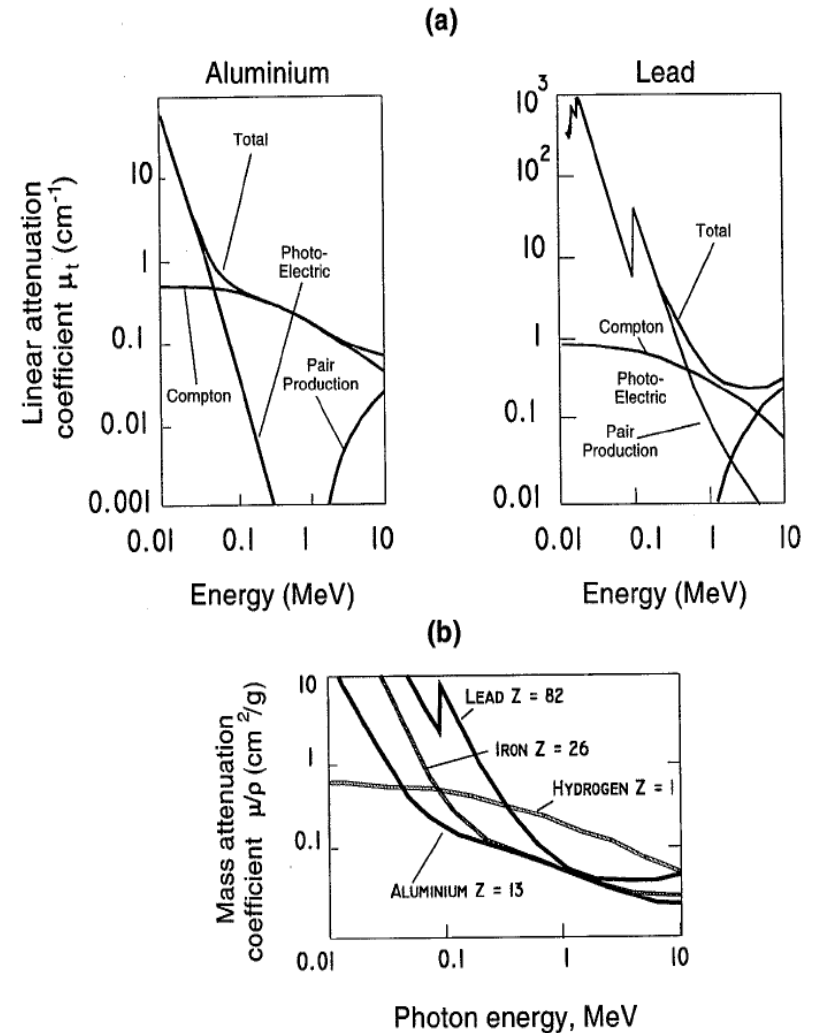

Total linear and mass attenuation coefficients (μ_t cm⁻¹ and μ_m cm²/g) for γ rays. (a) μ_t values for aluminium ($Z=13$, $\rho=2.70$ g/cm³) and lead ($Z=82$, $\rho=11.3$ g/cm³), showing the three mutually independent components. (b) The mass attenuation coefficient μ_m for the elements H, Al, Fe and Pb. Note the different function for hydrogen.

□ “Good” and “Bad” geometry:

- **“Good” geometry (narrow-beam)**: Only non-scattered (primary) photons (that have the same energy as the original beam) reach the receptor.
- **“Bad” (broad-beam) geometry**: Also scattered (secondary) photons of lower energy can reach the receptor and lead to a complex energy spectrum.
- Shield design must tend to “good” geometry.

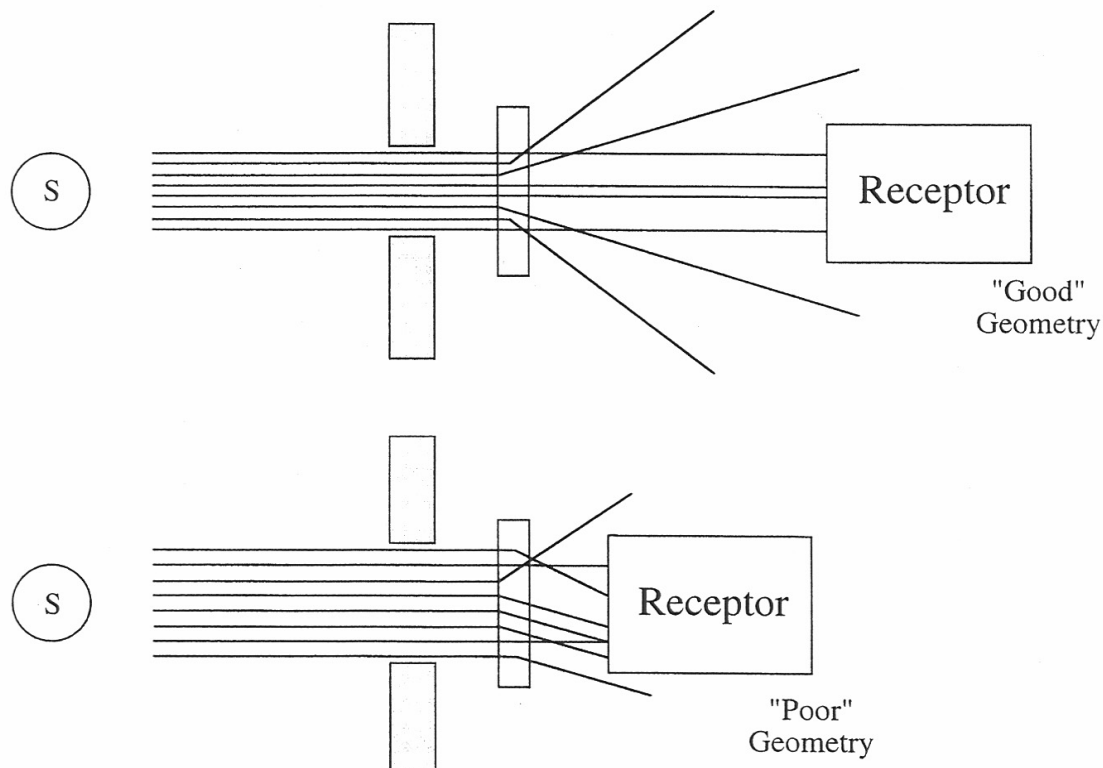

- ❑ The attenuation obeys an exponential law:
- ❑ The attenuation coefficient μ (cm^{-1}) is the sum for **all interactions**:
 - Depends on photon energy and Z of the absorber medium:
 - => Pb is often used as shield for X-rays.
 - BaSO_4 is incorporated into concrete.
 - μ grows with Z because of rising importance of photoelectric effect and pair production.
- ❑ Tables for μ and μ/ρ in various materials exist.
- ❑ Half-and Tenth-Value Layers:
 - HVL: Intensity decreased by half
 - TVL: Intensity decreased by ten.
 - Used for fast estimations of dose and shielding.

Attenuation of Photons

$$I(x) = I_0 e^{-\mu x}$$

Half-Value Layer (HVL)

$$\frac{I(x_{1/2})}{I_0} = \frac{1}{2} = e^{-\mu x_{1/2}}$$

$$x_{1/2} = \text{HVL} = \frac{\ln 2}{\mu}$$

Tenth-Value Layer (TVL)

$$x_{1/10} = \text{TVL} = \frac{\ln 10}{\mu}$$

Shielding of Photons with Scattering (1)

- ❑ Most common situations in photon shielding have photon scattering.
- ❑ Thick shields produce large amount of **lower-energy scattered photons** from Compton effect.
- ❑ The flux of photons reaching the receptor is a function of:
 - Beam size.
 - Photon energy distribution.
 - Absorber material.
 - Geometry.
- ❑ $I(x)$ based only on μ underestimates the flux reaching the receptor.

Shield design MUST account for scattered photons.

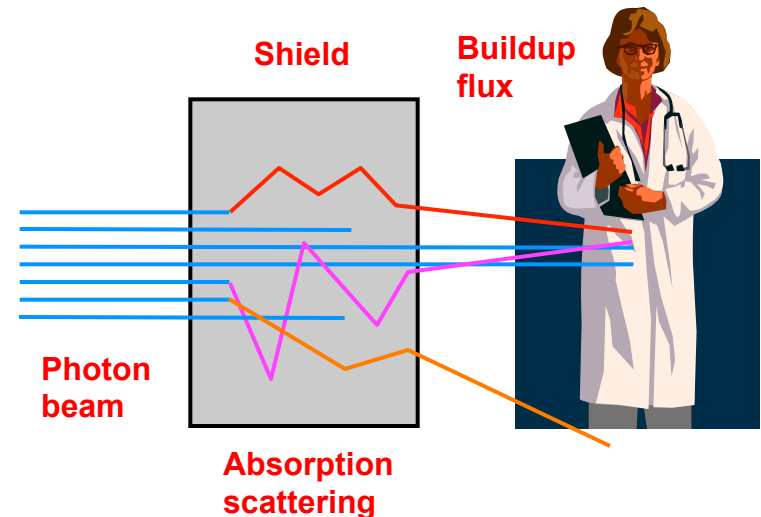
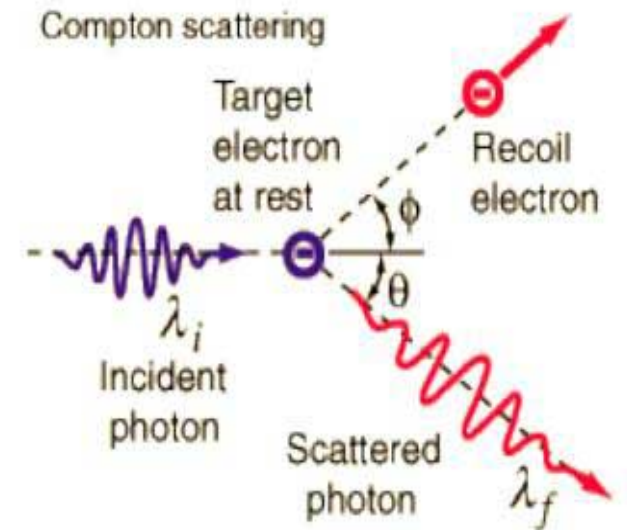

Shielding of Photons with Scattering (2)

- ❑ The effect of scattered photons is accounted for by using a buildup factor $B > 1$.
- ❑ The radiation intensity with buildup is:

$$I(x) = I_0 B(E, \mu x) e^{-\mu x}$$

- ❑ Buildup factors are determined experimentally and tabulated for point sources.

- ❑ B depends on:

- The absorbing medium Z .
- The photon energy E .
- The attenuation coefficient μ .
- The absorber thickness x .

- ❑ Mathematical approximations for B have been developed from fits to the experimental data for particular absorbers and E_{photon} .

Mathematical Formulations:

Taylor Form (*caution for low energy and Z*)

$$B(E, \mu x) = A e^{-\alpha_1 \mu x} + (1 - A) e^{-\alpha_2 \mu x}$$

Single Term Taylor Form, precise for ($3 < \mu x < 8$)

$$B(E, \mu x) \approx A_1 e^{-\alpha_x \mu x}$$

Linear Form (*generally acceptable results*)

$$B(E, \mu x) = 1 + \alpha_l (\mu x)$$

- Many shielding calculations are easy once the flux is known.
- For a **point source**, the flux at a location r attenuated by an absorber μx is given by:

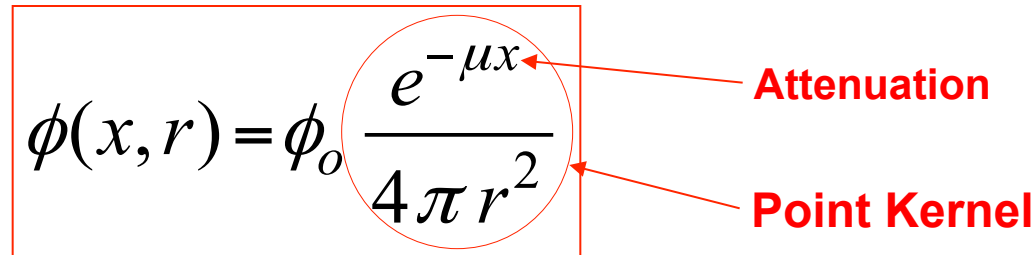
$$\phi(x, r) = \phi_o \frac{e^{-\mu x}}{4\pi r^2}$$

Attenuation

Point Kernel

- The Point Kernel is used to develop relationships between flux and exposure for various source geometries and absorbing media.
- Real-world exposure conditions have varied geometrical shapes, but the total flux can be determined assuming point kernels spread over the geometries.

Shielding of a linear source:

- Annular ring around the linear source.
- Sheet of metal close to a pipe.

Need to account for:

- Scattering (buildup factor B).
- Assume all photons penetrate the shield perpendicular to surface (overestimate).

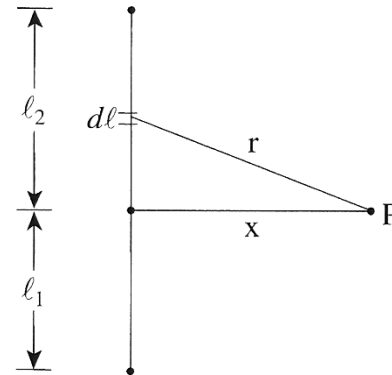

(a)

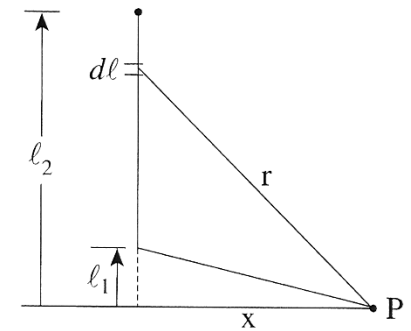

(b)

Schematic of a line source of radioactive material that emits S_L gamma rays per centimeter over a finite length (l_1 to l_2) or is infinitely long ($l = \infty$) to produce a flux at P with (a) coordinates along the line, or (b) some distance from one end of the line source.

$$d\phi_l = \frac{S_L}{4\pi r^2} dl$$

$$r^2 = l^2 + x^2$$

$$\phi_{l,\infty} = \int_{-\infty}^{\infty} \frac{S_L}{4\pi(l^2 + x^2)} dl \longrightarrow \phi_P = \phi_{l,\infty} (\gamma/\text{cm}^2 \times s) = \frac{S_L}{4x}$$

$$\phi_l = \int_{l_1}^{l_2} \frac{S_L}{4\pi(l^2 + x^2)} dl \longrightarrow \frac{S_L}{4\pi x} \left(\tan^{-1} \frac{l_2}{x} + \tan^{-1} \frac{l_1}{x} \right) \quad (a)$$

$$\longrightarrow \frac{S_L}{4\pi x} \left(\tan^{-1} \frac{l_2}{x} - \tan^{-1} \frac{l_1}{x} \right) \quad (b)$$

Examples of planar Sources:

- Spill areas on floors.
- Contaminated surfaces.

Assumptions:

- Isotropic Source S_A ($\gamma/\text{cm}^2 \cdot \text{s}$)

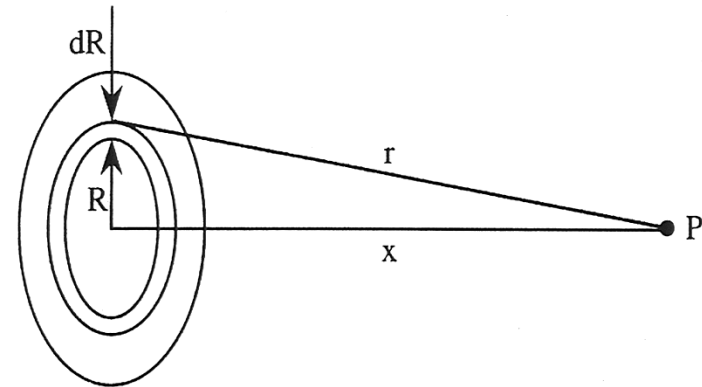

A disc source with a uniform emission rate of S_A photons per unit area produces a differential flux at point P a distance r from a thin ring of width dR and area $2\pi R dR$

$$d\phi = S_A \frac{2\pi R dR}{4\pi r^2}$$

$$r^2 = x^2 + R^2$$

$$\phi_P = \frac{S_A}{2} \int_0^R \frac{R dR}{r^2}$$

$$\phi_u(P)_A = \frac{S_A}{4} \ln \left(1 + \frac{R^2}{x^2} \right)$$

$$\phi_u(P)_A = \frac{S_A}{2} \ln \frac{R}{x}, \quad R \gg x$$

- ❑ Examples are large drums or tanks of radioactive materials.
- ❑ Complex accurate calculations:
 - Self-absorption.
 - Different materials.
 - Scattering.
- ❑ Approximate solutions can be calculated by dividing them up into several point-sources.
 - Tend to overestimate exposure.
 - Errors not large.
 - Detailed integration over many differential volumes is more precise (computer calculations).
- ❑ Volumetric sources are best analyzed by using Monte Carlo or deterministic transport codes.

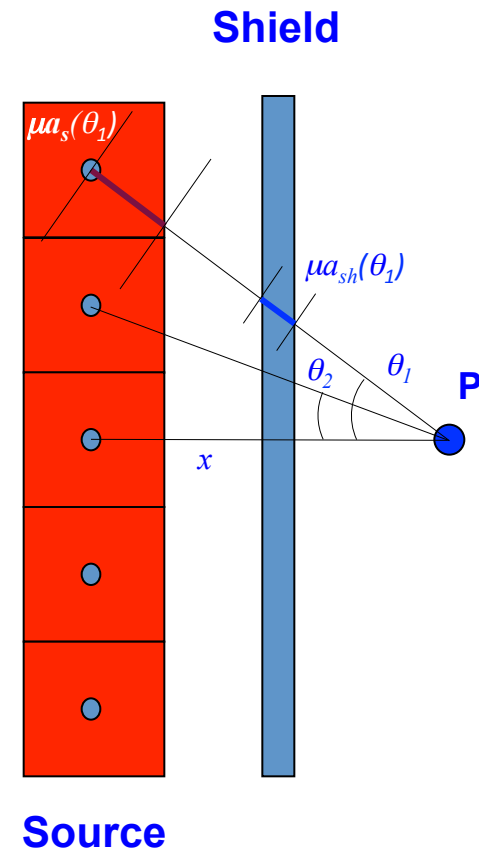

□ When combining absorbers attention must be paid to:

- Compton Scattering: high for low/medium γ -energy and low Z .
- Photoelectric absorption: low for low Z , high for high Z .
- They influence the combined buildup factor.

□ General Principles:

• Configuration:

- Low Z material (H_2O) produces higher fraction of scattered photons.
- High Z material (Pb) absorbs more scattered photons.
- Low Z closest to source, high Z will absorb scattered γ .

• Buildup factor:

- If $Z_2 - Z_1 < 10$ then $B_{Z_1+Z_2}$ is taken the largest of B_{Z_1} and B_{Z_2} for the combined thickness.
- If $Z_2 \gg Z_1$ (Low Z closest to source): B_{Z_2} because scatter from Z_1 will be absorbed.
- If $Z_1 \gg Z_2$ (High Z closest to source): $B_{Z_1+Z_2} = B_{Z_1}(\mu_1 a_1) \times B_{Z_2}(\mu_2 a_2) \quad E < 3 \text{ MeV}$
 $= B_{Z_1}(\mu_1 a_1) \times B_{Z_2}(\mu_2 a_2)_{3\text{MeV}} \quad E > 3 \text{ MeV}$

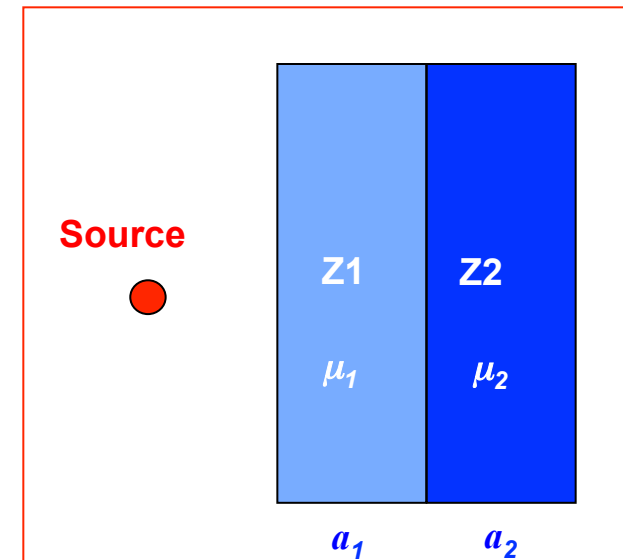

- ❑ Beams of protons, deuterons, tritons, and helium ions can be present around accelerators.
- ❑ These are charged particles of considerable mass and thus:
 - Ionize atoms in the shielding.
 - Stop completely in a short distance.
- ❑ The range is definite:
 - Attenuation due to ionization.
 - Range is a function of the most energetic particles in the beam.
- ❑ Design for shielding of light ions is based on the thickness of penetration R_p of a proton of a given energy.

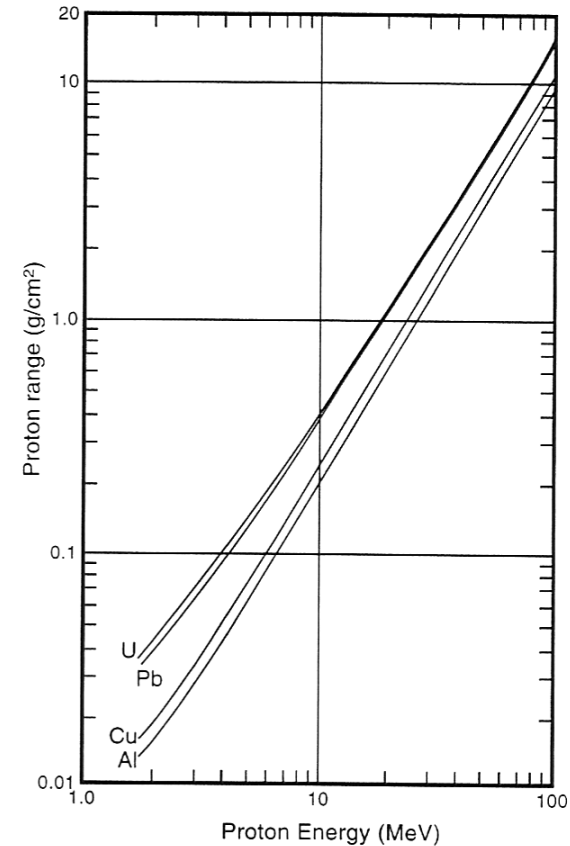

$$R(^2\text{H}^+) = 2 \times (R_p(E/2))$$

$$R(^3\text{H}^+) = 3 \times (R_p(E/3))$$

$$R(^4\text{He}^{2+}) = (R_p(E/4))$$

□ Neutrons (n) interact with matter (nuclei) in many ways:

- Elastic scattering: ${}^A_Z(n,n){}^A_Z$; energy loss of n is highest for light nuclei, thus n-moderation (slowing down) best with light scattering partners.
- Inelastic scattering: ${}^A_Z(n,n'){}^A_Z^*$
- Radiative capture: ${}^A_Z(n,\gamma){}^{A+1}_Z$
- Nuclear reactions: ${}^A_Z(n,p)$, ${}^A_Z(n,\alpha)$, ${}^A_Z(n,2n)$, ...
- Fission of heavy nuclei: ${}^A_Z(n,f)$

□ Neutron attenuation under “good” geometry conditions:

$$I(x) = I(0) \cdot \exp(-\Sigma_t \cdot x), \quad \Sigma_t = N \cdot \sigma_t = N \cdot (\sigma_e + \sigma_i + \sigma_\gamma + \sigma_r + \dots)$$

□ **Otherwise**, when the scattering of neutrons “back into the beam” plays a role, it must be taken into account (as for photons), by **buildup factors**, e.g., $B \sim 5.0$ for 20cm or more water or paraffin.

- The basis is to use materials that enhance the interactions that deplete neutrons:
 - Fast neutrons:
 - **First** moderation: elastic and inelastic scattering (γ -rays).
 - **Then** absorption of thermal neutrons.
 - Thermal neutrons:
 - Absorption: (n,γ) -reactions, but not $(n,2n)$, $(n,3n)$, (n,f) , ...

- Best moderating materials are those with:
 - Low Z: higher energy loss per collision, e.g., H_2 ($1/2E$ loss per interaction).
 - High elastic scattering X-sections.

- Best absorbing materials are those with large absorption cross sections for thermal neutrons: e.g., ^{10}B , Cd, H, Li, Gd, ...

☐ Hydrogenous materials (moderators)

- **Water**: (corrosion, leakage, contamination, etc.).
- **Paraffin**: (flammable). Shielding needed for the 2.225 MeV γ -photon from H neutron capture.
- **Polyethylene**: larger H/volume than water.
- **LiH**: no γ from neutron capture, but Tritium formation from ${}^6\text{Li}$.

☐ Elements used as shielding materials in NPP

- **Pb, Fe**: Capture γ -rays, ${}^{59}\text{Fe}$ activation.
- **W**: Better than Pb. Secondary γ -radiation from neutron capture.
- **U (depleted)**: best attenuator for γ -rays, low neutron capture γ , but high γ flux from fast fission reactions.
- **B**: incorporated in Boron based shields. High thermal absorption cross section.
- **Concrete and earth**: high H content; added B.
- **Cd**: large absorption X-section; high capture γ -photons (9.05 MeV).

☐ Monte Carlo Radiation Transport:

- Calculates the “history” of a particle traversing a medium by simulating the random nature of the particle interaction with the medium.
- Requires a complete mathematical description of the probability relationships that govern:
 - The path length between interaction points,
 - the choice of an interaction type at each such points,
 - the choice of a new energy and direction (if scattering occurs),
 - the possible production of additional particles.

☐ Stochastic Character:

- The process of selecting the values for the variables is based on the selection of random numbers.
- Results must be interpreted from a statistical point of view.
- Computationally expensive.

☐ Allows for very complicated 3D geometries.

Photon history in Monte Carlo method

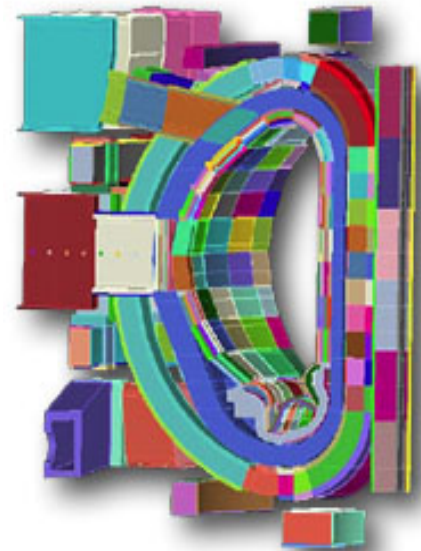
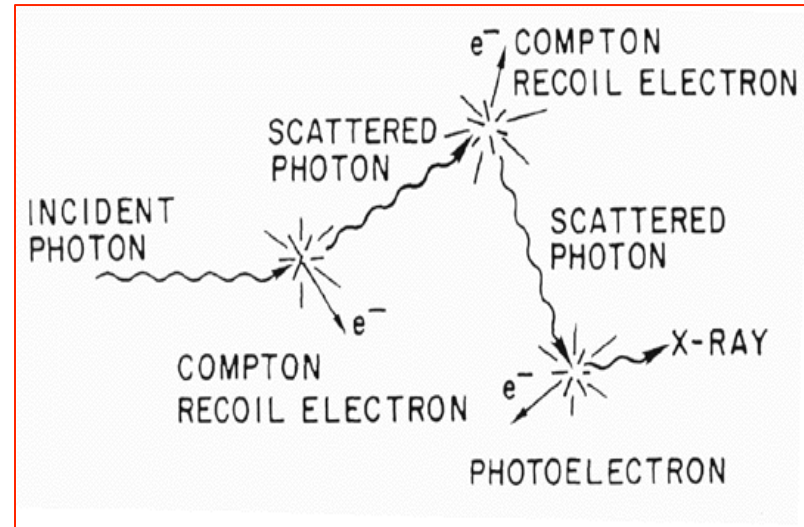

**MCNPX-CAD
Model for the
ITER**

- ❑ Radiation Shielding is a very complex discipline.
- ❑ It is a form of radiation protection:
 - Source Intensity.
 - Shielding Material.
 - Radiation Energy.
 - Geometry.
- ❑ Alpha particles and light ions can be shielded by a sealer (very short ranges in most media).
- ❑ Beta particle shield requires selection of material and thickness to stop highest energy beta and Bremsstrahlung (high energy, high Z). Strategy : **Low Z + High Z**
- ❑ Photon shields governed by exponential (probabilistic) attenuation.
 - Flux is a complex mixture of scattered and unscattered photons.
 - Need the use of buildup factors ($B > 1.0$) to account for scattering effects.
- ❑ Neutrons must be slowed down and then absorbed.
 - Shield is governed by exponential attenuation.
 - Also need to account for scattering back into the beam in low Z elements (water, paraffin): $B > 5$

- ❑ James E. Martin, “*Physics for Radiation Protection*”, Wiley-VCH (2nd edition, 2006)
- ❑ J. Kenneth Shultis and Richard E. Faw, “Radiation Shielding”, ANS Publication (2000)
- ❑ J.R. Lamarsh, A.J. Baratta, “Introduction to Nuclear Engineering”, Prentice Hall (3rd edition, 2001)