

Application Layer

Jean-Yves Le Boudec
2019



The Simpsons: Tapped Out
187,122 likes · 18,542 talking about this



Contents

1. The Application Layer
 2. QUIC
3. The Domain Name System
4. Application Layer Gateways
 5. IPv4 / IPv6
 6. ALG46

Textbook

Chapter 2: The Application Layer

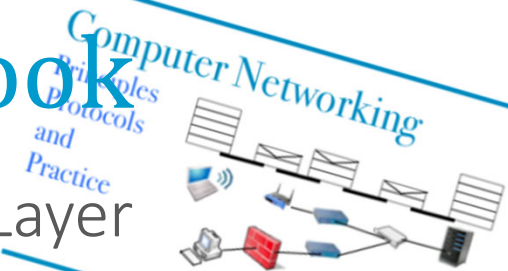

1. The Application Layer

The application layer of TCP/IP consists of
the distributed applications themselves – it is the topic of the
courses on information systems and distributed systems
a number of generic intermediate “layers”

You did several application layers in the socket programming lab

In this module, we focus on

the relationship between the application layer and the lower layers
the generic intermediate layers

Example: World Wide Web (WWW)

HTTP/1.1 uses one TCP connection per object

HTTP/2 allows to use the same TCP connection for several objects with parallel processing of requests (at the application layer).

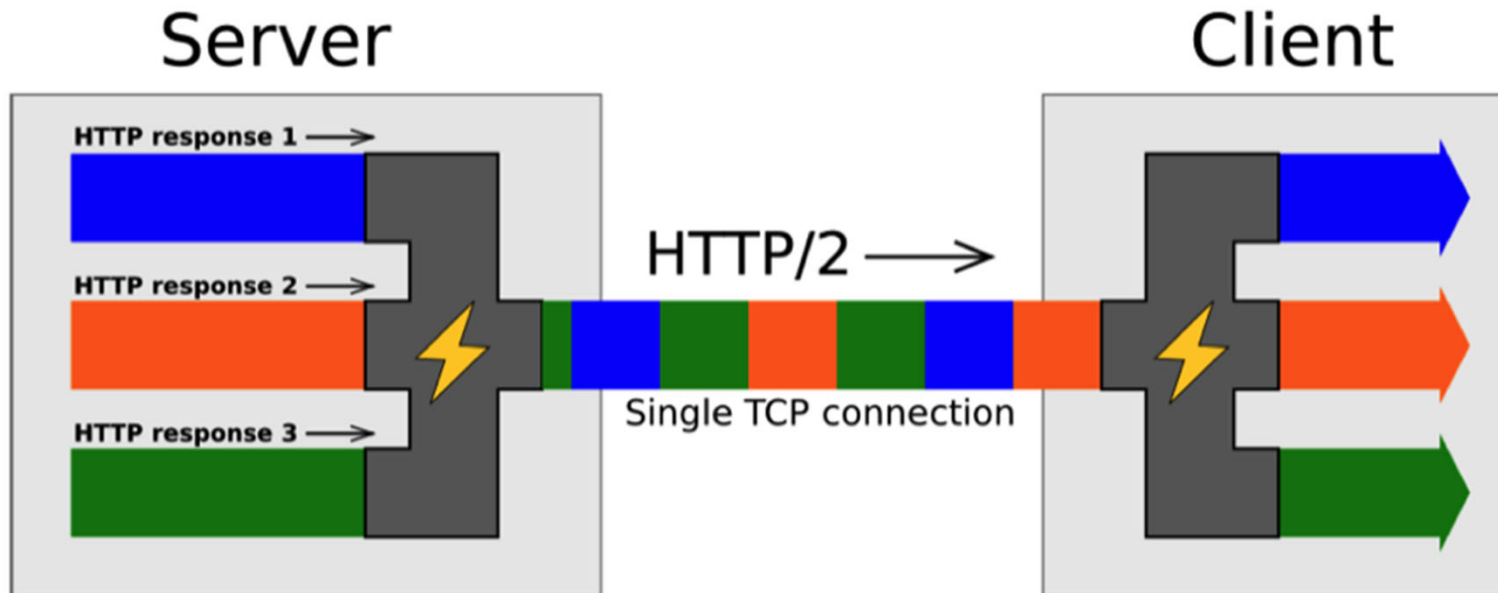

A server sends us a web page with 10 embedded objects (images, scripts, etc) using http/2 over one single TCP connection. Our browser displays the elements of the page as soon as they arrive, without waiting for the page to be complete.

One packet of the first object is lost (and will be retransmitted).

- A. The second object can be displayed before the lost packet is repaired because HTTP/2 multiplexes objects
- B. The second object must wait for the first object to be completely received
- C. It depends which version of TCP is used
- D. I don't know

Which of these port numbers are TCP server ports ?

- A. 20
- B. 21
- C. 12346
- D. 20 and 21
- E. 20 and 12346
- F. 21 and 12346
- G. all of these three
- H. none of these three
- I. I don't know

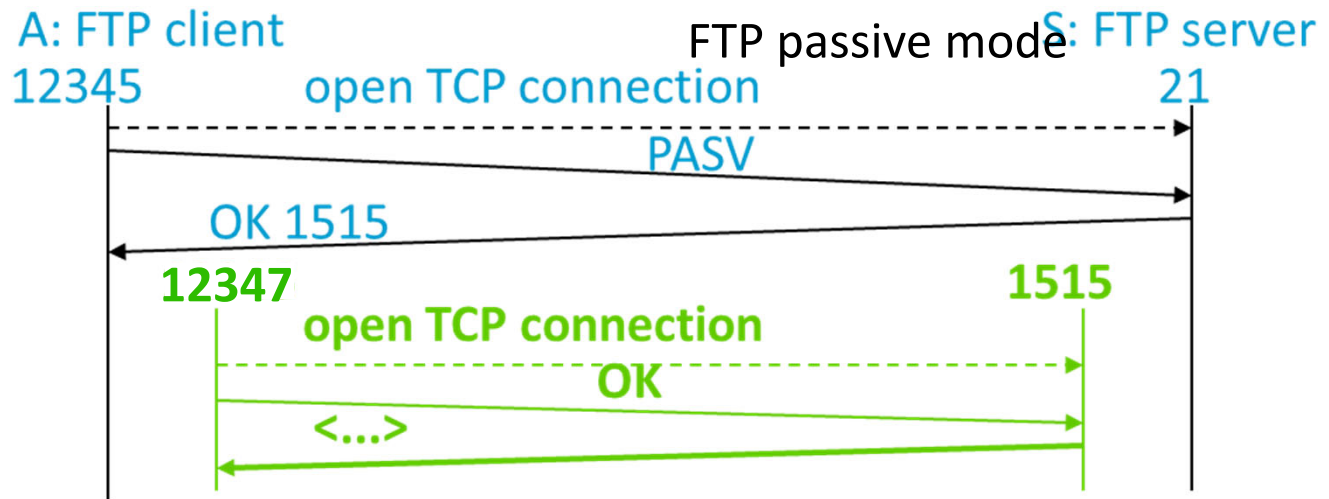
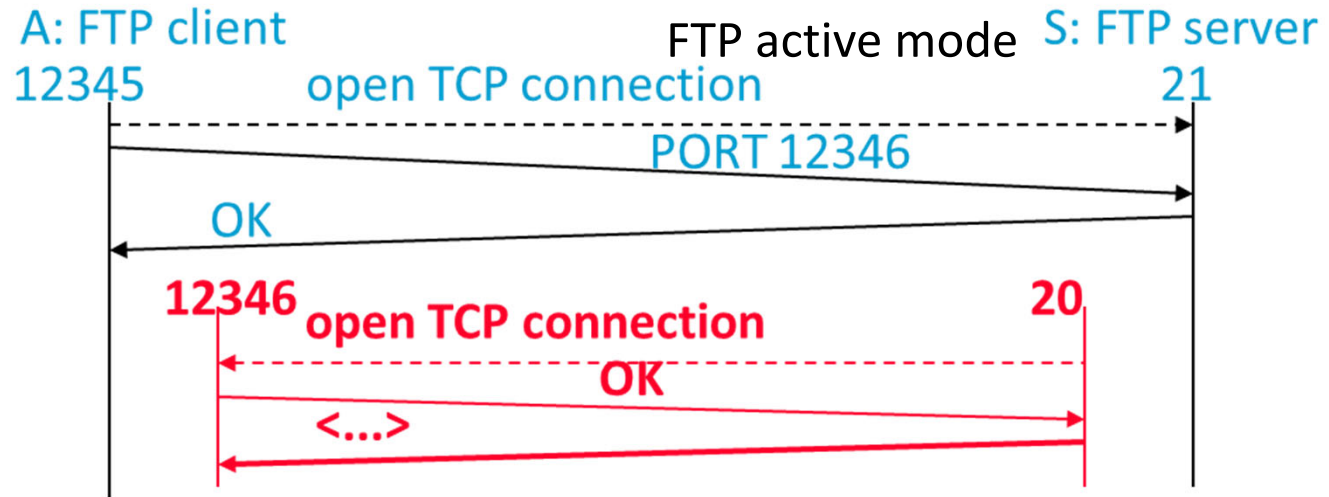

Solution

- Answer B

The objects are transferred over a single TCP connection; TCP offers a streaming service with in-sequence delivery. Object 2 cannot be delivered to the app before object 1 (even if all packets that contain object 2 are received). This is the head-of-the line blocking drawback of TCP

- Answer F

Port 20 used on the FTP server is not used in TCP server mode (the listen call is done on port 12346 on the FTP client side.

An (application) server is not always a (TCP) server !

2. QUIC

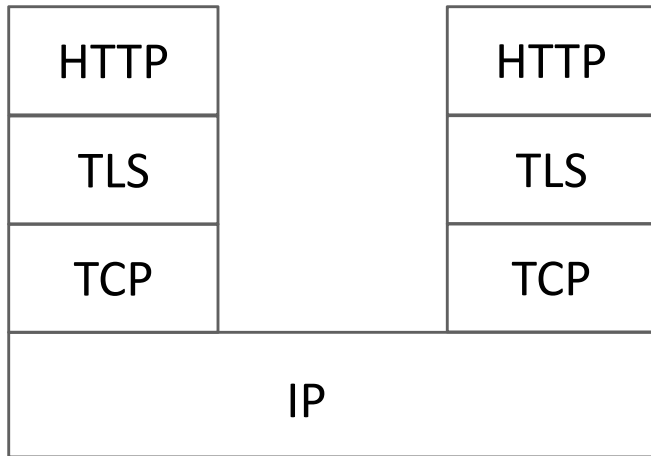

Recall that https means:

HTTP over
secure transport (TLS)

At least 2 RTTs before transmission of
user data can start

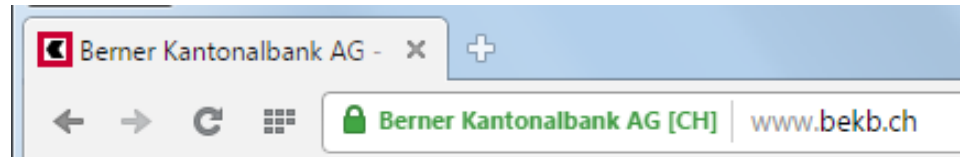

http used over TLS and port 443 = https

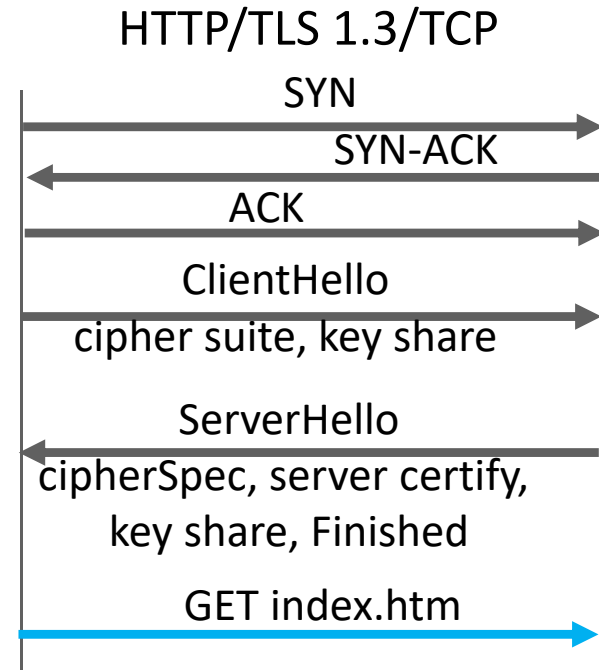

QUIC

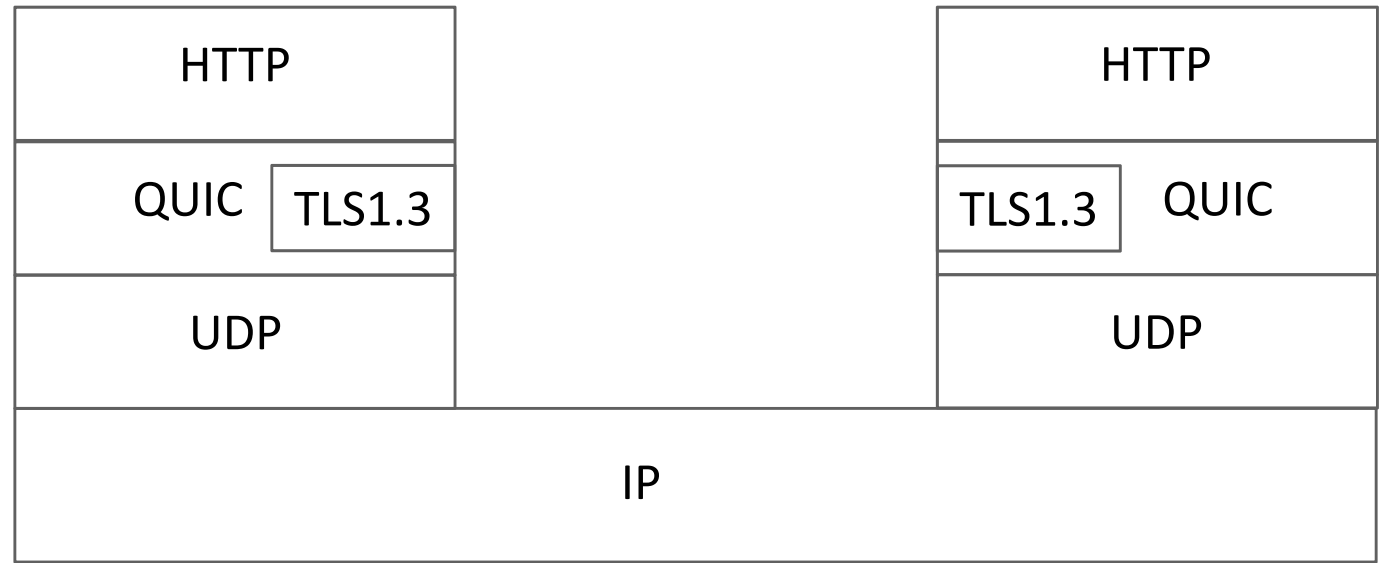

Why ? 1. Avoid latency and head-of-the line blocking of TLS over TCP
2. Modifications to TCP are often impractical because of filtering router that discard TCP options

How ? All in one !

QUIC opens one TLS 1.3 session first

QUIC runs over UDP

Data is always secured (with TLS 1.3 by default).

QUIC versus TCP with TLS1.3 (1-RTT case)

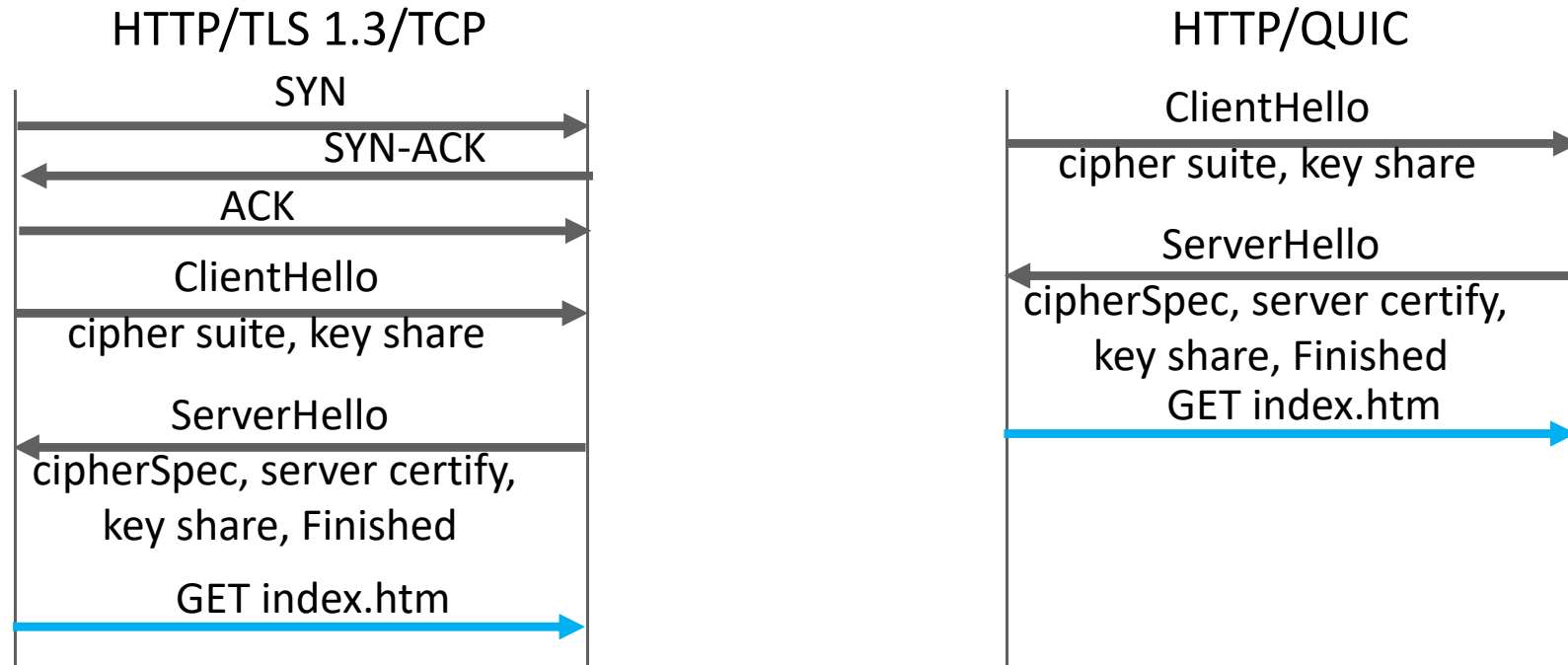

QUIC establishes a TLS1.3 session first.

QUIC assumes $MTU \geq 1280$ B.

Implemented in google apps (chrome, youtube app, etc.) where it replaces TCP (try it: [wireshark](https://wireshark.org/) or chrome://net-export/ and <https://netlog-viewer.appspot.com/>)

QUIC Packets, Streams and Frames

One QUIC session (also called “connection”) has multiples **streams**.

Stream can be reliable (like TCP) or not. For a **reliable stream**, data is delivered in sequence. For an **unreliable stream**, data may be delivered out-of-sequence (with indication of offset).

Streams can be created and deleted on-the-fly.

Stream 0 is for TLS1.3 and connection management.

One QUIC **packet** has a unique (increasing) packet number (64bits) – never wraps. A retransmitted packet has a different number.

A packet contains **frames** for stream data and other data.

QUIC hdr: Connection Id, Packet number		stream 0 crypto handshake data		ACK
stream 1 app data	stream 2 app data	stream 3 app data	stream 4 app data	MAX_STREAM_DATA

Reliable and Unreliable Streams

QUIC obtains **reliability similar to TCP**: missing packets are detected and retransmitted.

Packet loss detection incorporates the best known algorithms of TCP such as Fast Retransmit, RACK, Tail Loss Probe etc.

ACK frames contains up to 256 ack blocks (compare to TCP: 3 blocks).

Flow control is both per stream and per connection, using an explicit offset (instead of window).

Congestion control is similar to TCP Reno or Cubic, per connection (not per stream).

Unreliable streams do not have packet retransmission (in principle) but are subject to flow control and to congestion control.

Example: Ephemeral-QUIC

PMU streaming application sends one measurement in one packet every 20 msec. If one packet is lost but not recovered before 20msec, it is better to forget about it and use the newer measurement. With TCP we have head-of-the line blocking, a new measurement is delayed if previous one is lost.

Weiyu Zhang's solution with QUIC [Master thesis 2018]

- send one measurement in one reliable stream
- one stream per measurement
- kill stream if a new measurement is available and previous stream is not acknowledged

Lisa, behind a NAT, uses the youtube app. Will the app be able to use QUIC ?

- A. No because the NAT will not see TCP port numbers
- B. No because QUIC uses UDP and the UDP port numbers are encrypted
- C. Yes because QUIC uses UDP and the NAT can manipulate UDP port numbers
- D. I don't know

Solution

- Answer C
The NAT sees UDP packets with encrypted payloads.

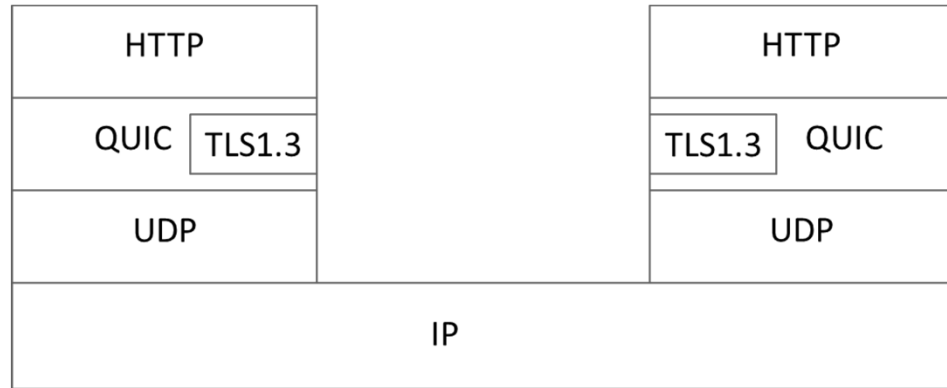

```
Wireshark - Paquet 71 - Ethernet 4
> Frame 71: 1392 bytes on wire (11136 bits), 1392 bytes captured (11136 bits) on interface 0
> Ethernet II, Src: Cisco_ff:fc:10 (00:08:e3:ff:fc:10), Dst: PacketFo_3c:35:26 (00:23:56:3c:35:26)
v Internet Protocol Version 6, Src: 2a00:1450:400a:803::200e, Dst: 2001:620:618:197:1:80b2:9771:1
  0110 .... = Version: 6
  > .... 0000 0000 .... = Traffic Class: 0x00 (DSCP: CS0, ECN: Not-ECT)
  .... .... 0000 0000 0000 0000 0000 = Flow Label: 0x00000
  Payload Length: 1338
  Next Header: UDP (17)
  Hop Limit: 57
  Source: 2a00:1450:400a:803::200e
  Destination: 2001:620:618:197:1:80b2:9771:1
v User Datagram Protocol, Src Port: 443, Dst Port: 52491
  Source Port: 443
  Destination Port: 52491
  Length: 1338
  Checksum: 0x11e7 [unverified]
  [Checksum Status: Unverified]
  [Stream index: 9]
  > [Timestamps]
0000 00 23 56 3c 35 26 00 08 e3 ff fc 10 86 dd 60 00  .#V<5&...
0010 00 00 05 3a 11 39 2a 00 14 50 40 0a 08 03 00 00  ...:~9*..P@....
0020 00 00 00 00 20 0e 20 01 06 20 06 18 01 97 00 01  ....
0030 80 b2 97 71 00 01 01 bb cd 0b 05 3a 11 e7 c3 51  ...q.....:...Q
0040 30 34 36 05 4d 23 7d 26 6f 22 89 7a 00 00 00 03  046~M#}& o"z....
0050 c2 e6 63 e2 32 cb 84 e2 18 e0 14 67 a4 01 0a 1c  ..c~2...g....
```

3.The Domain Name System (DNS)

Why invented ?

- ▶ support user friendly naming of resources: computers, printers, mailboxes,...
- ▶ hide IP address changes on servers

What does it do ?

- ▶ map DNS names (ex: ssc.epfl.ch) to IP addresses

DNS Names

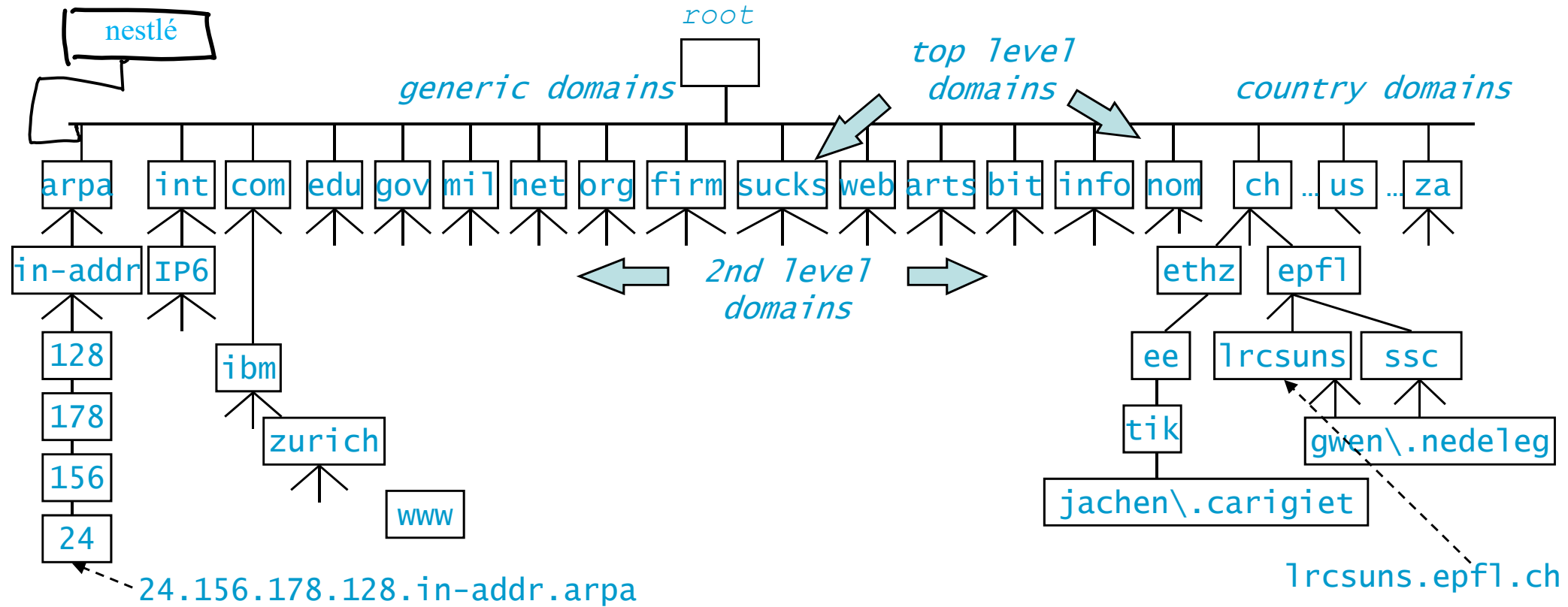

every node on the tree represents one or a set of resources

every node on the tree has a label `lrcsuns` and a domain name

`lrcsuns.epfl.ch`

label is made of 1 to 63 characters **a-z**, **0-9** or **-**

Other characters are allowed but real name is translated with *punycode*

Ex: `www.öpfl.ch` is in fact `www.xn--pfl-rna.ch`

How Does DNS Work ?

When Lisa's machine needs to map name to IP address

- ▶ DNS resolver in Lisa's machine contacts a DNS server
- ▶ IP address of DNS server is known to Lisa's machine at configuration time
- ▶ DNS server may not know answer: in such a case, DNS server needs to do several iterations, as shown on next example.
- ▶ A cache is used at DNS resolver and at DNS server to avoid repeating the same requests frequently.

DNS uses UDP for queries and responses (in principle)



Lisa clicks:

<http://www.zurich.ibm.com/RZ.html>

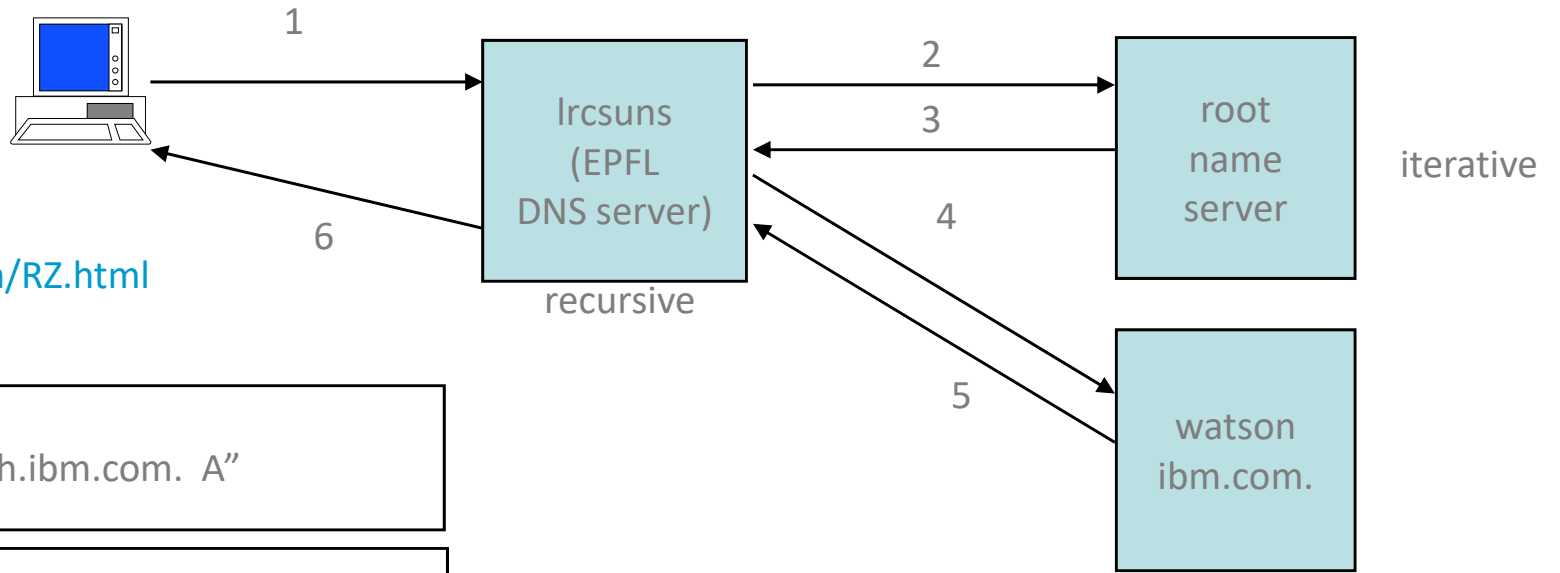

1 query, RD=yes
question = "www.zurich.ibm.com. A"

2,4 query, RD=no
question = "www.zurich.ibm.com. A"

3 answer
question = "www.zurich.ibm.com. A"
answer = ""
authority= "ibm.com. NS watson.ibm.com.
NS ns.austin.ibm.com.
NS ns.almaden.ibm.com."
additional="watson.ibm.com. A 192.35.232.34
ns.austin.ibm.com. A 129.34.139.4
ns.almaden.ibm.com A 198.4.83.134"

5,6 answer
question = "www.zurich.ibm.com. A"
answer = "www.zurich.ibm.com. 7200 A 193.5.61.131"

The previous slide shows an example of name resolution.

1. an application on lrcsuns requests a name resolution (find the IP address of www.zurich.ibm.com), a request is sent to the name server configured at lrcsuns
2. the epfl name server does not know the answer, but, as any name server, knows the IP address of root name servers.
3. a root name server knows the IP addresses of all name servers of all top level domains (such as .com, .info etc) and also of many level-2 domains. Thus, it informs lrcsuns of the IP address of the name servers responsible for the ibm.com domain
4. the epfl name server sends the same request now to the ibm name server
- 5 the ibm name server gives the IP address of www.zurich.ibm.com back to the epfl name server. The epfl name server keeps the address in its cache, this will be used if the same request comes again
- 6 the epfl name server gives the IP address of www.zurich.ibm.com back to lrcsuns. End of the resolution !

The request sent by lrcsuns is *recursive* (RD=yes): lrcsuns will receive only the final answer. In contrast, the request sent by the epfl name server is *iterative* (RD=no): it receives only partial answers that help towards the solution.

A (=IPv4) and AAAA (= IPv6) records

```
C:\Users\leboudec> dig a lca.epfl.ch
```

```
<<>> DiG 9.3.2 <<>> a lca.epfl.ch
```

```
;; global options: printcmd
```

```
;; Got answer:
```

```
;; ->>HEADER<<- opcode: QUERY, status: NOERROR, id: 652
```

```
;; flags: qr aa rd ra; QUERY: 1, ANSWER: 2, AUTHORITY: 0, ADDITIONAL: 0
```

```
;; QUESTION SECTION:
```

```
;lca.epfl.ch.                IN      A
```

```
;; ANSWER SECTION:
```

```
lca.epfl.ch.      86400    IN      CNAME   lca1srv2.epfl.ch.
```

```
lca1srv2.epfl.ch.86400    IN      A       128.178.156.24
```

```
C:\Users\leboudec> dig aaaa lca.epfl.ch
```

```
; <<>> DiG 9.3.2 <<>> aaaa lca.epfl.ch
```

```
;; global options: printcmd
```

```
;; Got answer:
```

```
;; ->>HEADER<<- opcode: QUERY, status: NOERROR, id: 415
```

```
;; flags: qr aa rd ra; QUERY: 1, ANSWER: 2, AUTHORITY: 0, ADDITIONAL: 0
```

```
;; QUESTION SECTION:
```

```
;lca.epfl.ch.                IN      AAAA
```

```
;; ANSWER SECTION:
```

```
lca.epfl.ch.      86400    IN      CNAME   lca1srv2.epfl.ch.
```

```
lca1srv2.epfl.ch.86400    IN      AAAA    2001:620:618:19c:1:80b2:9c18:1
```

A and AAAA records map name to IP address

CNAME record maps name to name

```
lca.epfl.ch.      86400   IN      CNAME   lca1srv2.epfl.ch.
```

here lca1srv2.epfl.ch is the canonical name

lca.epfl.ch is an alias

Caching and Time to Live

when receiving message 5, `stisun1.epf.ch` keeps answer from `watson.ibm.com` in a *cache* and does $TTL = 7200$ s for this cache entry. TTL decreases by 1 every second. When $TTL = 0$, cache entry is discarded by `lrcsuns`

During next 2 hours, further requests are answered directly by `lrcsuns`

`watson.ibm.com` is the “authoritative” DNS server for this record (i.e. the origin) -- decides value of *TTL* to be used by caching servers

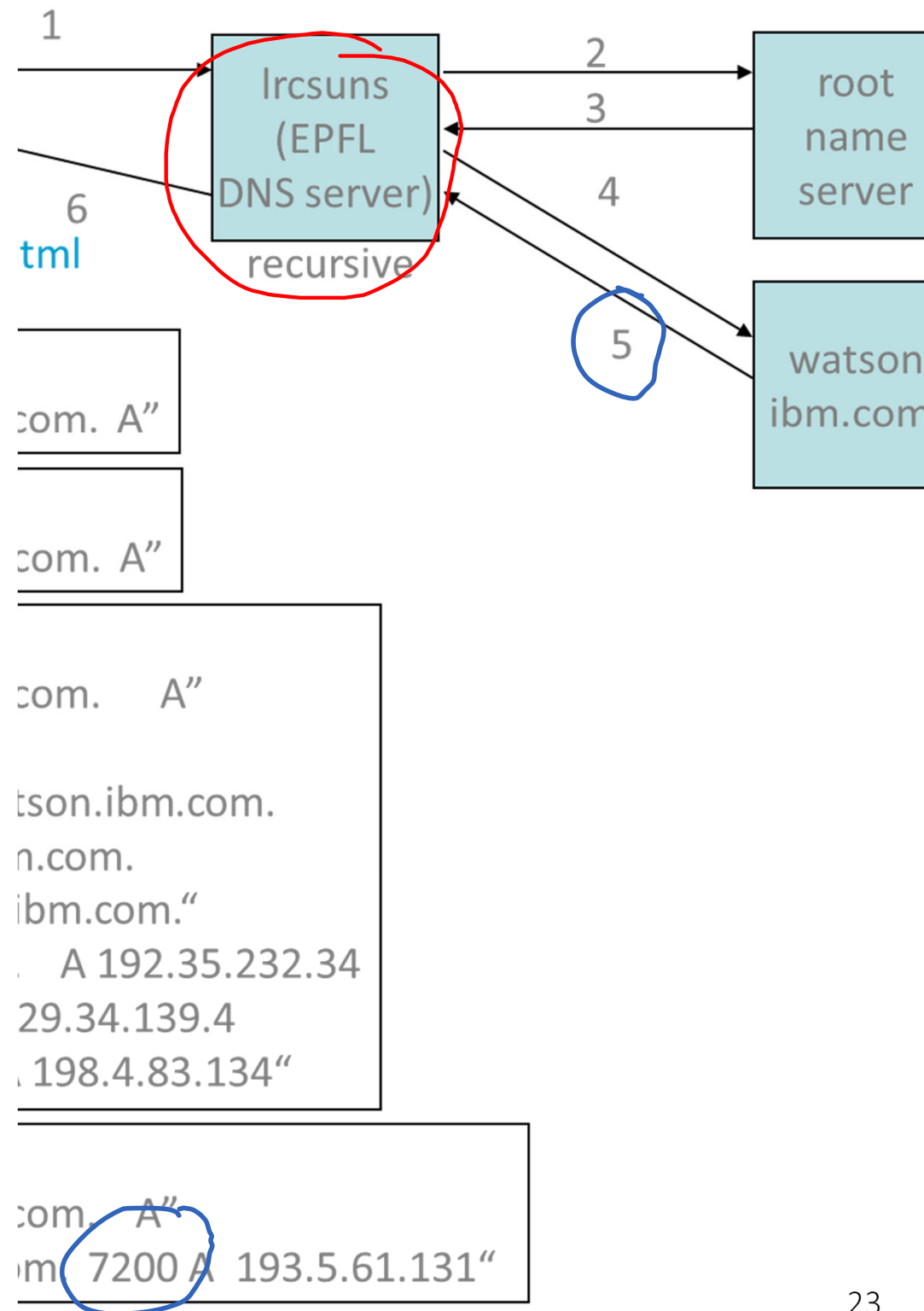

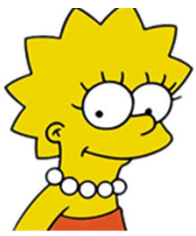

Lisa clicks:
<http://www.zurich.ibm.com/RZ.html>

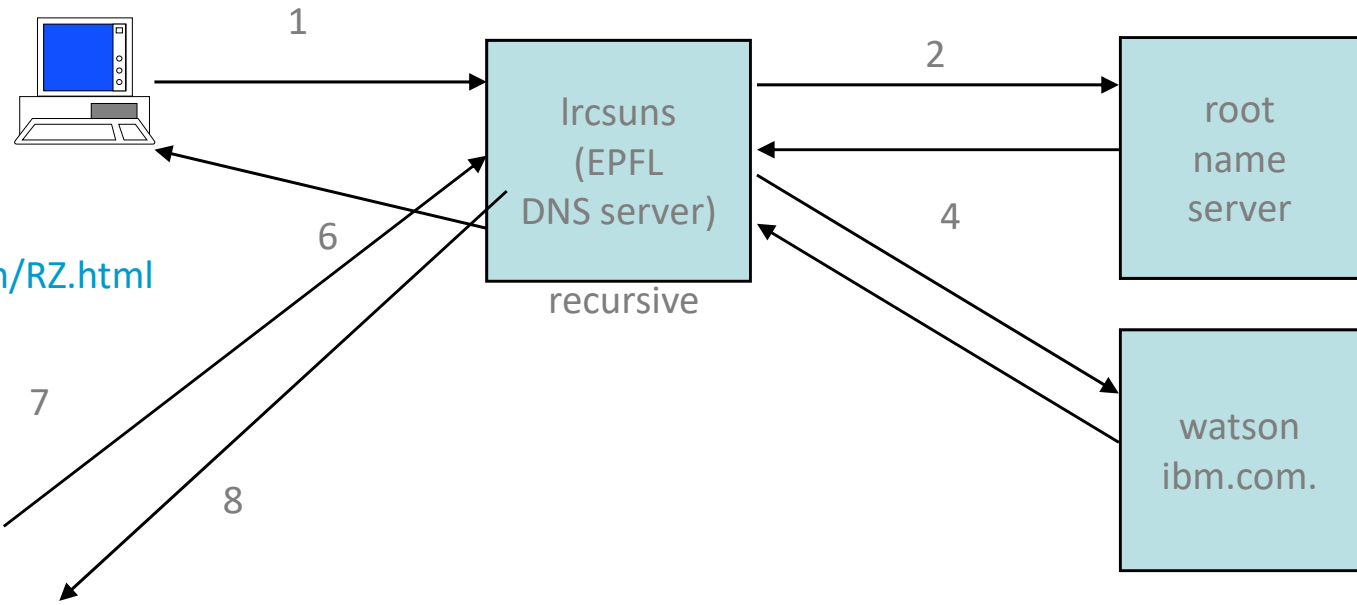

1mn later, Bart clicks:
<http://www.zurich.ibm.com/RZ.html>

7 query, RD=yes
 question = "www.zurich.ibm.com. A"

8 answer
 question = "www.zurich.ibm.com. A"
 answer = "www.zurich.ibm.com. 7140 A 193.5.61.131"

Reverse DNS Lookup

Reverse Query = find name, given some IP address; used e.g. by traceroute

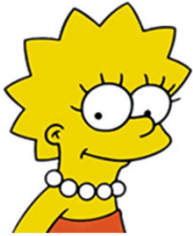

Lab 1a

Tracing route to read.more.at.beaglenetworks.net [216.81.59.173]
over a maximum of 64 hops:

1	2 ms	<1 ms	<1 ms	cv-ic-dit-v151-ro.epfl.ch [128.178
2	<1 ms	<1 ms	<1 ms	cv-gigado-v100.epfl.ch [128.178.10
3	<1 ms	<1 ms	<1 ms	c6-ext-v200.epfl.ch [128.178.200.1
4	<1 ms	<1 ms	<1 ms	swiel2.epfl.ch [192.33.209.33]
5	18 ms	<1 ms	3 ms	swiLS2-10GE-1-2.switch.ch [130.59.
6	4 ms	4 ms	4 ms	swiE71-10GE-2-7.switch.ch [130.59

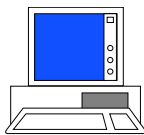

How does traceroute do DNS lookup ?

```
Tracing route to read.more.at.beaglenetworks.net [216.81.59.173]  
over a maximum of 64 hops:
```

```
  0  2 ms  <1 ms  <1 ms  cv-ic-dit-v151-ro.epfl.ch [128.178.200.1  
  1  <1 ms  <1 ms  <1 ms  cv-gigado-v100.epfl.ch [128.178.100.1  
  2  <1 ms  <1 ms  <1 ms  cv-out-r200-epfl.ch [128.178.200.1
```

- A. DNS client tries all possible DNS names and verifies each of them with DNS server
- B. DNS client asks DNS server: *what is the name corresponding to this IP address ?* and DNS server searches its database to find an answer
- C. Traceroute asks intermediate routers: *what is your DNS name ?*
- D. None of the above
- E. I don't know

Solution : Reverse DNS Lookup

Reverse Query = find name, given some IP address; used e.g. by traceroute

DNS servers do not do reverse search on A and AAAA records

Instead, reverse records (PTR) are used

IP addresses are first translated to domain names

128.178.151.1 -> 1.151.178.128.in-addr.arpa

in-addr.arpa = top level domain reserved for IPv4 addresses

ip6.arpa = top level domain reserved for IPv6 addresses

the reverse and direct records are written independently,
consistency is expected but not enforced

```
Z:\>dig 1.15.178.128.in-addr.arpa PTR
```

we are looking for the name corresponding to the IPv4 address 128.178.151.1

```
; <<>> DiG 9.3.2 <<>> 1.15.178.128.in-addr.arpa PTR
;; global options: printcmd
;; Got answer:
;; ->>HEADER<<- opcode: QUERY, status: NOERROR, id: 368
;; flags: qr aa rd ra; QUERY: 1, ANSWER: 1, AUTHORITY: 0, ADDITIONAL: 0
```

```
;; QUESTION SECTION:
;1.15.178.128.in-addr.arpa.  IN  PTR
```

```
;; ANSWER SECTION:
1.15.178.128.in-addr.arpa. 86400 IN  PTR  c6-slb-1-v15-ro.epfl.ch.
```

the name is found from a PTR record in DNS

```
;; Query time: 0 msec
;; SERVER: 128.178.15.227#53(128.178.15.227)
;; WHEN: Thu Aug 28 12:10:55 2014
;; MSG SIZE rcvd: 80
```

```
Z:\>dig c6-slb-1-v15-ro.epfl.ch
```

we verify that the IPv4 address for this name is as expected

```
; <<>> DiG 9.3.2 <<>> c6-slb-1-v15-ro.epfl.ch
;; ANSWER SECTION:
c6-slb-1-v15-ro.epfl.ch. 86400 IN  A  128.178.15.1
```

it is as expected, i.e. reverse record (PTR) and direct record (A) are consistent

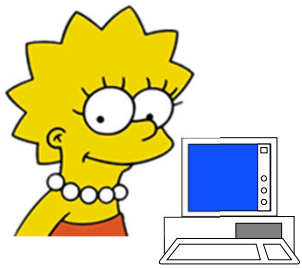

```

37 149 ms 149 ms 149 ms freedom.to.the.galaxy [206.214.251.89]
38 149 ms 150 ms 149 ms 0-----I-----I-----0 [206.214.251.94]
39 150 ms 151 ms 150 ms 0-----0 [206.214.251.97]
40 151 ms 150 ms 150 ms 0-----0 [206.214.251.102]

```

Z:\>dig 89.251.214.206.in-addr.arpa PTR

we are looking for the name corresponding to the IPv4 address 206.214.251.89

```

; <<>> DiG 9.3.2 <<>> 89.251.214.206.in-addr.arpa PTR
;; global options: printcmd
;; Got answer:
;; ->>HEADER<<- opcode: QUERY, status: NOERROR, id: 1223
;; flags: qr rd ra; QUERY: 1, ANSWER: 1, AUTHORITY: 0, ADDITIONAL: 0

```

the name is found from a PTR record in DNS

```

;; QUESTION SECTION:
;89.251.214.206.in-addr.arpa. IN PTR

```

```

;; ANSWER SECTION:
89.251.214.206.in-addr.arpa. 257 IN PTR freedom.to.the.galaxy.

```

we verify that the IPv4 address for this name is as expected

```

;; Query time: 2 msec
;; SERVER: 128.178.15.227#53(128.178.15.227)
;; WHEN: Thu Aug 28 11:43:34 2014
;; MSG SIZE rcvd: 80

```

this DNS name is bogus, there is no A (nor AAAA) record for it. The PTR record is bogus.

```

Z:\>ping freedom.to.the.galaxy.
Ping request could not find host freedom.to.the.galaxy.
Please check the name and try again.

```

DNS authority

DNS **authority** is hierarchical

Top level authority allocates top-level domains (e.g. .ch)

The top level is currently run by PTI (Public Technical Identifiers – formerly ICANN)

The 13 top-level DNS servers (root servers) are run by multiples companies

National **registry** allocates .ch domain names (in Switzerland: SWITCH)

Registar is a commercial organization accredited by registry to sell names (e.g. infomaniak.ch, register.ch, switchplus.ch)

DNS servers are run by ISPs or other organizations

namecoin is an attempt to provide peer-to-peer (= without authority)

DNS names for the domain .bit. It uses the blockchain technology.

DNS and Load Balancing

Why ?

sovkom.com is very popular and hosted on many servers. Traffic should be split between sites

How ?

One solution is to use a load balancing DNS server:

sovkom.com is mapped to many different addresses (or CNAMEs)

load balancing DNS server chooses one address (based on load, response time...)

TTL is very short to allow for frequent changes

```
sovkom.com 300 AAAA 2001: babe::b0b2
sovkom.com 300 AAAA 2001: b88b::b0bc
sovkom.com 300 AAAA 2001: b55b::b0ba
...
```

DNSSEC

DNS alone is unsecure even if servers are trusted
anyone can send (incorrect) answers to DNS queries

DNSSEC solves this problem

- Records are signed, using public key cryptography

- Chain of trust is initialized with root servers

- Some domains (such as .se) implement it systematically

- Some DNS servers (Google's 8.8.8.8 and 8.8.4.4) implement DNSSEC systematically

Alternative: DNS over TLS / over QUIC

Bonjour = Server-less DNS

Why invented ?

For names of local importance only : e.g. your printer at home

hp-laser2719.local

top level domain **local** is reserved for names visible in subnet

Uses multicast address **224.0.0.251/ff02::fb**, UDP port **5353**

Works only in one single (possibly bridged) LAN

We change the IPv4 address of lca.epfl.ch.
How long does it take for the whole world to be informed of the change ?

- A. less than a minute
- B. Up to 6 hours
- C. Up to 1 day
- D. Up to 2 days
- E. None of these
- F. I don't know

```
C:\Users\leboudec> dig a lca.epfl.ch
<<>> DiG 9.3.2 <<>> a lca.epfl.ch
;; global options: printcmd
;; Got answer:
;; ->>HEADER<<- opcode: QUERY, status: NOERROR, id: 12345
;; flags: qr aa rd ra; QUERY: 1, ANSWER: 2, AUTHORITY: 0, ADDITIONAL: 0

;; QUESTION SECTION:
;lca.epfl.ch.

;; ANSWER SECTION:
lca.epfl.ch.      86400 IN A 193.50.135.100
lca1srv2.epfl.ch.86400 IN A 193.50.135.101
```

EPFL names have TTL= 86400
secs, i.e. 1 day

Solution

EPFL names have TTL= 86400 secs, i.e. 1 day

It may take up to one day for the change to take effect

```
C:\Users\leboudec> dig a 1ca
<<>> DiG 9.3.2 <<>> a 1ca.
;; global options: print
;; Got answer:
;; ->>HEADER<<- opcode: QU
;; flags: qr aa rd ra; QUE

;; QUESTION SECTION:
;1ca.epfl.ch.

;; ANSWER SECTION:
1ca.epfl.ch.      86400
1ca1srv2.epfl.ch.86400
```

4. Application Layer Gateways (ALGs)

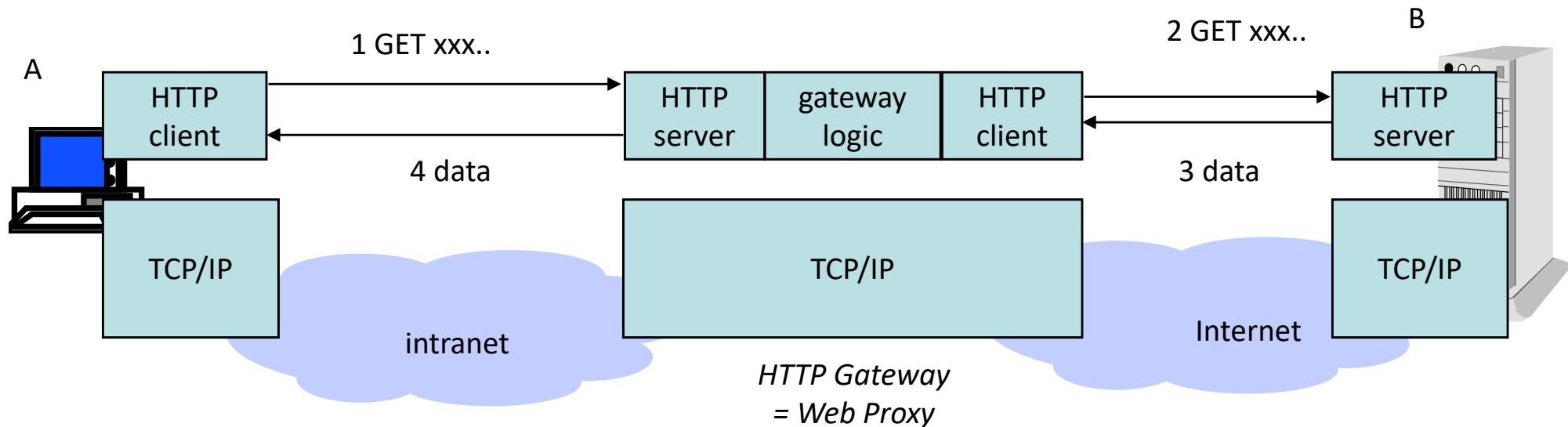

Definition: an *application layer gateway* is an application layer intermediate system. It terminates the TCP connections (if the application layer uses TCP) and does “store and forward” for the application layer data – it is another example of “middle box”

Example: HTTP gateway, also called “web proxy”

- ▶ A sends HTTP request to gateway, gateway sends another HTTP request to server, server sends objects to gateway, gateway sends objects to A
- ▶ Gateway terminates the TCP connections and does “store and forward”

Web Proxy can be deployed to reduce traffic

HTTP Intermediate Systems can keep frequently asked documents close to user

- ▶ requested files are kept in a cache
- ▶ similar systems deployed in content distribution networks

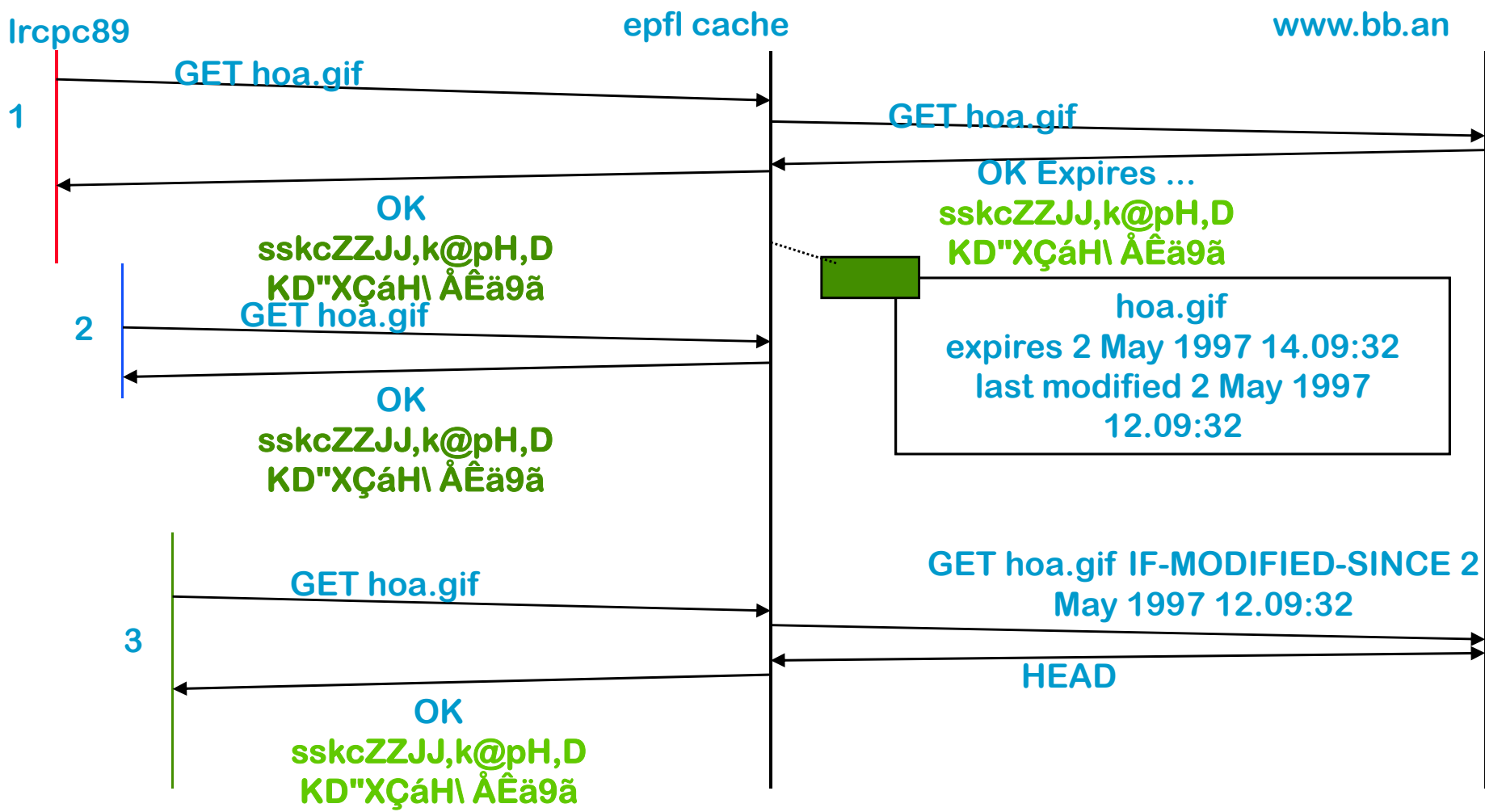

The “End-to-end” Principle

The “end-to-end” principle of the Internet says that any layer above the network layer should avoid intermediate systems

- ▶ Thus: Application Layer Gateways should be avoided

Why ?

- ▶ Simplify the network. The network is independent of applications and can be run more safely.
- ▶ Allow easy deployment of applications. Ex: the web was deployed in 1994 in a few months. Before that, TCP/IP existed, but not HTTP.
- ▶ Performance is better – no store and forward

The “End-to-end” Principle for Email

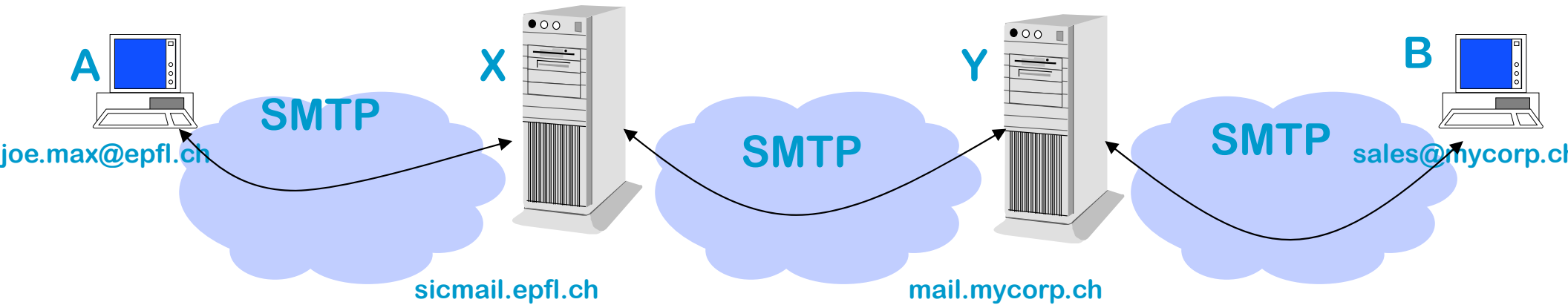

Q. what would a strict application of the end-to-end principle on the figure give ?

Solution

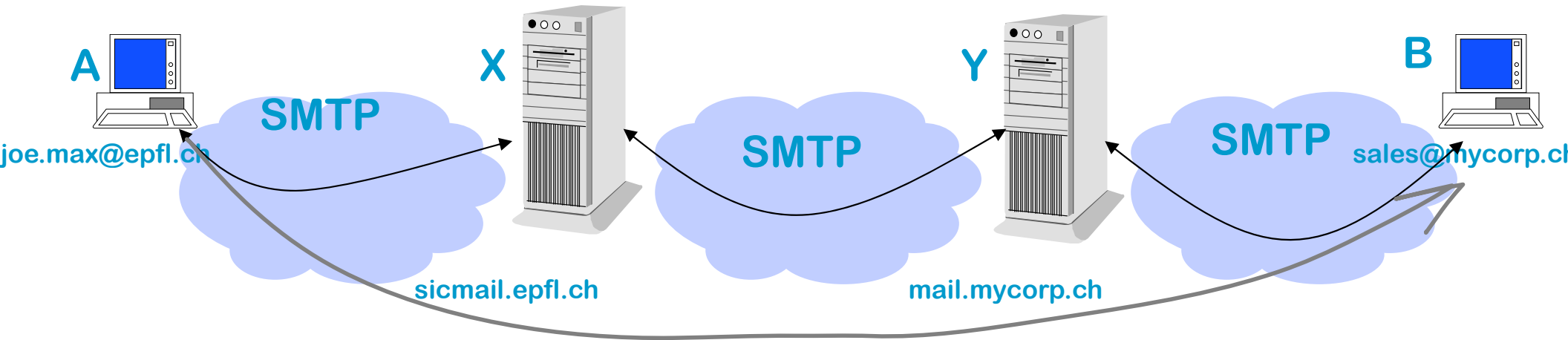

Q. what would a strict application of the end-to-end principle on the previous figure give ?

A. PC A should open a TCP connection directly to B and transfer the email over the connection. This is not possible here since PCs are not expected to be always available for service, as an email server is. However, one could require that A directly opens a TCP connection to email server Y instead of going through email server X.

The End-to-end Principle is not always Applicable

Application layer gateways are still desirable in some cases.

Q. Can you mention three good reasons for desiring an application layer gateway ?



Attention!

L'accès à cette page a été bloqué pour des raisons de sécurité.

IP: 10.4.147.134

Application: slideshare-base

Solution

For Example

1. **Mobility** (or partial connectivity). On the previous figure, this is why we send email to Y and not to B.
2. **Security / Access Control**. X connects to the internet through web proxy S.
S can deny access to some web sites.
3. **Interworking**. Interworking between IPv4 and IPv6.
4. **Performance**. Counter TCP deficiencies on wireless links, Load balancers



Attention!

L'accès à cette page a été bloqué pour des raisons de sécurité.

IP: 10.4.147.134

Application: slideshare-base

Server-Side Load Balancers

Server-side
Load balancers are
application-layer
gateways: they
terminate TCP or
QUIC
connections
and re-direct
user request to
one of the
application servers.

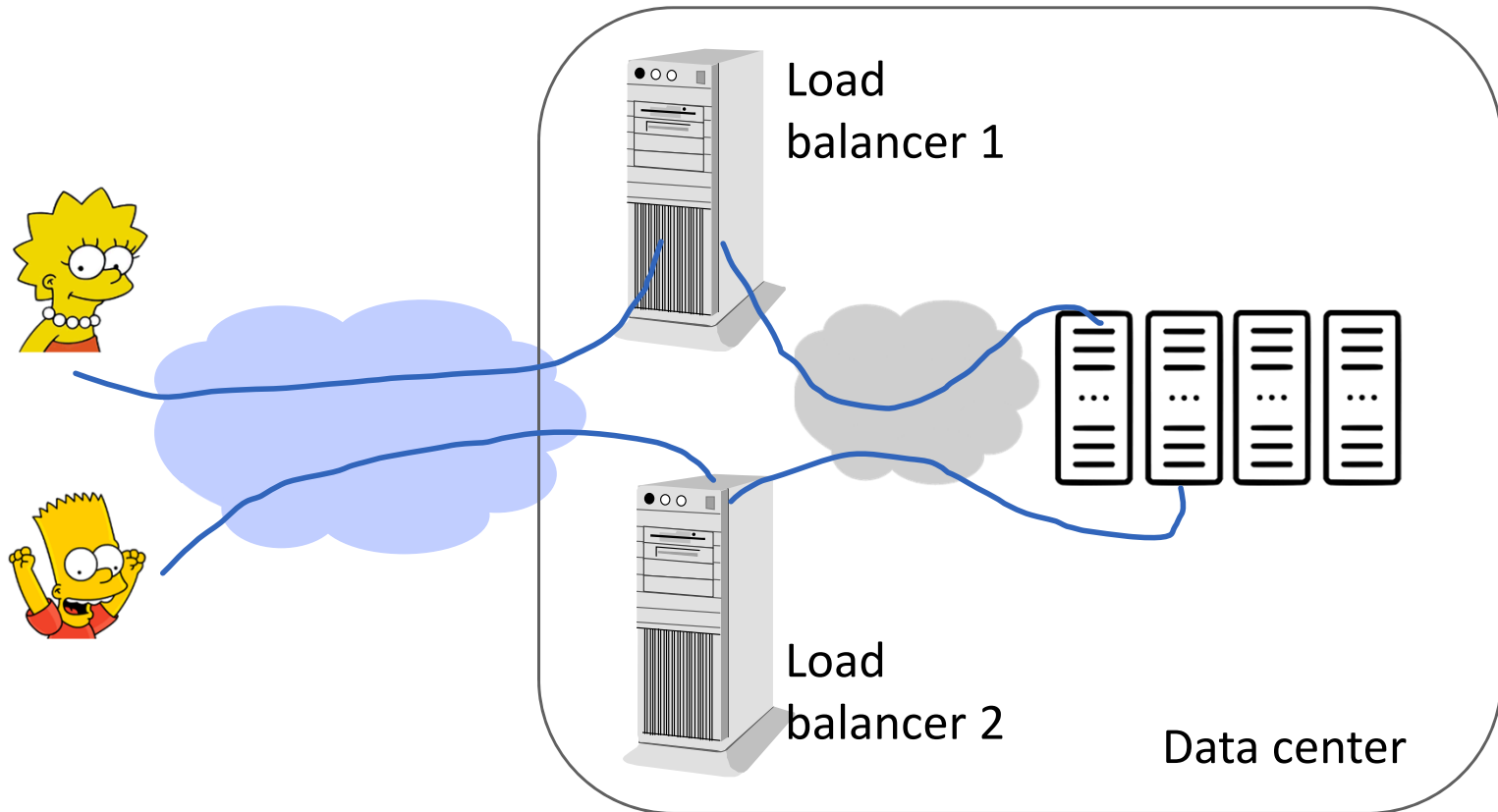

Load balancers are replicated for reliability.
How is user traffic split among load balancers ?

Solution

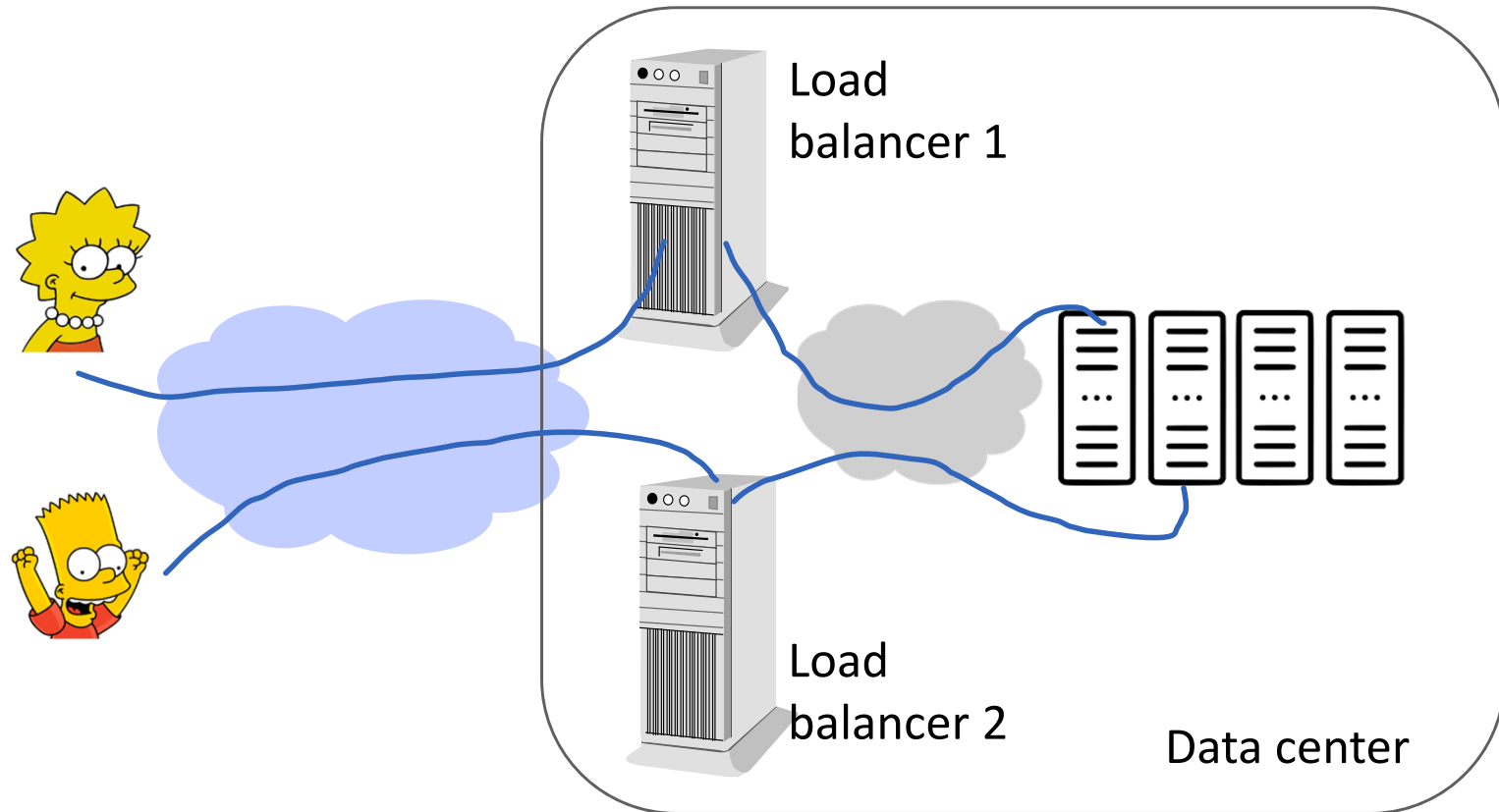

DNS load balancing is possible but is perhaps better adapted to splitting traffic across multiple sites.

Equal Cost Multipath Routing is typically used in the access routers: with this solution, the IP address of the service is allocated to both Load Balancers 1 and 2. The access routers route randomly to one of the two load balancers using ECMP and per-flow load balancing.

Firewalls use ALGs

Firewall = a system that separates Internet from intranet: all traffic must go through firewall; only authorized traffic may go through; firewall itself cannot be penetrated (as one thinks)

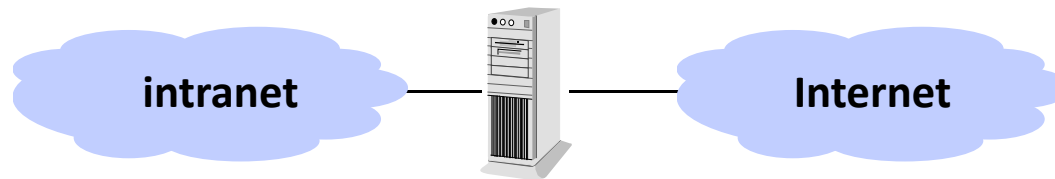

**Firewall =
one dual homed application layer gateway**

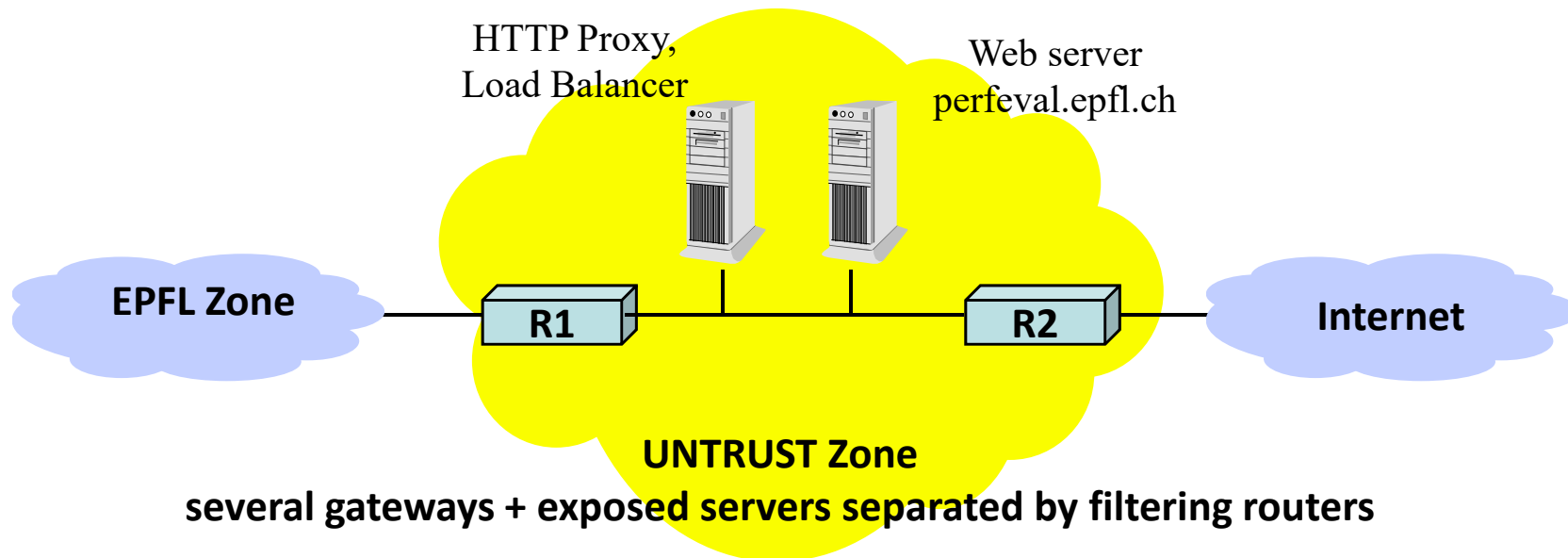

several gateways + exposed servers separated by filtering routers

A packet is lost in the transfer from data center to Lisa. Which system will retransmit it ?

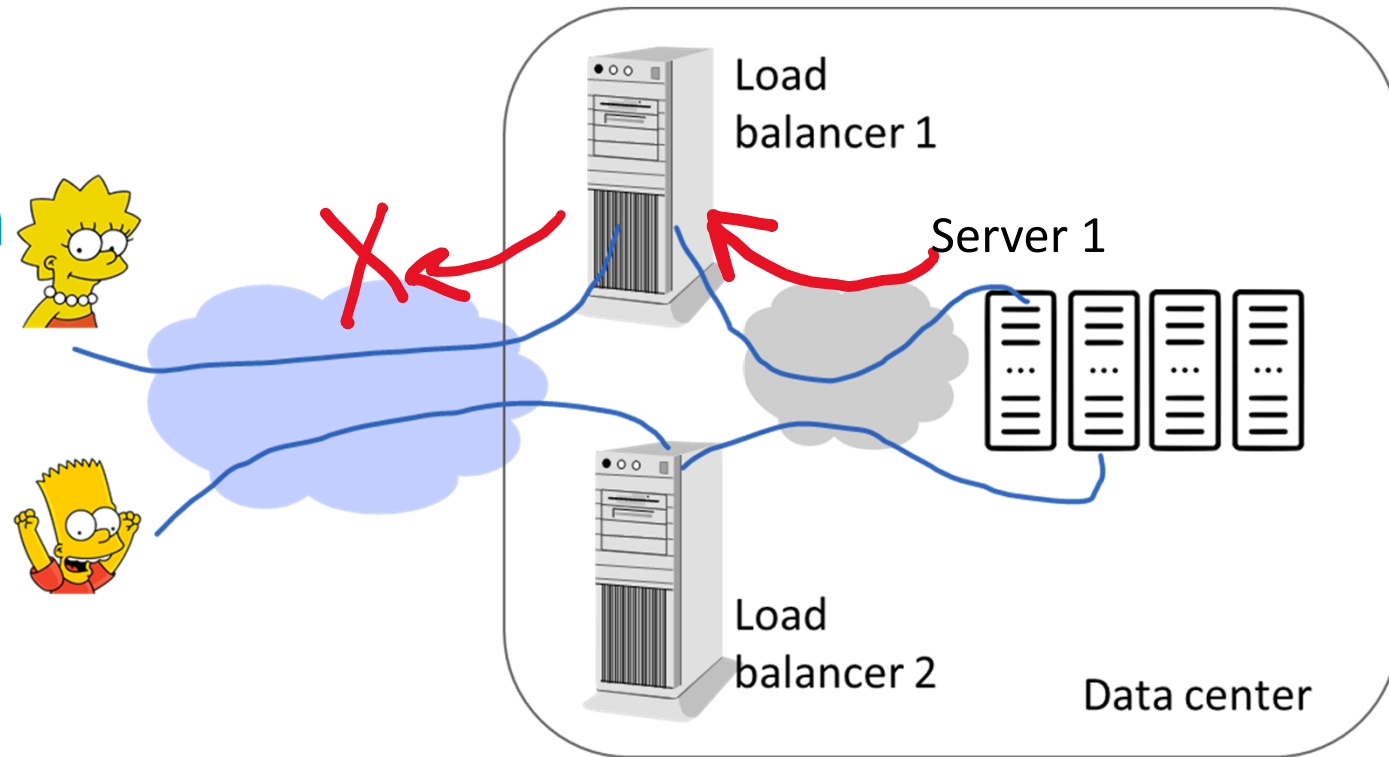

- A. Load balancer 1
- B. With QUIC: Load Balancer 1; with TCP: Server 1
- C. With TCP: Load Balancer 1; with QUIC: Server 1
- D. Server 1
- E. I don't know

Solution

Answer A

The load balancer terminates the TCP or QUIC connection and acts as an Application Layer Gateway. There is one TCP or QUIC connection between load balancer and A.

5. The Application Layer has to select IPv4 or IPv6 sockets

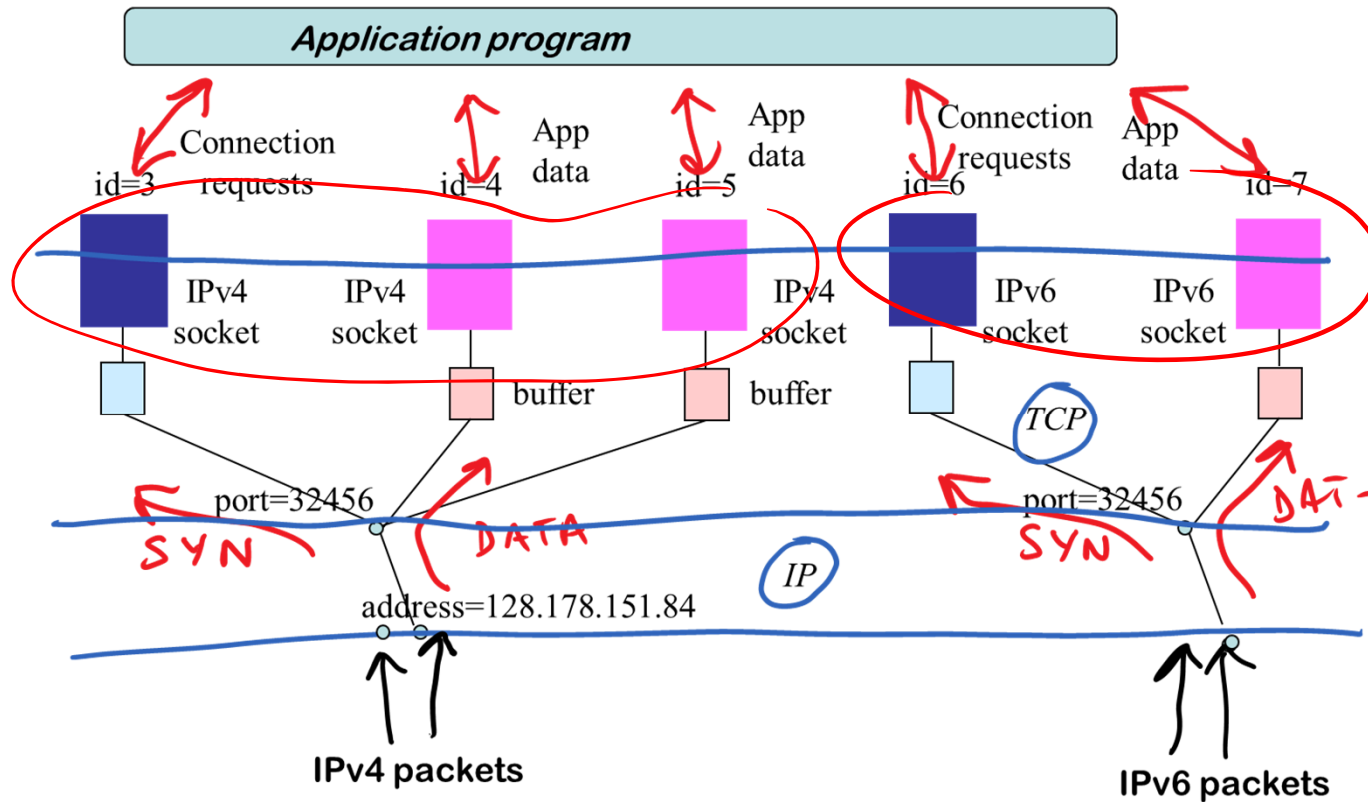

Application layer programs must be explicitly choose IPv4 or IPv6 sockets

Old programs can use only IPv4; newer ones can use IPv4 and IPv6 sockets

Note that application layer *protocols* (such as HTTP) are independent of the version of IP (IPv4/IPv6)

A Dual Stack Host with up-to-date application code can use both IPv4 and IPv6

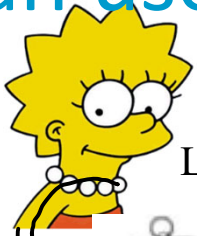

Lisa's PC

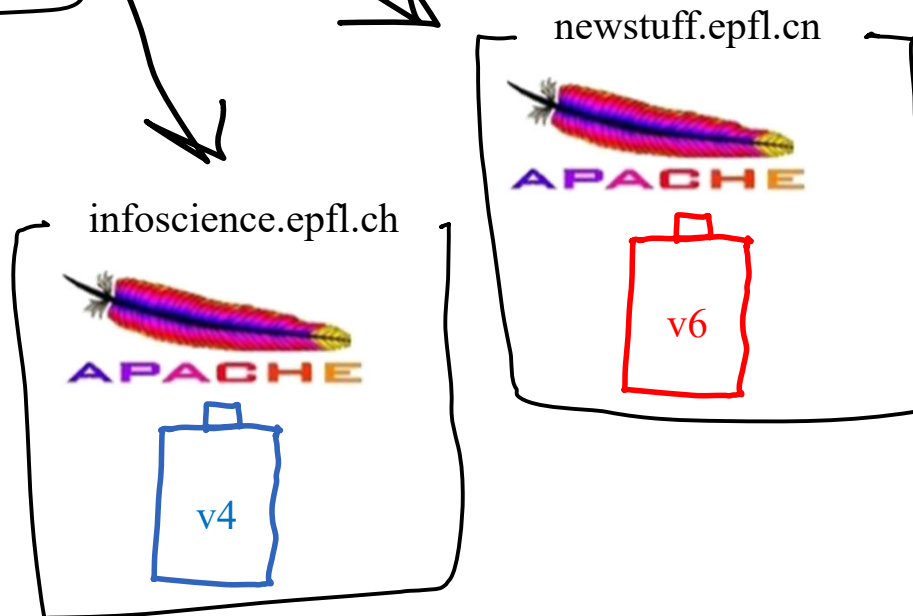
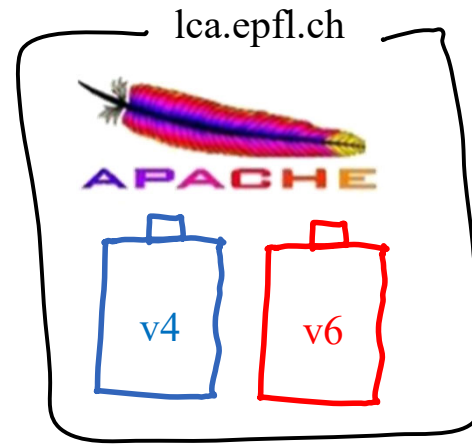
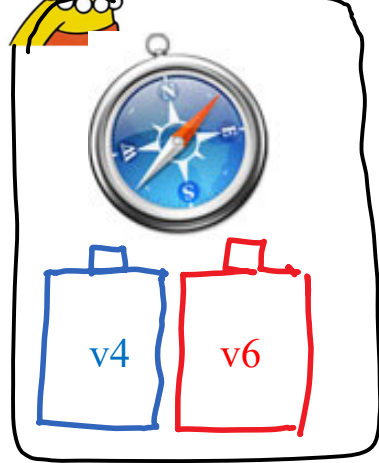

Will Lisa use IPv4 or IPv6 to connect to lca.epfl.ch ?

Solution

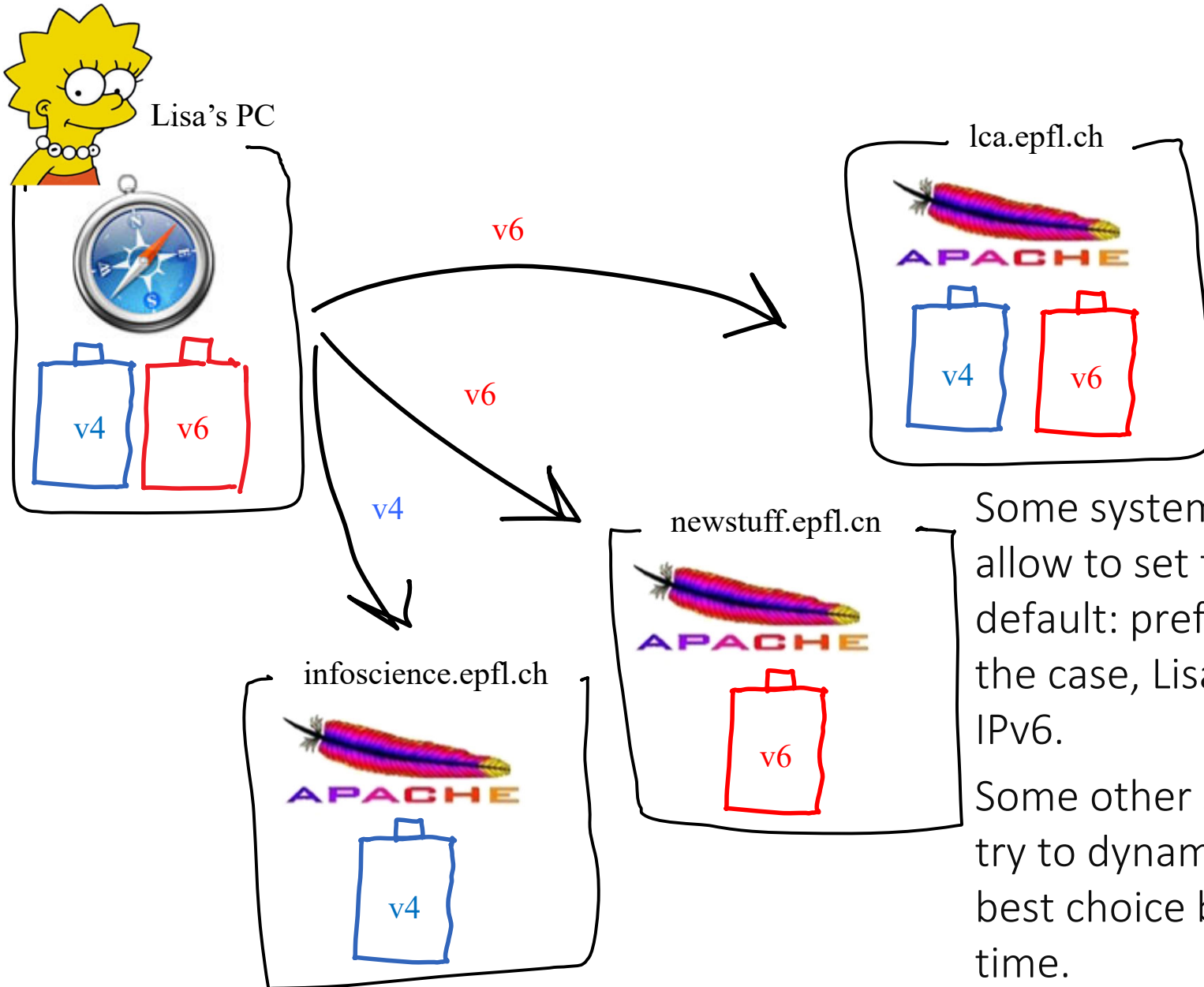

Some systems (Windows/Linux allow to set the preference - by default: prefer IPv6). If this is the case, Lisa will connect via IPv6.

Some other systems (e.g. OSX) try to dynamically select the best choice based on response time.

How does Lisa know whether other end is v4 or v6 ?

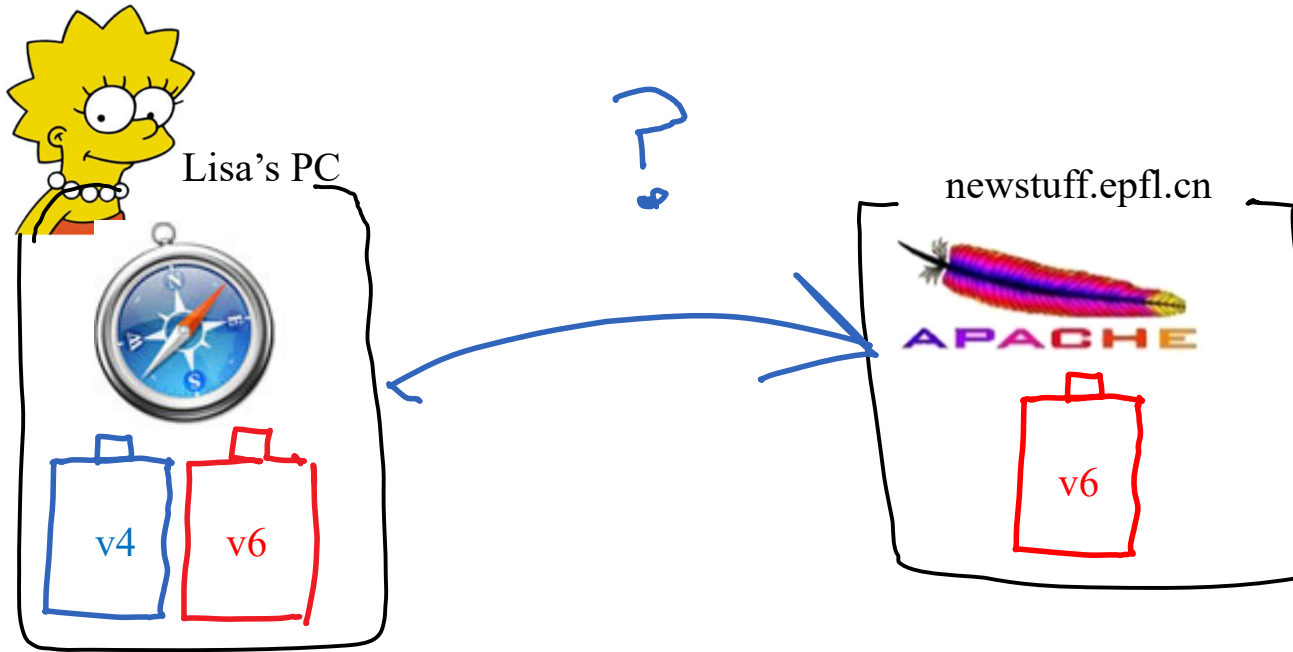

- A. Lisa's PC sends a ping to newstuff.epfl.cn
- B. Lisa's PC tries http over both IPv4 and IPv6 in parallel and sees what works
- C. None of the above
- D. I don't know

Solution: DNS is used by application layer to know if other end is IPv4 or IPv6

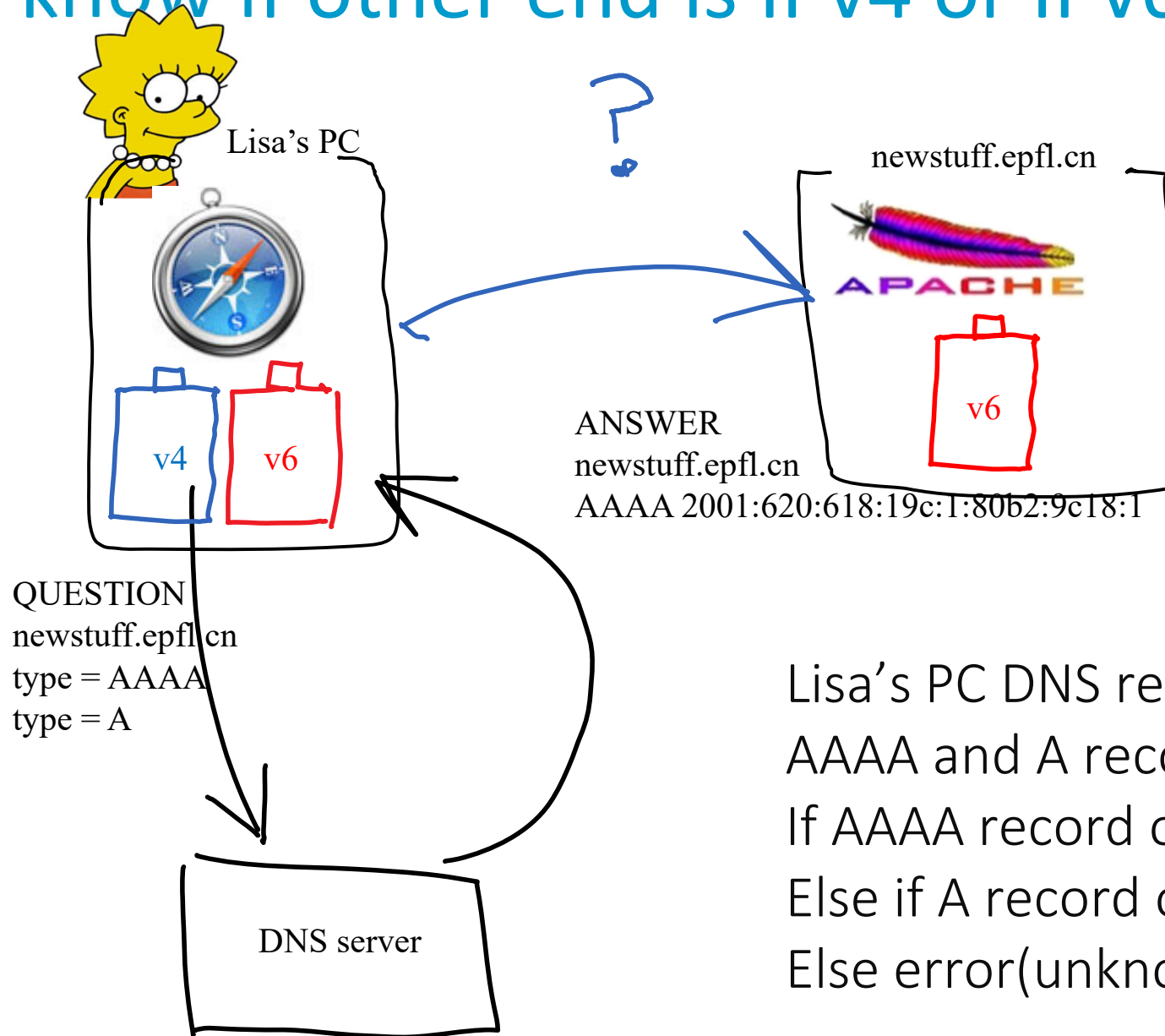

Lisa's PC DNS resolver asks for both AAAA and A records
If AAAA record obtained, use IPv6
Else if A record obtained, use IPv4
Else error(unknown host)

DNS can be accessed via IPv4 or IPv6

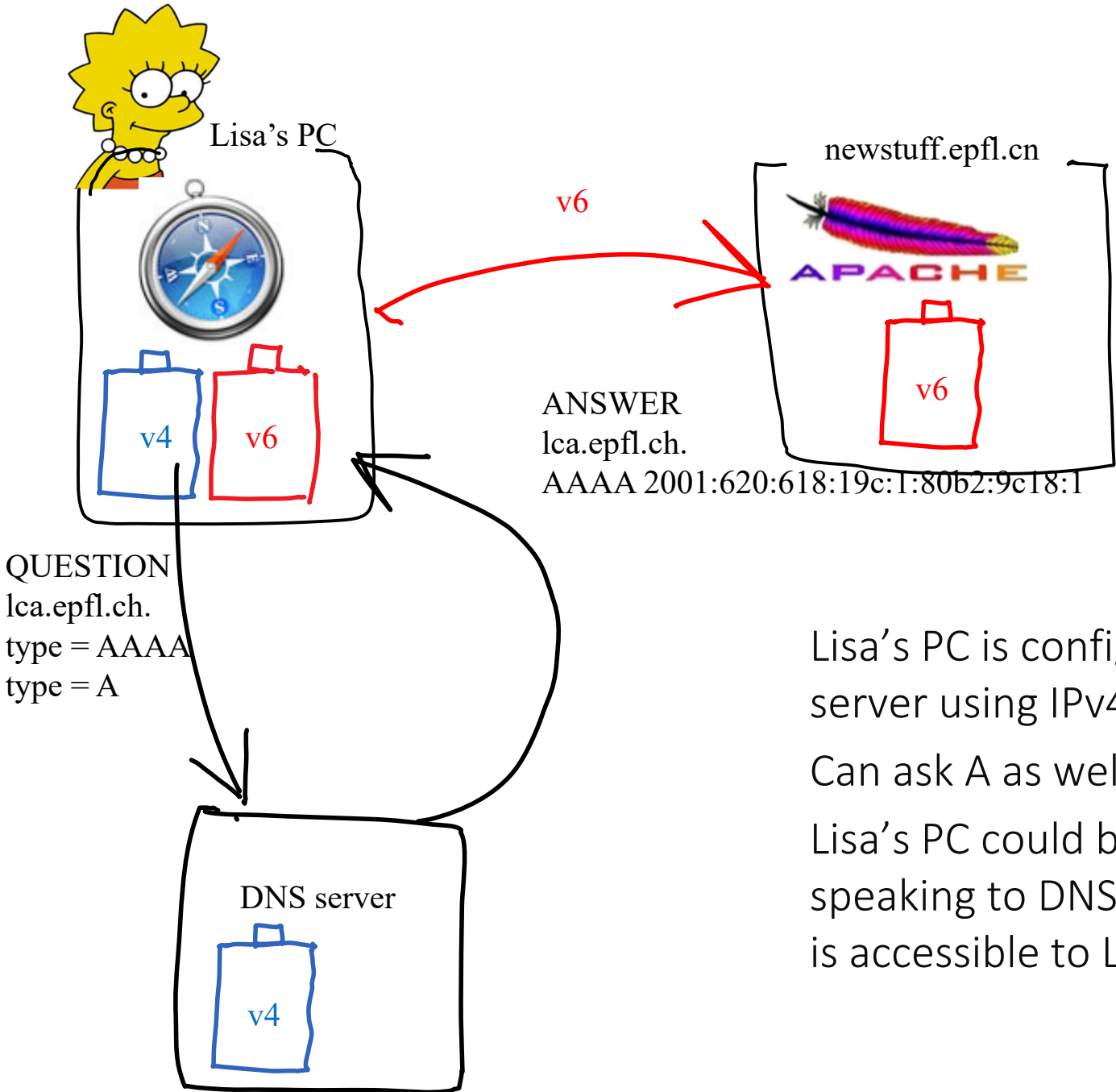

Lisa's PC is configured to talk to a DNS server using IPv4
Can ask A as well as AAAA questions
Lisa's PC could be configured to use v6 for speaking to DNS server, if a v6 DNS servers is accessible to Lisa's PC

```
PS C:\Users\leboudec> nslookup
Default Server: stisun1.epfl.ch
Address: 2001:620:618:10f:1:80b2:f08:1
```

```
> infoscience.epfl.ch
Server: stisun1.epfl.ch
Address: 2001:620:618:10f:1:80b2:f08:1
```

```
Name: ec2-34-250-186-131.eu-west-1.compute.amazonaws.com
Address: 34.250.186.131
Aliases: infoscience.epfl.ch
```

```
> www.epfl.ch
Name: www.epfl.ch.cdn.cloudflare.net
Addresses: 2606:4700:10::6814:e42a
           2606:4700:10::6814:e52a
           104.20.228.42
           104.20.229.42
Aliases: www.epfl.ch
```

6. ALG46 IPv4 and IPv6 Interworking with Application Layer Gateways

IPv4 and IPv6 are incompatible

- ▶ v4 only host cannot handle IPv6 packets
- ▶ v6 only host cannot handle IPv4 packets



What needs to be solved:

Interworking (h4 to h6): allow IPv6-only hosts and IPv4-only hosts to communicate

- ▶ example: IPv6 host connects to an IPv4 web server

like to like access

- ▶ 6 to 6 over IPv4 infrastructure; ex: IPv6 host at home connects to IPv6 server at EPFL
- ▶ 4 to 4 over IPv6; in a distant future

In this section we study interworking.

Dual Stack Application Layer Gateways (ALG46s) can be used to solve h4 to h6 Interworking

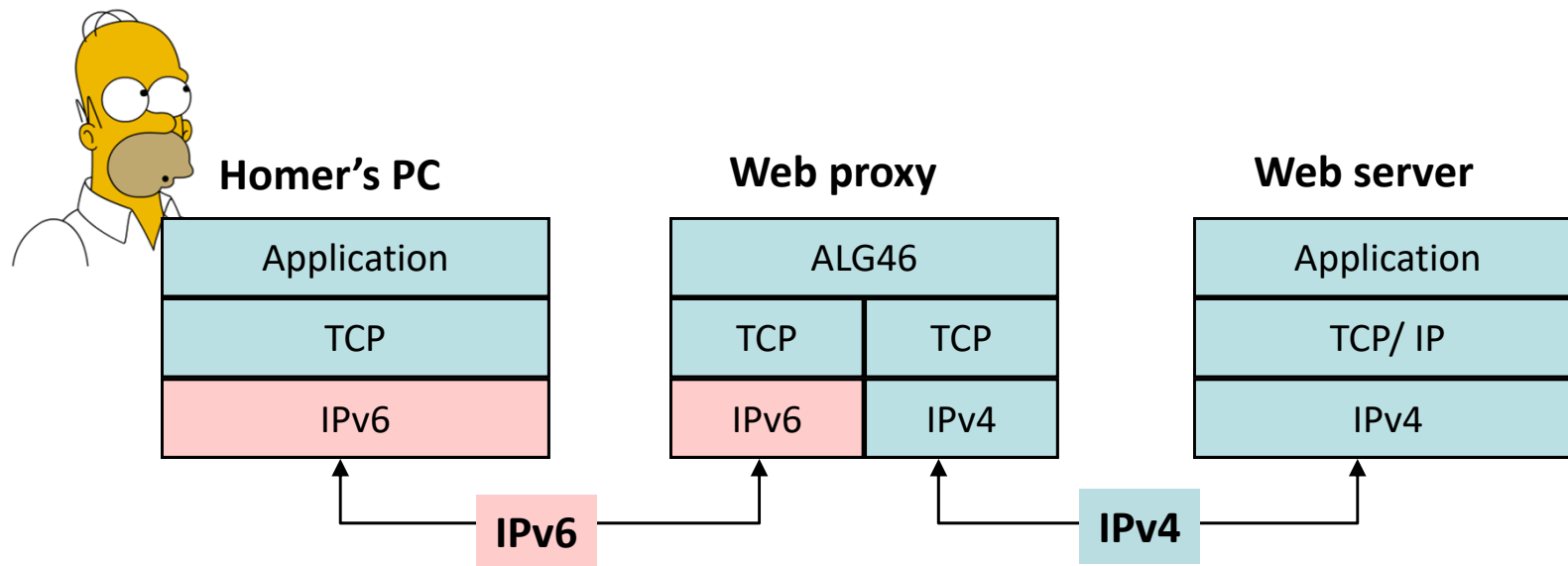

Application layer gateway (e.g. web proxy) relays HTTP questions / answers.

ALG must be dual stack

How does Homer's PC know it should go to the ALG instead of the final web server ?

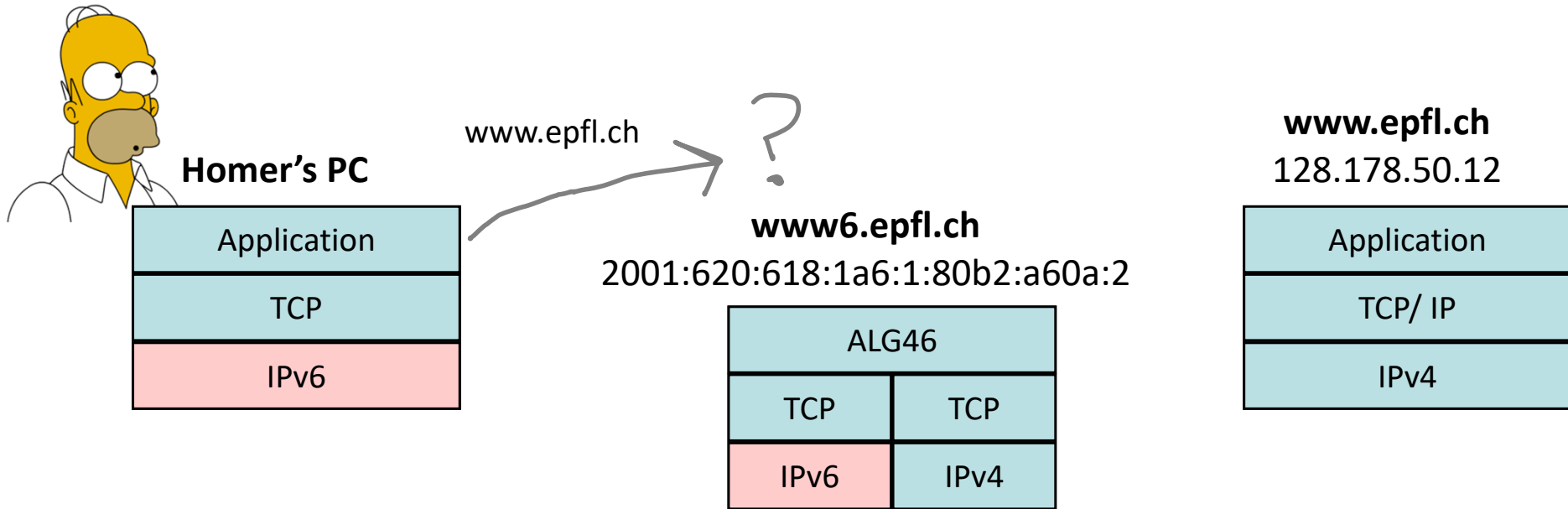

Solution: via DNS

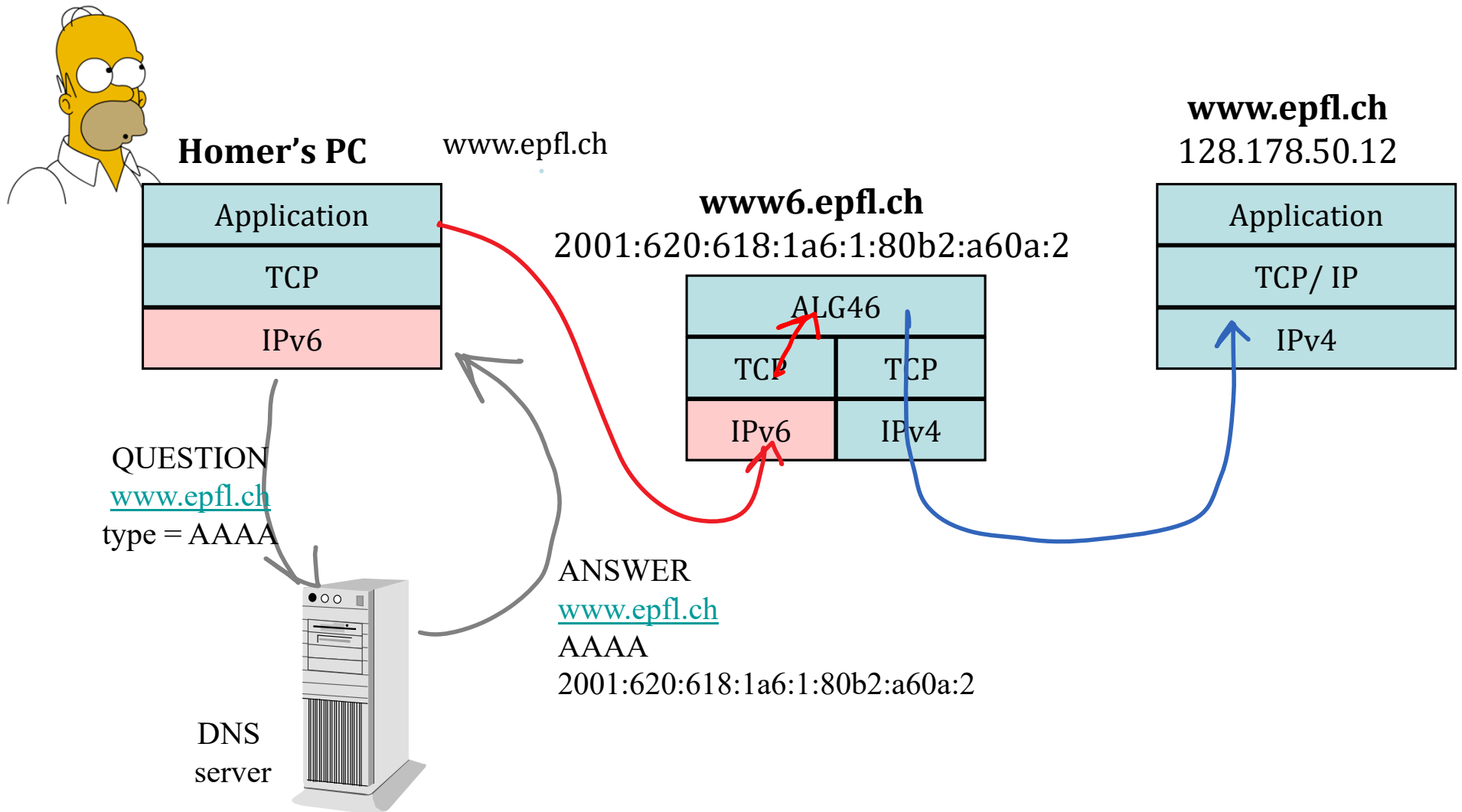

Bart's PC will not use the ALG

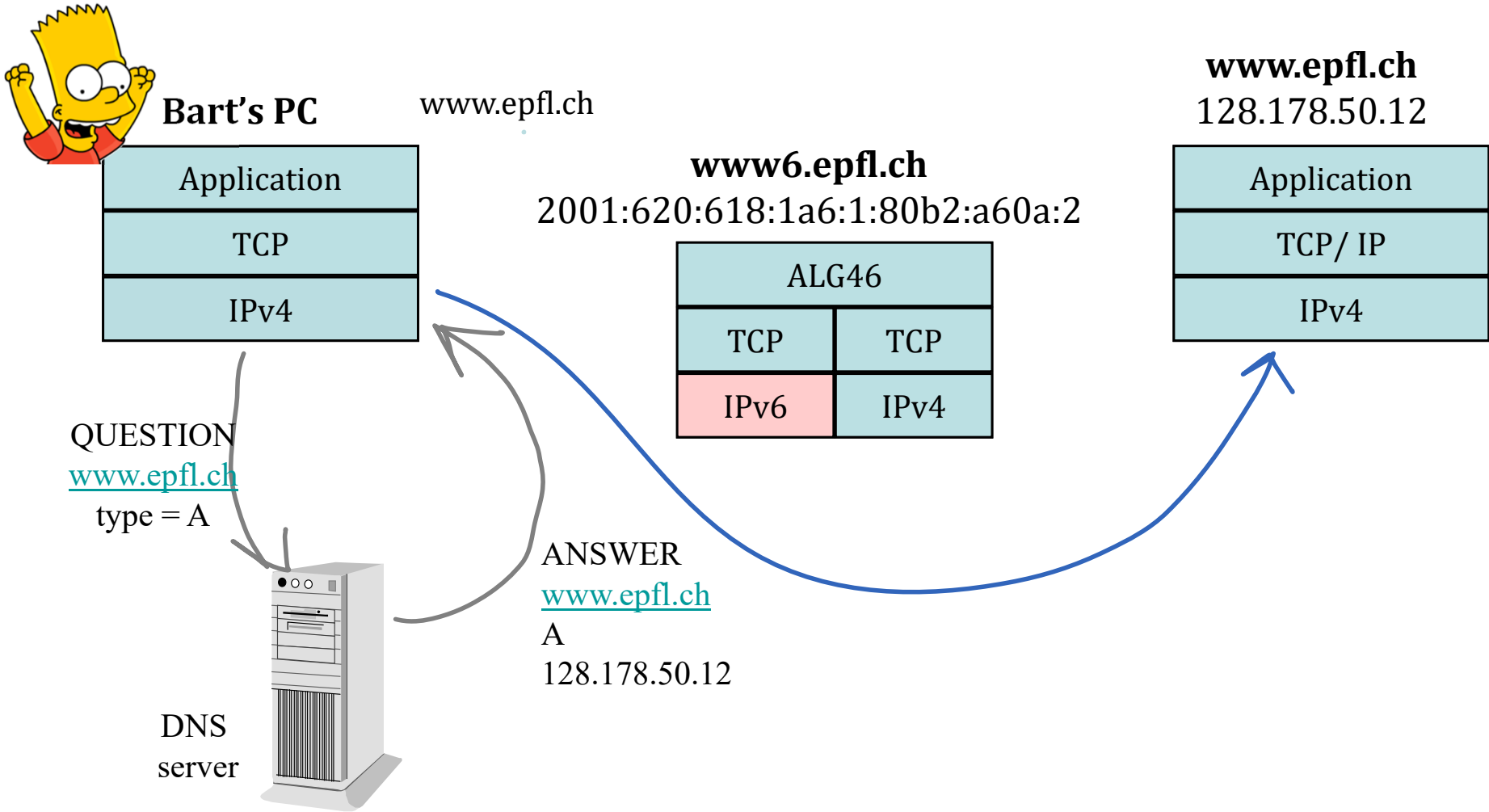

Will Lisa's PC use the ALG ?



Lisa's PC

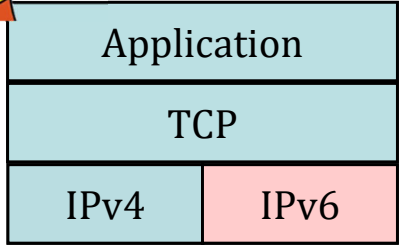

www.epfl.ch

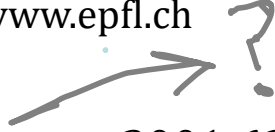

www6.epfl.ch

2001:620:618:1a6:1:80b2:a60a:2

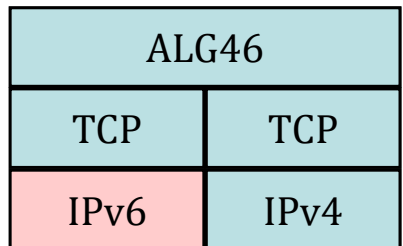

www.epfl.ch
128.178.50.12

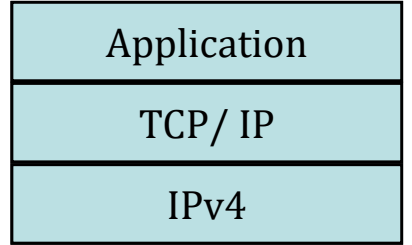

- A. Yes
- B. No
- C. It depends on the configuration
- D. I don't know

Solution

It depends on the v6/v4 preference of Lisa's OS.

If it prefers IPv6, Lisa connects via IPv6 and will suffer higher latency (due to the additional ALG)!

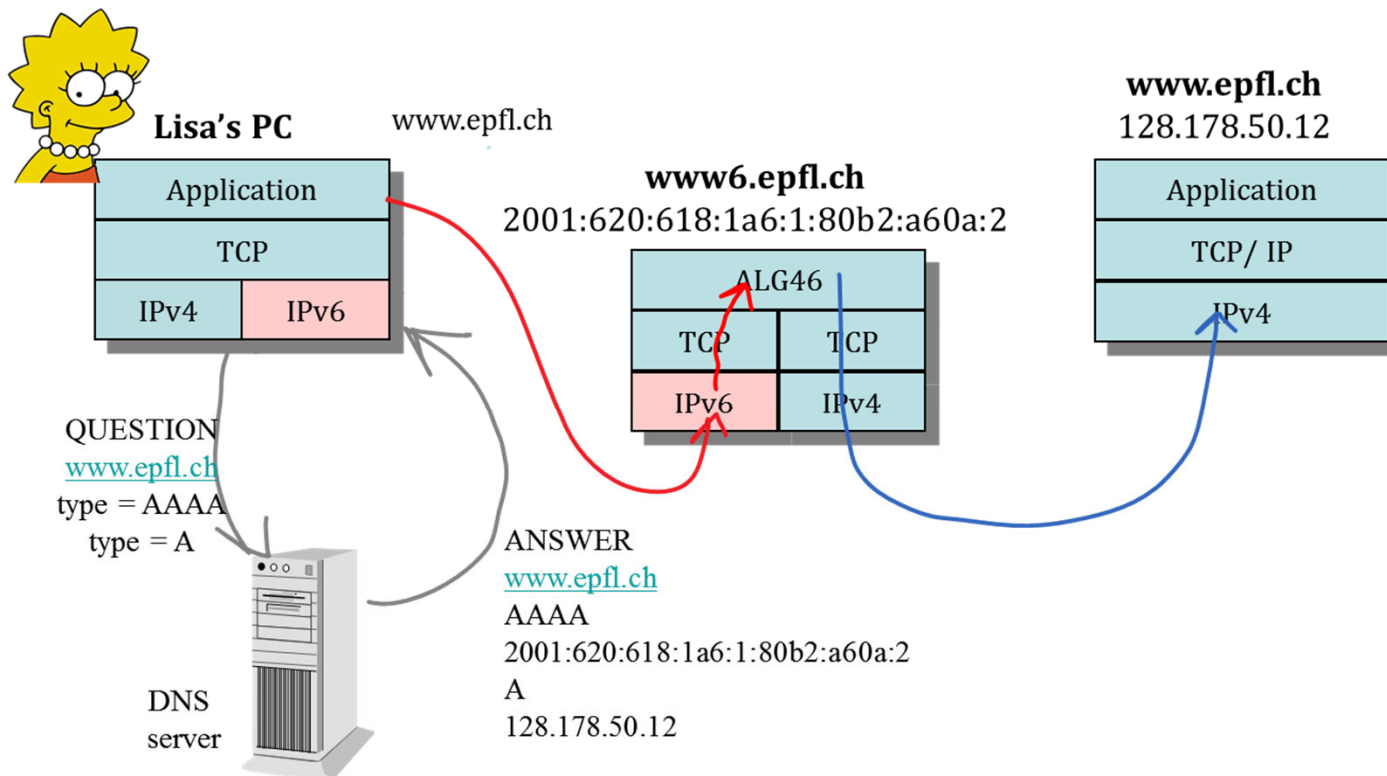

Pros and Cons of ALG46

+

Transparent to end-users (no software change)
No change in server software – easy deployment

–

This is store and forward... therefore the performance is not good / or the cost is high (disks, CPUs)
One ALG logic for every service (http, email, etc)

Facts to Remember

Application layer runs on hosts, not routers

Application layer gateways (ALGs) should be avoided whenever possible (“end to end principle”) but are deployed e.g. for load balancing / security

Application chooses UDP or TCP and must be able to use both IPv4 and IPv6; old apps use IPv4 only

DNS is a worldwide distributed data base used for mapping names to IP addresses (and vice versa)

DNS requires DNSSEC to be secure

DNS is used by apps on dual stack machines to know whether to use v4 or v6

ALG46s can be used to solve the h4 to h6 interworking problem