

Shape from X

- One image:
 - Shading
 - **Texture**
- Two images or more:
 - Stereo
 - Contours
 - Motion

Shape From X

- One image:
 - Shading
 - **Texture**
- Two images or more:
 - Stereo
 - Contours
 - Motion

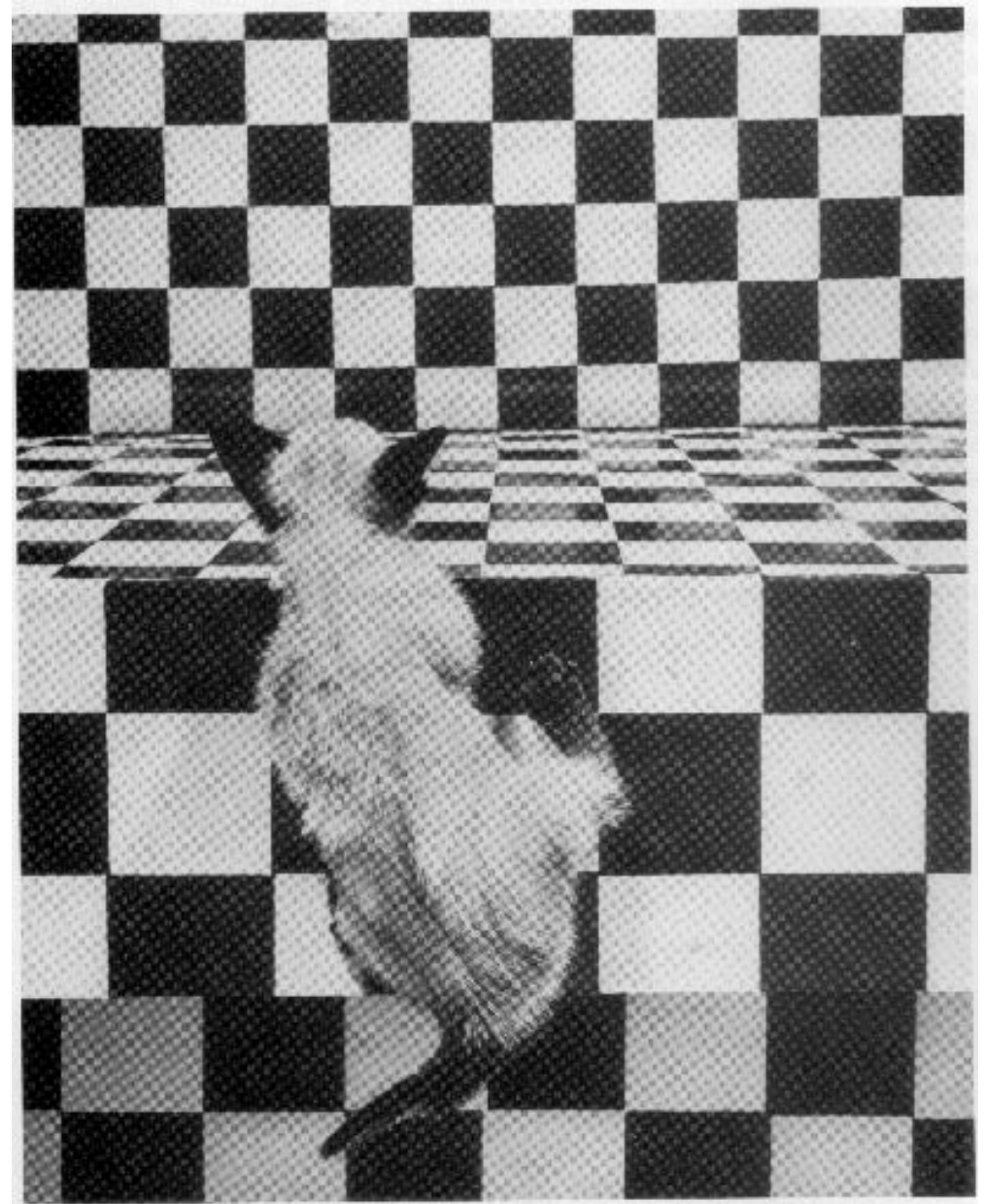

Shape From Texture

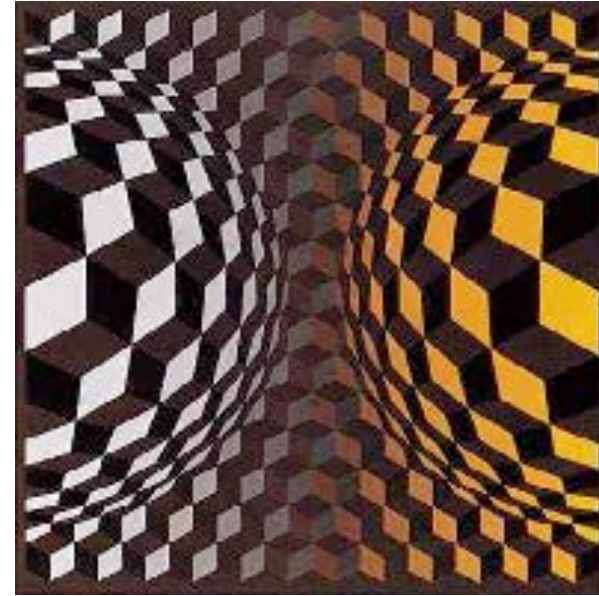

Recover surface orientation or surface shape from image texture:

- Assume texture 'looks the same' at different points on the surface.
- This means that the deformation of the texture is due to the surface curvature.

Structural Shape Recovery

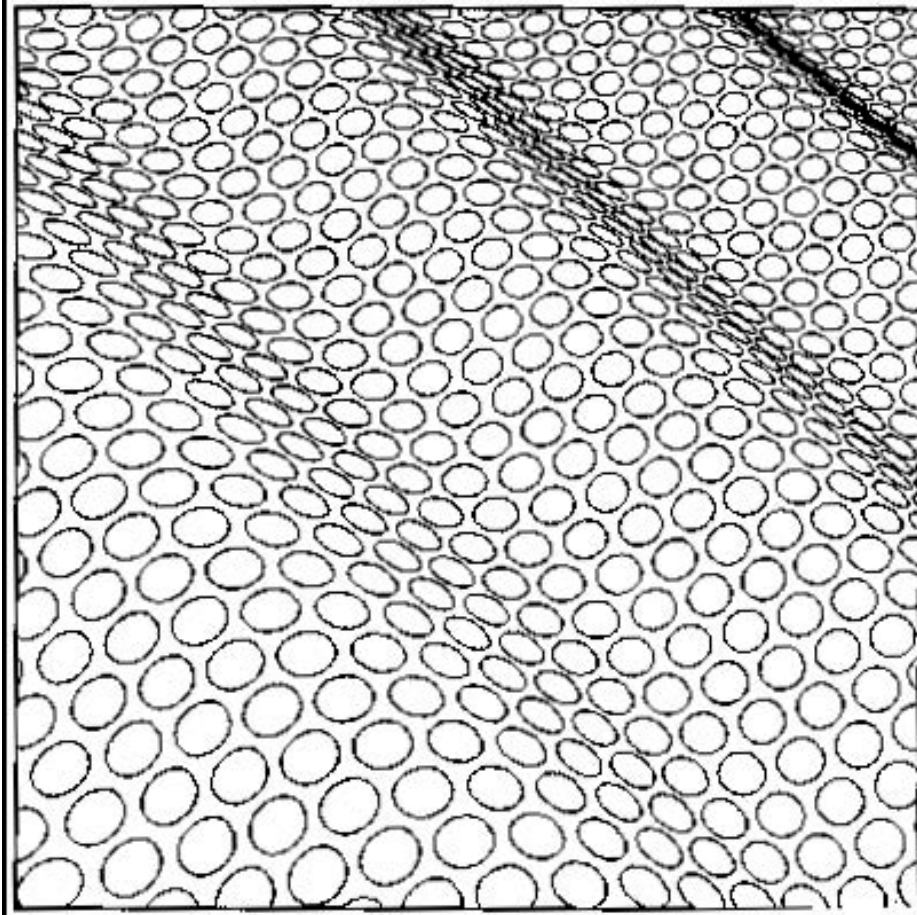

Basic hypothesis: Texture resides on the surface and has no thickness.

—> Computation under:

- Perspective projection
- Paraperspective projection
- Orthographic projection

Reminder: Perspective Projection

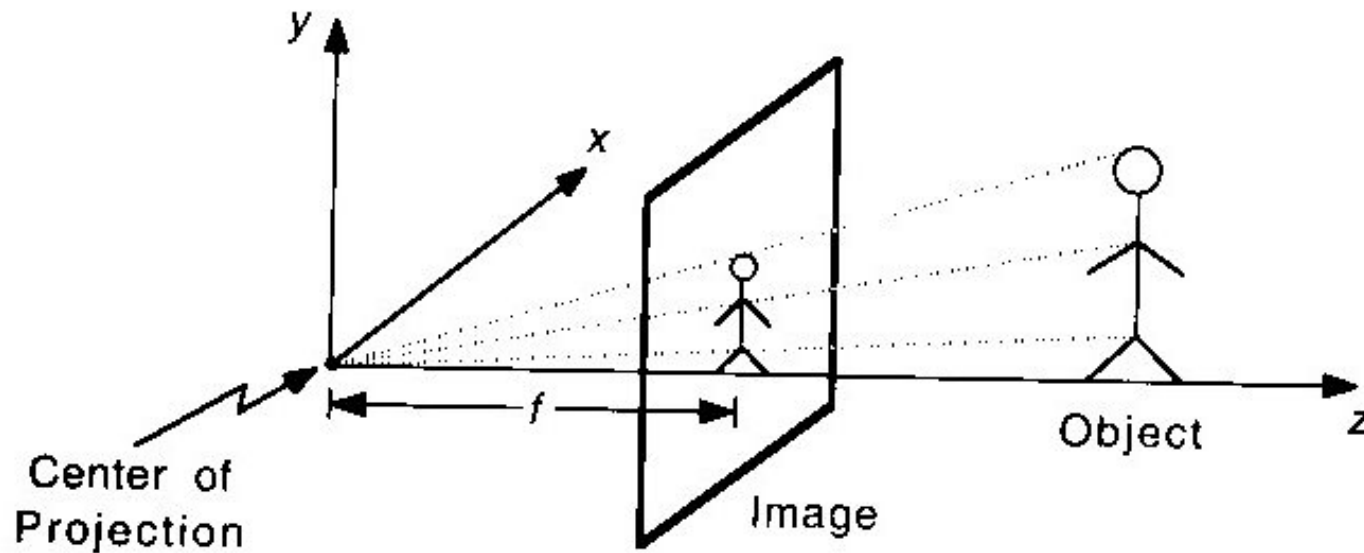

$$u = f \frac{x}{z}$$
$$v = f \frac{y}{z}$$

Perspective Distortion

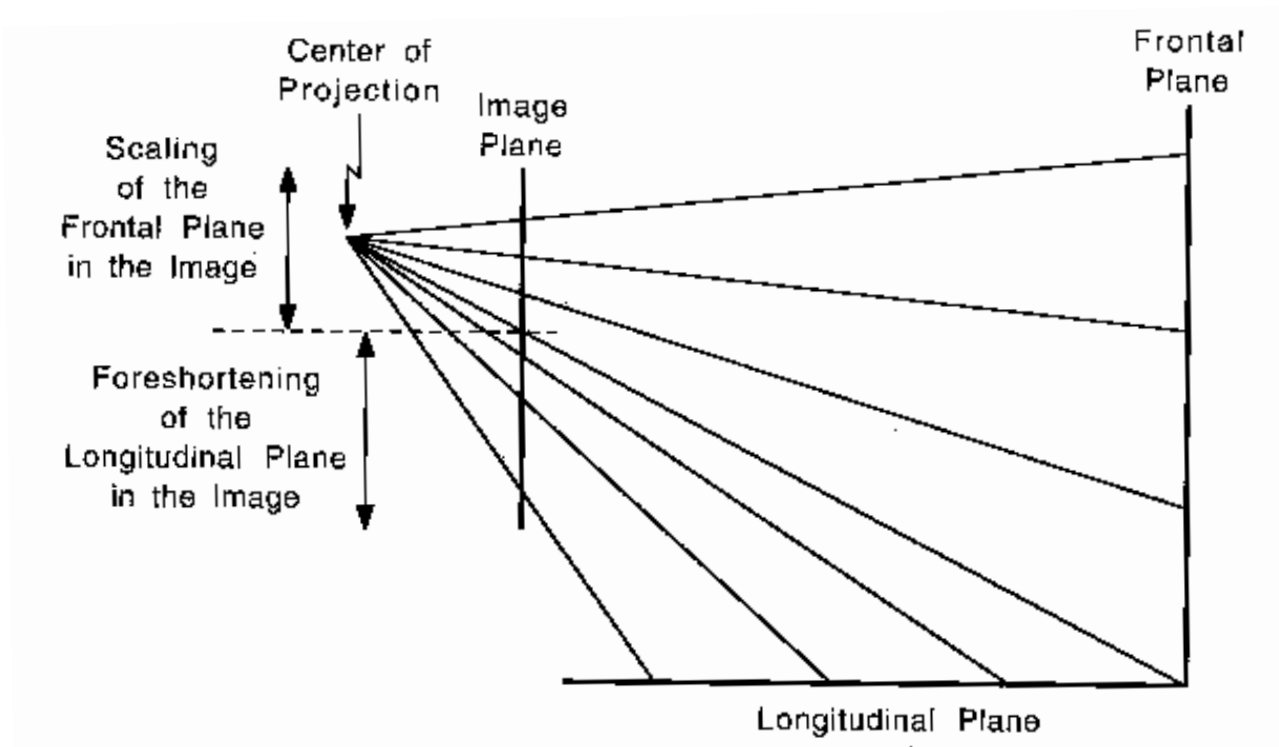

- The perspective projection distortion of the texture
- depends on both depth and surface orientation,
 - is anisotropic.

Foreshortening

Depth vs Orientation:

- Infinitesimal vector $[\Delta x, \Delta y, \Delta z]$ at location $[x, y, z]$
image of this vector is

$$\frac{f}{z} \left[\Delta x - \frac{x}{z} \Delta z, \Delta y - \frac{y}{z} \Delta z \right]$$

- Two special cases:

- $\Delta z = 0$:

The object is scaled

- $\Delta x = \Delta y = 0$:

The object is foreshortened

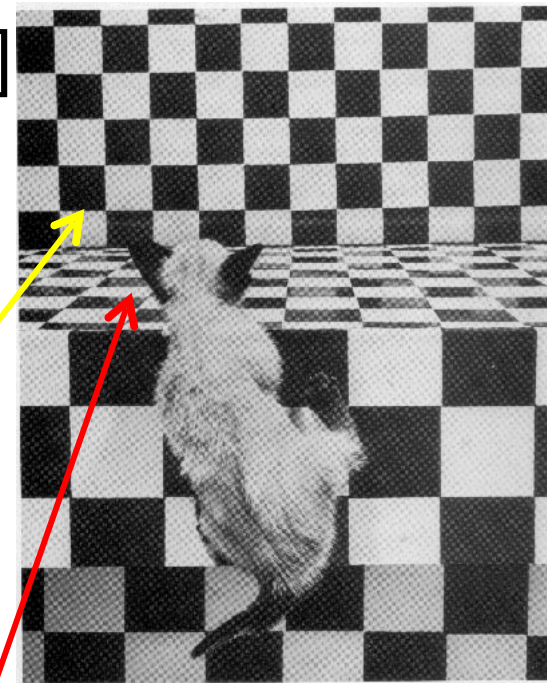

Orthographic Projection

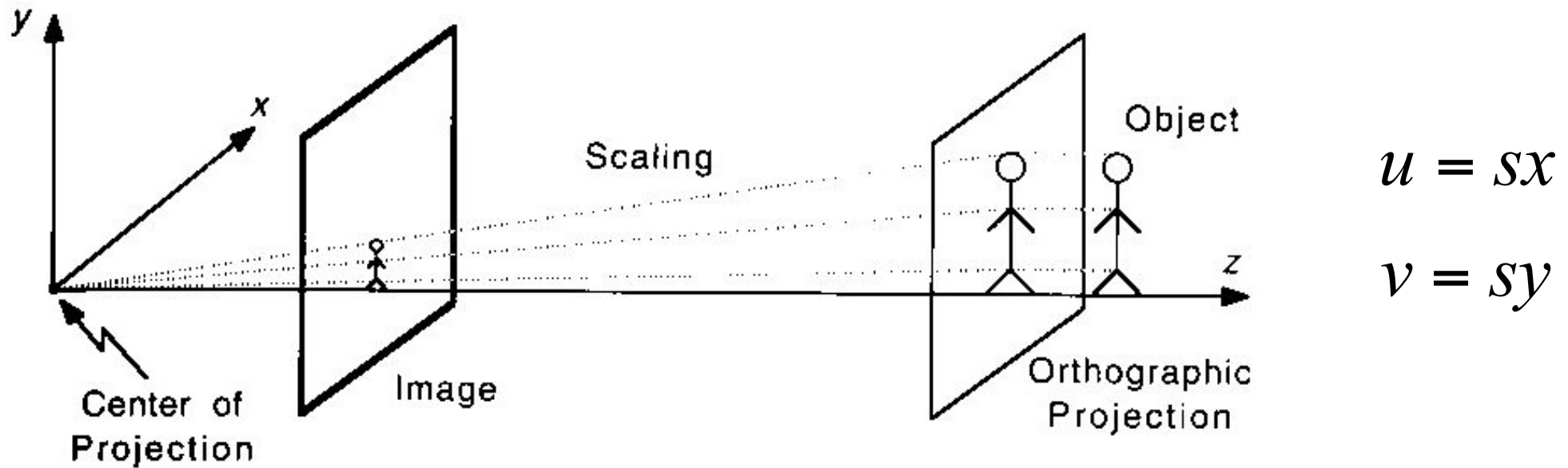

Special case of perspective projection:

- Large f
 - Objects close to the optical axis
- Parallel lines mapped into parallel lines.

Orthographic Projection

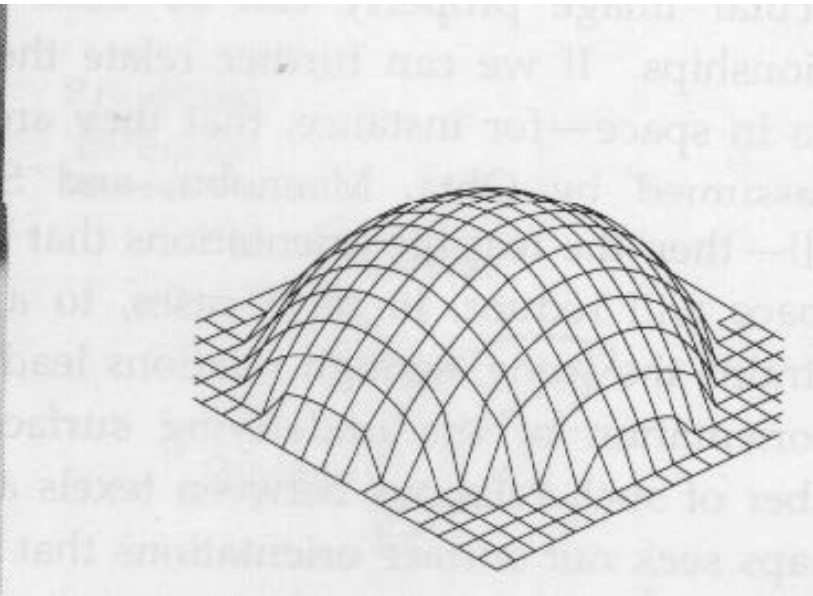
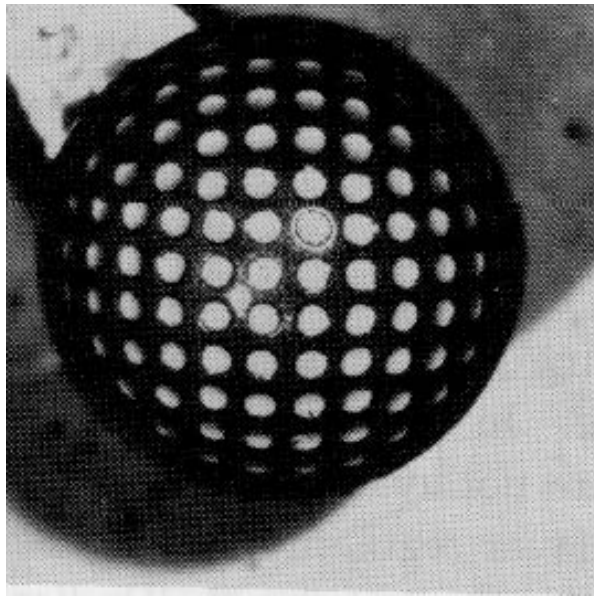
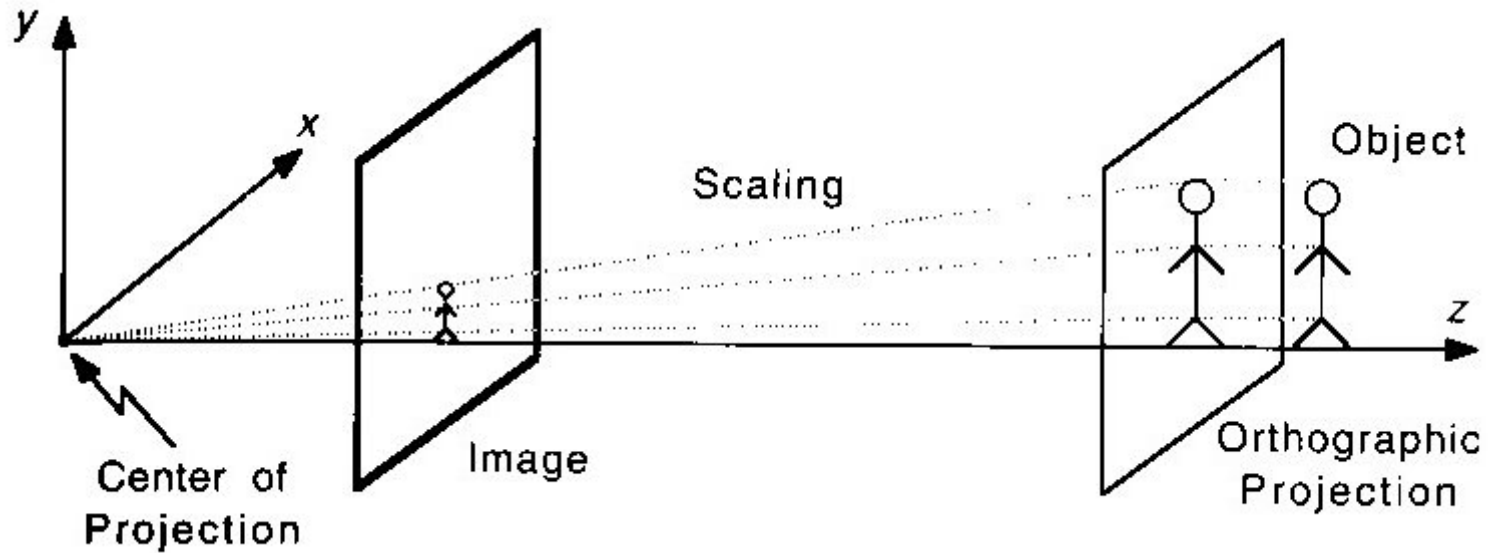

Tilt And Slant

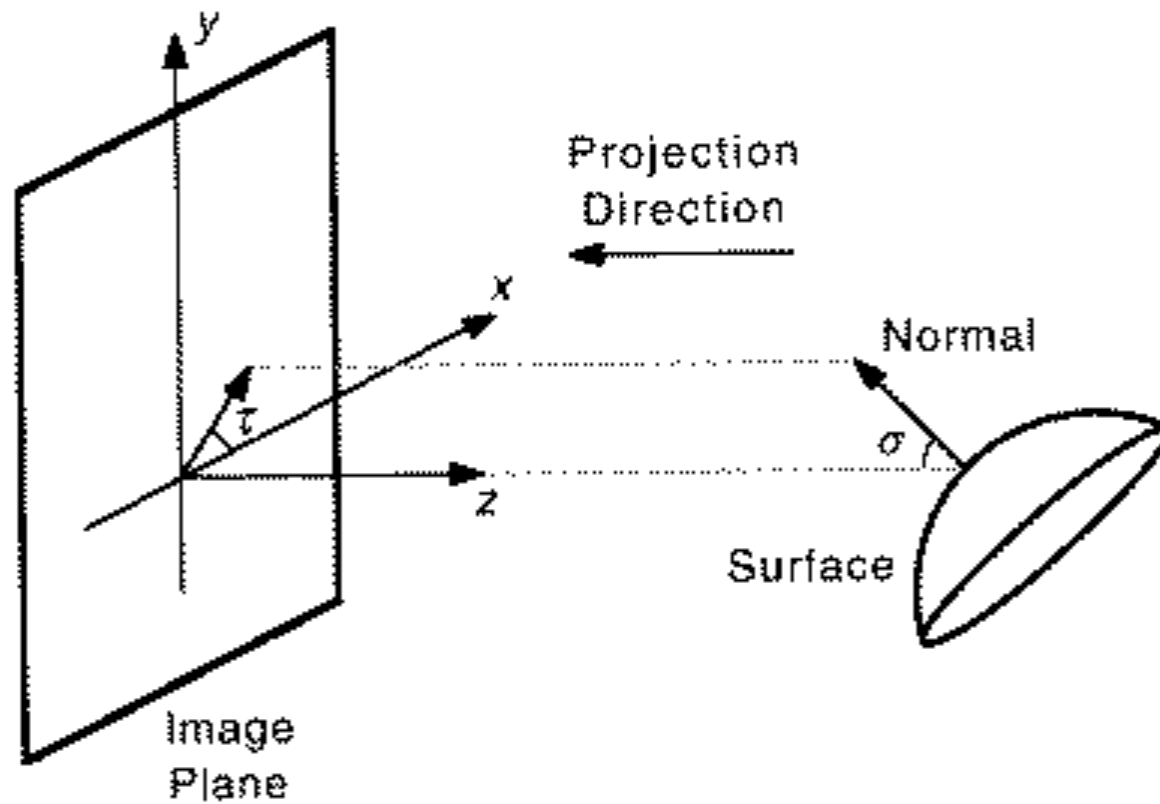

Orthographic Projection

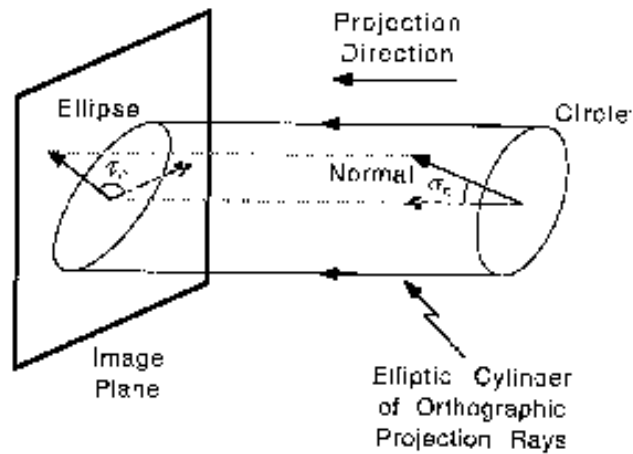

(a)

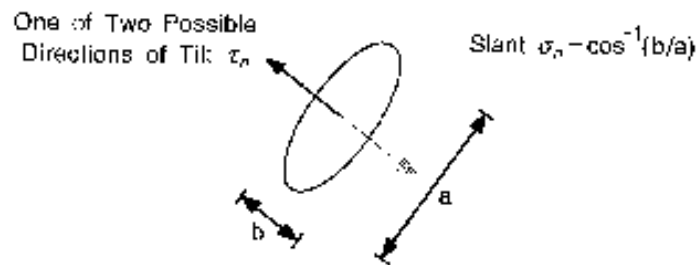

(b)

- **Tilt:** Derived from the image direction in which the surface element undergoes maximum compression.
- **Slant:** Derived from the extent of this compression.

Cheetah

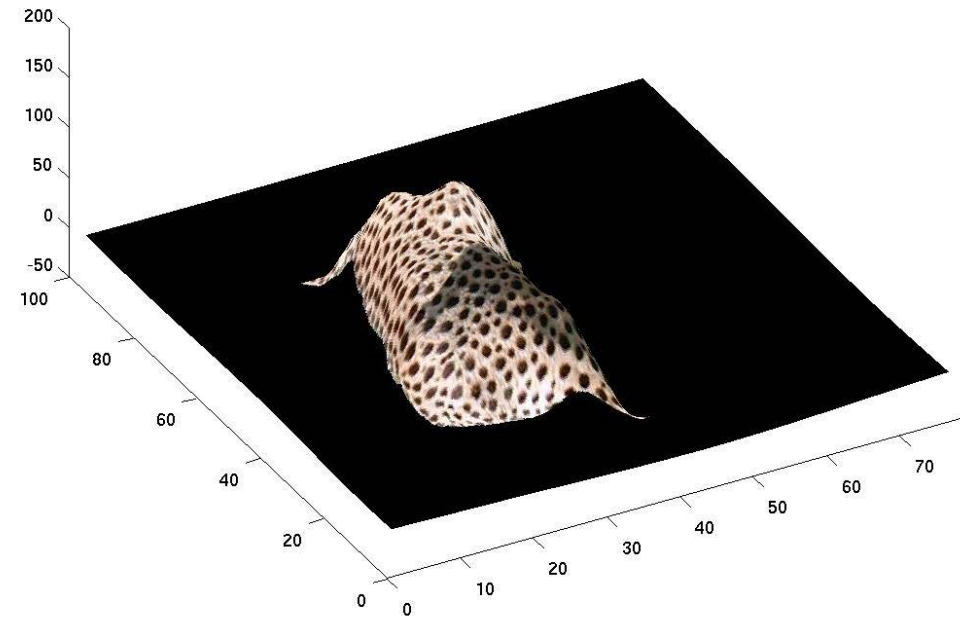
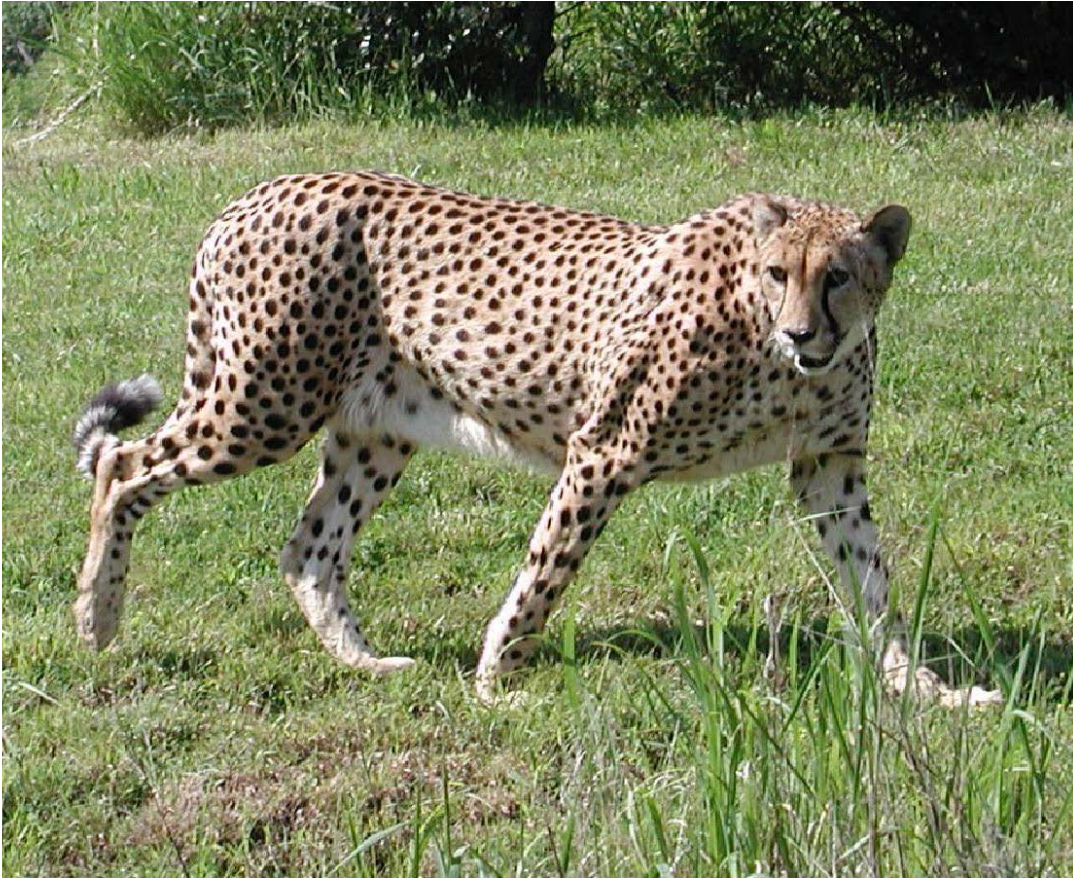

Perpendicular Lines

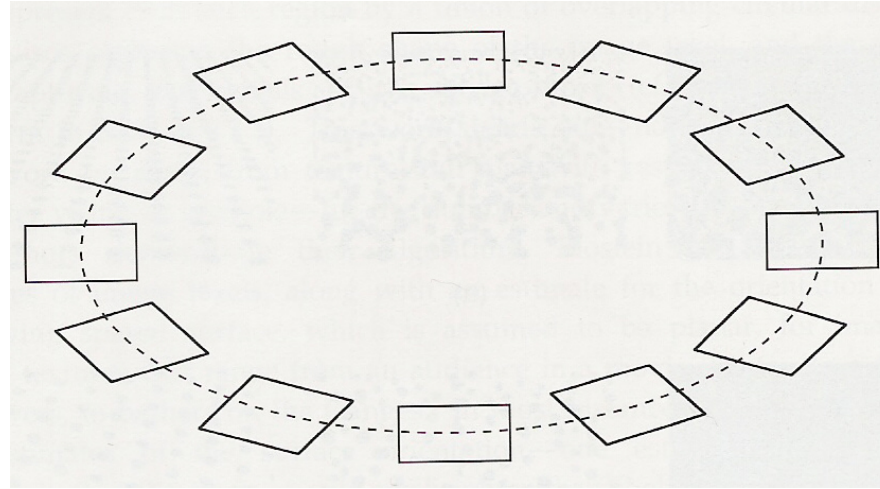

Orthographic projections of squares that are rotated with respect to each other in a plane inclined at $\omega=60^\circ$ to the image plane.

$$\frac{\|(\mathbf{p}_1 / l_1) \times (\mathbf{p}_2 / l_2)\|}{\|\mathbf{p}_1 / l_1\|^2 + \|\mathbf{p}_2 / l_2\|^2} = \frac{\cos(\omega)}{1 + \cos^2(\omega)}$$

Paraperspective Projection

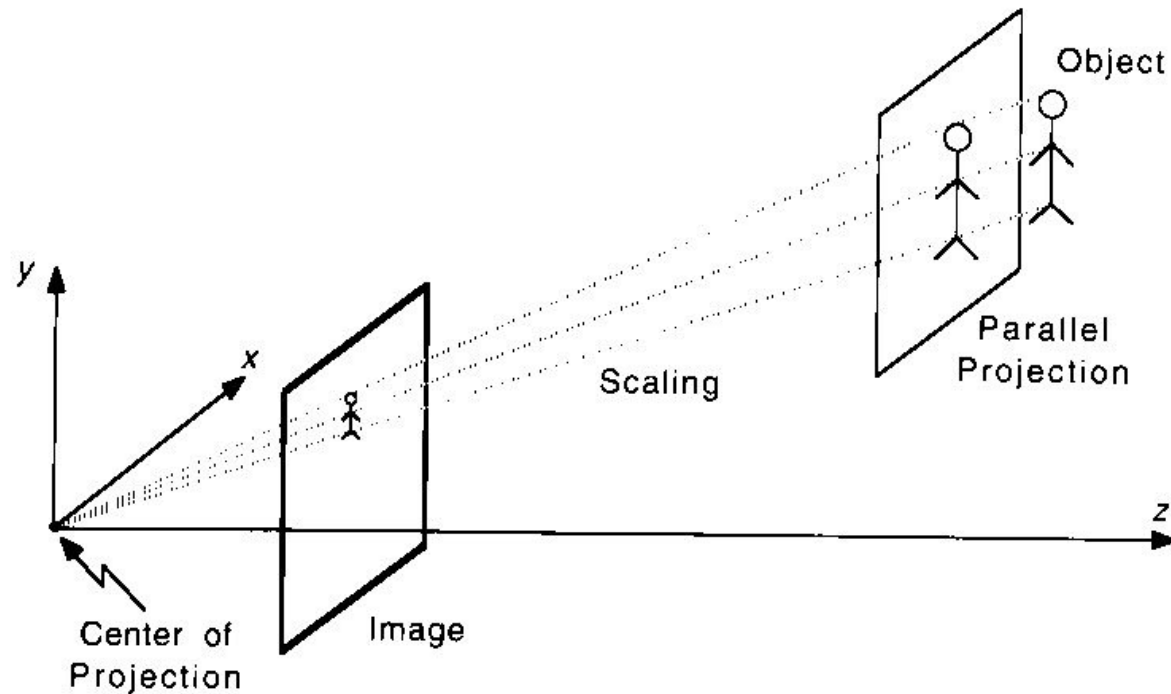

Generalization of the orthographic projection:

- Object dimensions small wrt distance to the center of projection.

→ Parallel projection followed by scaling

Paraperspective Projection

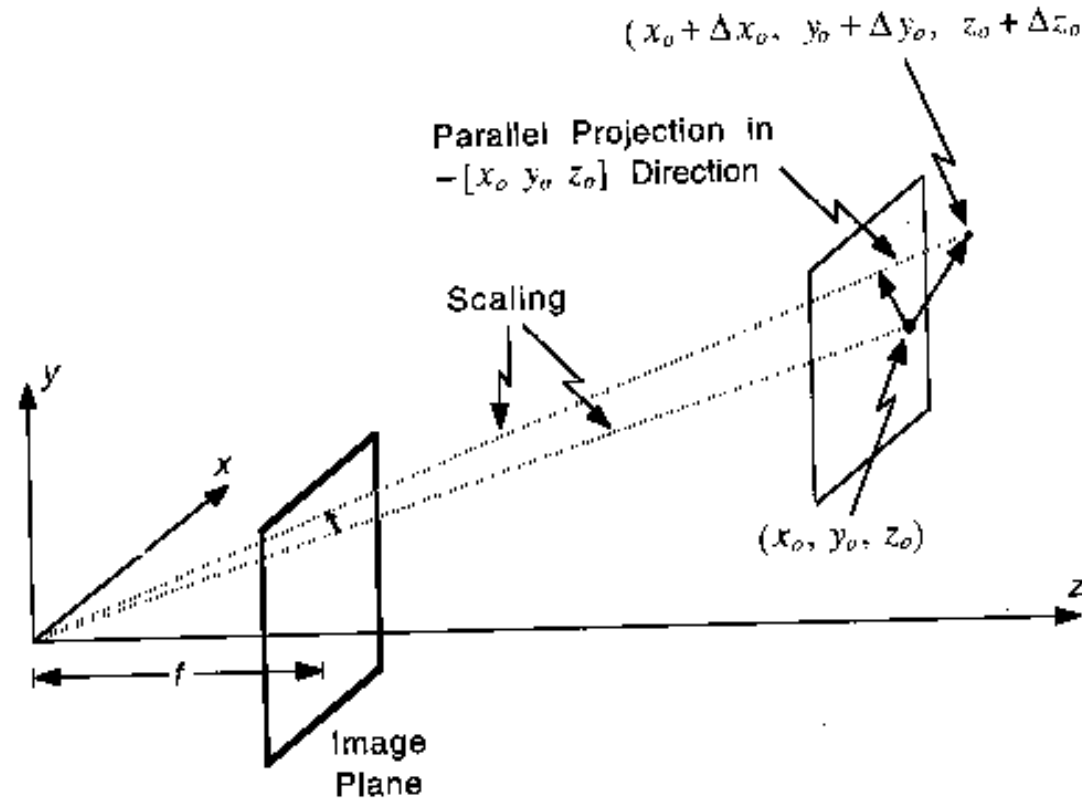

- For planar texels:

$$\text{Projected Area.} \rightarrow A' = -\frac{f^2}{z_0^3} \mathbf{n} \cdot [x_0 \ y_0 \ z_0] A \leftarrow \text{True Area.}$$

Unknown surface normal.

Parapespective Projection

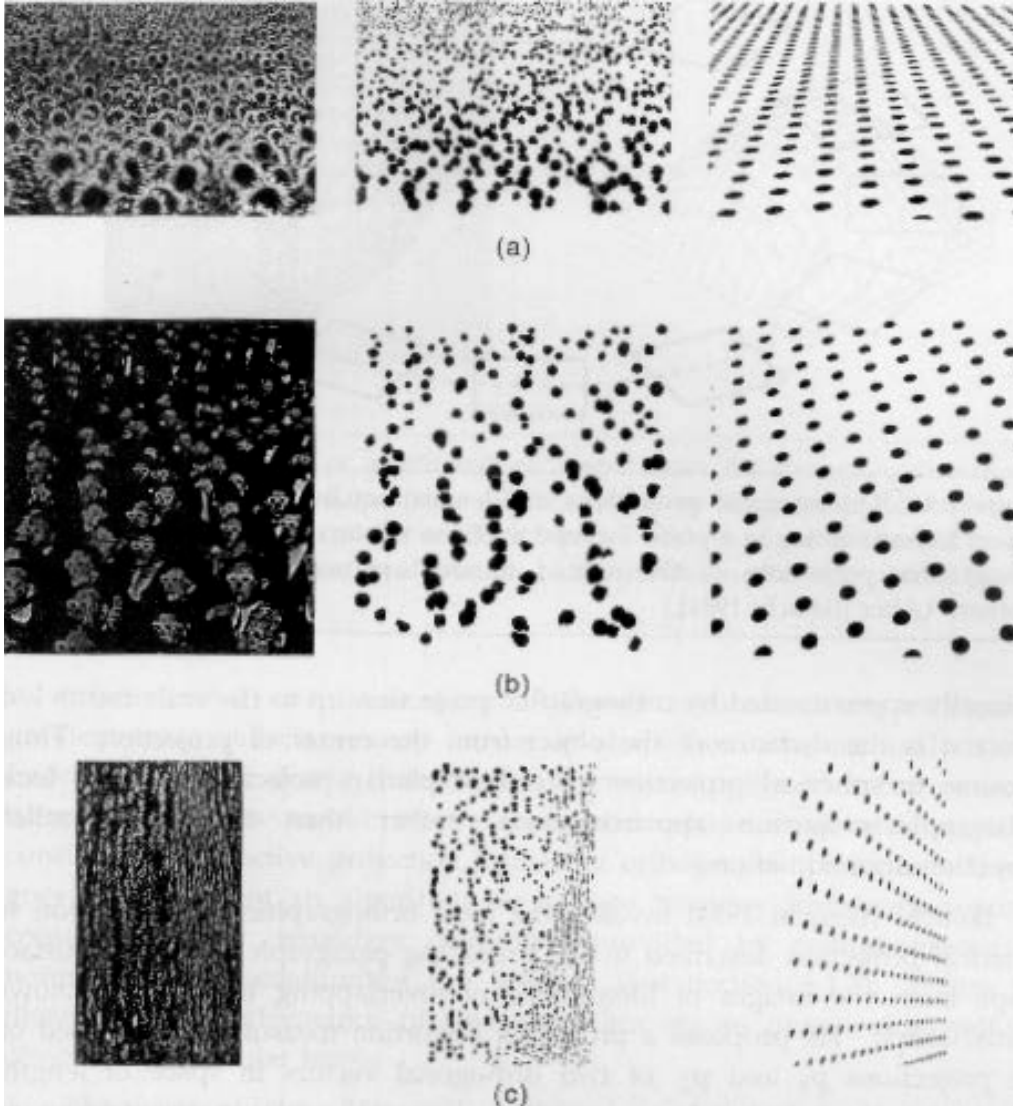

Texels:

- Image regions being brighter or darker than their surroundings.
- Assumed to have the same area in space.

→ Given enough texels, it becomes possible to estimate the normal.

Texture Gradient



Statistical Shape Recovery



Measure texture density as opposed to texel area, that is, the number of textural primitives per unit surface.

Assuming the texture to be homogeneous, we have:

$$\psi \mathbf{n} \propto \mathbf{b}$$

$$\psi = \begin{bmatrix} u_1 & v_1 & 1 \\ \dots & \dots & \dots \\ u_n & v_n & 1 \end{bmatrix}^t$$

$$\mathbf{b} = [b_1, \dots, b_n]^t$$

$$\Rightarrow \mathbf{n} = \frac{\psi \mathbf{n}}{\|\psi \mathbf{n}\|}$$

Unknown surface normal.

Image coordinates.

Function of density.

Deep Learning

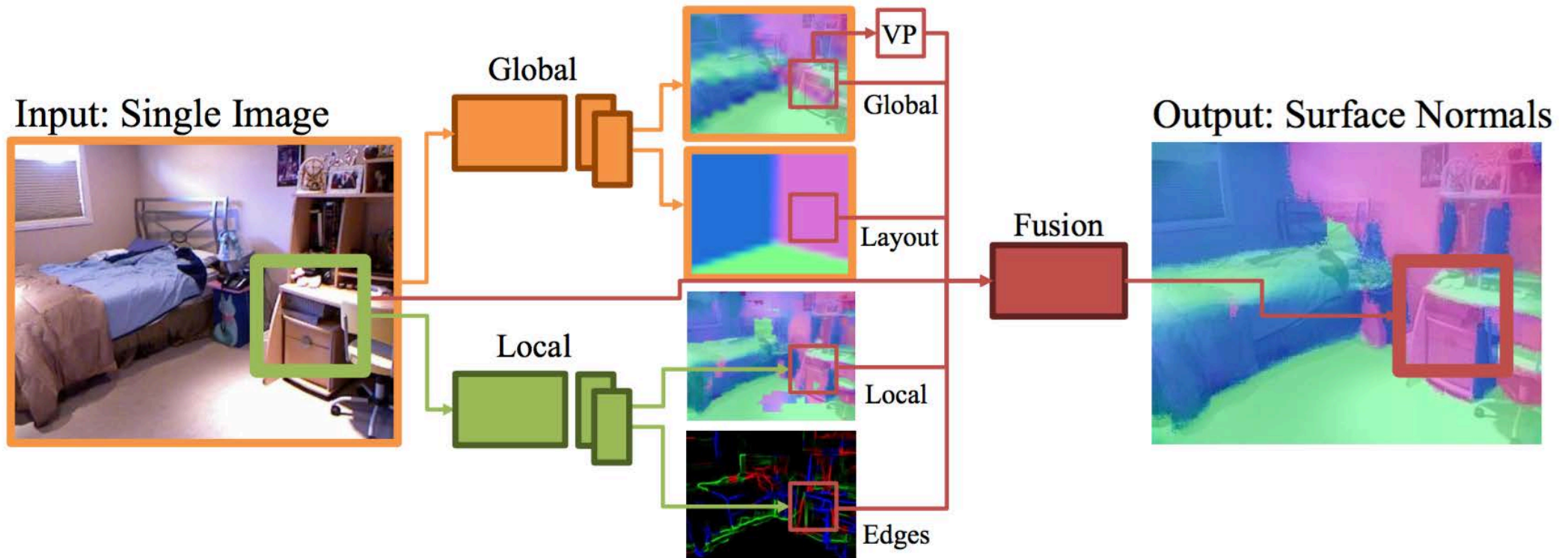

- Makes normal prediction possible even when the texture is not homogeneous.
- But only for the class of scenes it has been trained for.

Normals from a Single Image

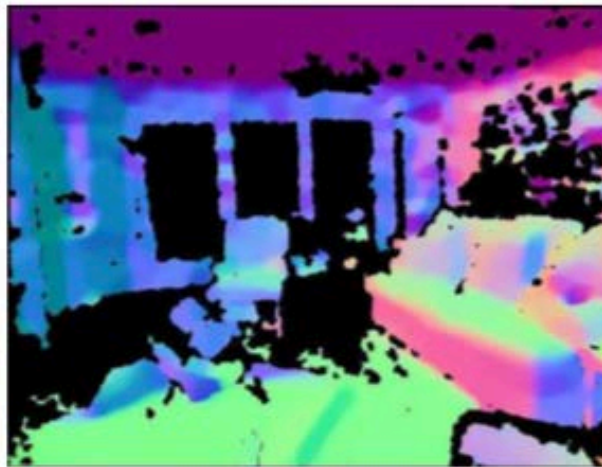
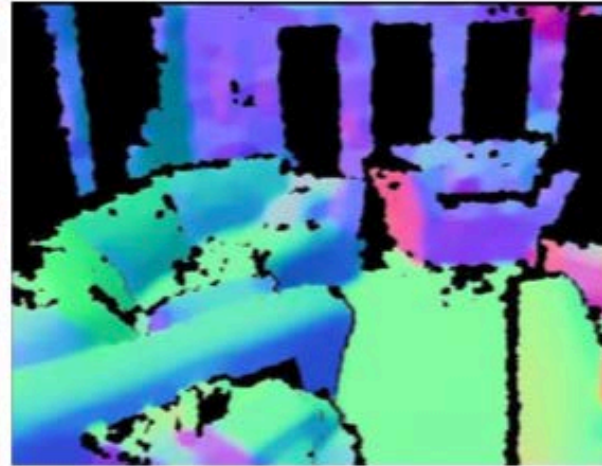

Input

Ground Truth

Output

Enforcing Task Consistency

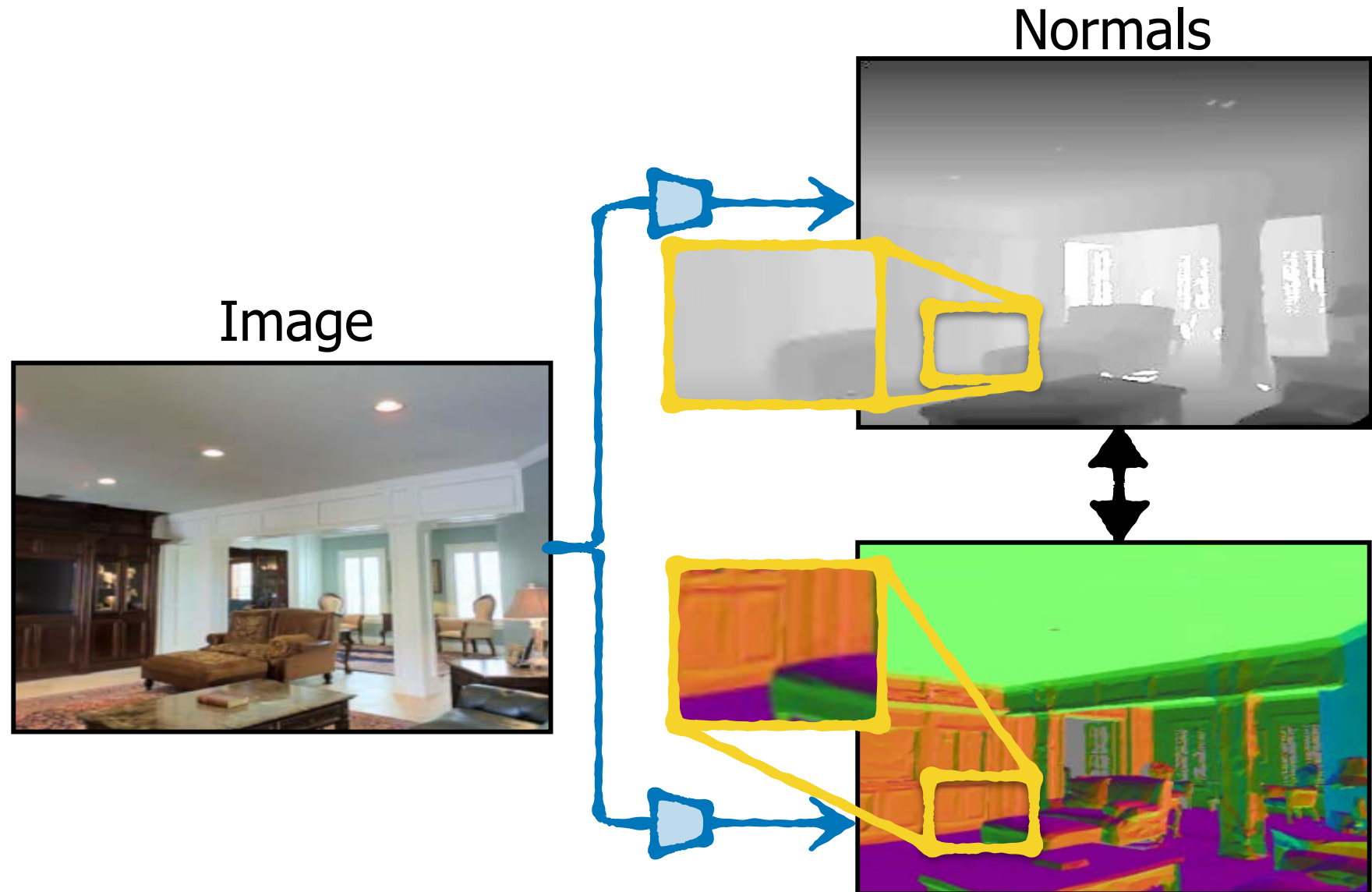

Forcing the deep net to be consistent across tasks increases robustness.

Segmentation

Strengths and Limitations

Strengths:

- Emulates an important human ability.

Limitations:

- Requires regular texture.
- Involves very strong assumptions.
- Deep learning can be used to weaken them.