

# Design Industriel A

## SHS 2020/21

Professeur: Tomas Kral  
Assistants: Matthieu Girel et Yann Mathys  
Mardi 15h15-17h00

Cut it,  
Bend it,  
Fold it.

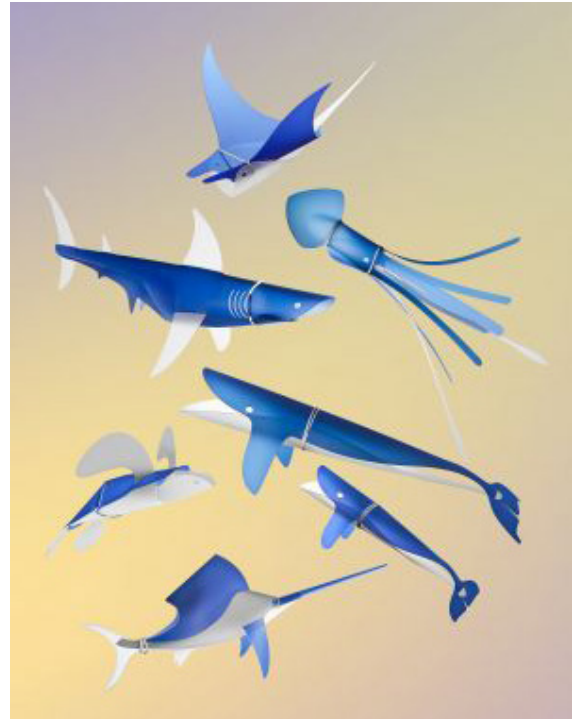

### OBJECTIF

Pour ce projet, il vous est demandé de créer un objet 3D à partir d'une feuille flexible de polypropylène. Cette matière vous sera fournie en quantité raisonnable par nos soins. (Pour les tests ainsi que pour le prototype final)

### METHODE

Vous êtes libre de choisir la fonction de l'objet que vous voulez dessiner, mais l'utilisation de cette matière doit être justifiée et doit jouer un rôle dans votre objet (pas uniquement décorative).

La majeure partie de votre objet doit être composée de cette matière. Vous pouvez tout de même ajouter d'autres matériaux, éléments, structures ou mécanismes si cela est nécessaire pour le fonctionnement de votre objet. Vous pouvez, par exemple, rajouter une douille et un câble électrique pour dessiner une lampe.

Less is more: avec peu de moyens et de la simplicité, vous devrez réaliser un objet intéressant avec toutes les qualités inhérentes à sa fonction. Jouez avec cette matière et essayez d'exploiter au maximum les caractéristiques et les possibilités qu'elle vous offre.

Le polypropylène a différentes qualités: flexibilité, bonne résistance au pliage (charnière vive), bonne diffusion de la lumière, facile à découper, difficile à déchirer, peut être assemblé de différentes manières (thermo-soudure, rivets, couture, velcro)...

Commençant par une phase de recherche, d'analyse et d'observation sous forme d'une série d'images de références, d'esquisses, de pré-maquettes et de tests, la première partie du semestre sera consacrée à trouver un concept, une approche personnelle et innovante par rapport à cette matière. La deuxième partie de semestre sera consacrée au développement de l'idée choisie sous forme de maquettes plus précises. La phase finale du projet sera dédiée à la mise au point des détails de construction et à la réalisation d'une maquette / prototype grandeur nature.

Ce travail est un projet en groupe de 3 étudiants.

### RESULTAT

Une maquette ou un prototype de votre objet à l'échelle 1:1 (si possible fonctionnel)

Une série de photos de votre objet en situation, un dessin technique de base et un carnet de recherches.

### CRITERES D'ÉVALUATION

Les critères d'évaluation seront: l'originalité du concept, la cohérence et la pertinence globale du projet ainsi que la qualité de la présentation finale.

# Polypropylène (PP)

## Feuilles disponibles



### 1. Feuilles translucides avec sablage

Dimension d'une feuilles: 1400 × 1000 mm

Épaisseurs disponibles: 0.5, 0.8 et 1.2 mm

### 2. Feuilles blanches opaques

Dimension d'une feuilles: 1400 × 1000 mm

Épaisseurs disponibles: 0.5, 0.8, 1.2 et 1.8 mm

### 3. Feuilles colorées opaques

Couleurs disponibles: Orange, Rose, Bleu, Jaune, Gris et Noir

Dimension d'une feuilles: 1100 × 650 mm

Épaisseurs disponibles: 0.8 mm

# Plan du cours



Date	Qui, Comment et Où	Que faire
15.09	Uniquement online. E-meeting à 15h15 sur: <a href="https://ecal.whereby.com/room-shs-ecal-di1">https://ecal.whereby.com/room-shs-ecal-di1</a>	Introduction.
22.09	Groupe A présent à Renens (EPFL+ECAL lab) Groupes B+C online rdv de 15h15 à 17h sur: <a href="https://ecal.whereby.com/room-shs-ecal-di1">https://ecal.whereby.com/room-shs-ecal-di1</a> ou <a href="https://ecal.whereby.com/room-shs-ecal-di2">https://ecal.whereby.com/room-shs-ecal-di2</a>	Lancement du sujet. Discussion et création de groupes de 3 étudiants pour le projet.
29.09	Groupe C présent à Renens (EPFL+ECAL lab) Groupes A+B online rdv de 15h15 à 17h sur: <a href="https://ecal.whereby.com/room-shs-ecal-di1">https://ecal.whereby.com/room-shs-ecal-di1</a> ou <a href="https://ecal.whereby.com/room-shs-ecal-di2">https://ecal.whereby.com/room-shs-ecal-di2</a>	Recherche documentée sur la matière, son utilisation, références personnelles et inspirations (pliage, fonctions d'objets, esthétique). Présentez au minimum 3 images (résultant de vos recherches documentaires) d'objets qui sont créés à partir d'une feuille 2D d'une quelconque matière et faites-en une critique (points positifs/négatifs). Présentez vos premières idées de projet.
06.10	Groupe B présent à Renens (EPFL+ECAL lab) Groupes A+C online rdv de 15h15 à 17h sur: <a href="https://ecal.whereby.com/room-shs-ecal-di1">https://ecal.whereby.com/room-shs-ecal-di1</a> ou <a href="https://ecal.whereby.com/room-shs-ecal-di2">https://ecal.whereby.com/room-shs-ecal-di2</a>	Discussions autour de premières pistes, idées et intentions. Premières esquisses.
13.10	Groupe A présent à Renens (EPFL+ECAL lab) Groupes B+C online rdv de 15h15 à 17h sur: <a href="https://ecal.whereby.com/room-shs-ecal-di1">https://ecal.whereby.com/room-shs-ecal-di1</a> ou <a href="https://ecal.whereby.com/room-shs-ecal-di2">https://ecal.whereby.com/room-shs-ecal-di2</a>	Approfondissement de 2 pistes (dessins et maquettes de base en papier / carton)

20.10	Groupe C présent à Renens (EPFL+ECAL lab) Groupes A+B online rdv de 15h15 à 17h sur: <a href="https://ecal.whereby.com/room-shs-ecal-di1">https://ecal.whereby.com/room-shs-ecal-di1</a> ou <a href="https://ecal.whereby.com/room-shs-ecal-di2">https://ecal.whereby.com/room-shs-ecal-di2</a>	Choix de la piste à poursuivre.
27.10	Groupe B présent à Renens (EPFL+ECAL lab) Groupes A+C online rdv de 15h15 à 17h sur: <a href="https://ecal.whereby.com/room-shs-ecal-di1">https://ecal.whereby.com/room-shs-ecal-di1</a> ou <a href="https://ecal.whereby.com/room-shs-ecal-di2">https://ecal.whereby.com/room-shs-ecal-di2</a>	Développement de la piste choisie (maquettes plus détaillées).
03.11	Groupe A présent à Renens (EPFL+ECAL lab) Groupes B+C online rdv de 15h15 à 17h sur: <a href="https://ecal.whereby.com/room-shs-ecal-di1">https://ecal.whereby.com/room-shs-ecal-di1</a> ou <a href="https://ecal.whereby.com/room-shs-ecal-di2">https://ecal.whereby.com/room-shs-ecal-di2</a>	Rendu intermédiaire. Maquette et dossier pdf.
10.11	Groupe C présent à Renens (EPFL+ECAL lab) Groupes A+B online rdv de 15h15 à 17h sur: <a href="https://ecal.whereby.com/room-shs-ecal-di1">https://ecal.whereby.com/room-shs-ecal-di1</a> ou <a href="https://ecal.whereby.com/room-shs-ecal-di2">https://ecal.whereby.com/room-shs-ecal-di2</a>	Développement selon feedback.
17.11	Groupe B présent à Renens (EPFL+ECAL lab) Groupes A+C online rdv de 15h15 à 17h sur: <a href="https://ecal.whereby.com/room-shs-ecal-di1">https://ecal.whereby.com/room-shs-ecal-di1</a> ou <a href="https://ecal.whereby.com/room-shs-ecal-di2">https://ecal.whereby.com/room-shs-ecal-di2</a>	Développement en maquettes.
24.11	Groupe A présent à Renens (EPFL+ECAL lab) Groupes B+C online rdv de 15h15 à 17h sur: <a href="https://ecal.whereby.com/room-shs-ecal-di1">https://ecal.whereby.com/room-shs-ecal-di1</a> ou <a href="https://ecal.whereby.com/room-shs-ecal-di2">https://ecal.whereby.com/room-shs-ecal-di2</a>	Réalisation du prototype final.
01.12	Groupe C présent à Renens (EPFL+ECAL lab) Groupes A+B online rdv de 15h15 à 17h sur: <a href="https://ecal.whereby.com/room-shs-ecal-di1">https://ecal.whereby.com/room-shs-ecal-di1</a> ou <a href="https://ecal.whereby.com/room-shs-ecal-di2">https://ecal.whereby.com/room-shs-ecal-di2</a>	Réalisation du prototype final.
08.12	Groupe B présent à Renens (EPFL+ECAL lab) Groupes A+C online rdv de 15h15 à 17h sur: <a href="https://ecal.whereby.com/room-shs-ecal-di1">https://ecal.whereby.com/room-shs-ecal-di1</a> ou <a href="https://ecal.whereby.com/room-shs-ecal-di2">https://ecal.whereby.com/room-shs-ecal-di2</a>	Travail sur la présentation du projet (photos, dessins techniques...)
15.12	Travail final déposée à l'EPFL+ECAL lab selon instructions.	Evaluation finale du semestre. (Prototype, photos de l'objet en situation, plans imprimés et documentation technique.)

Exemples de principes de la mise en forme de la feuille de polypropylène.

Pliage.

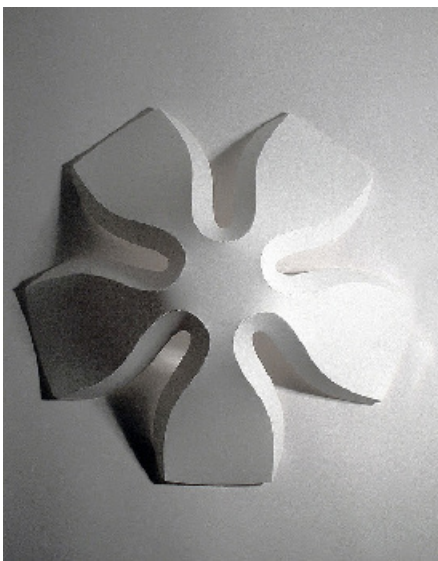

Pliage.

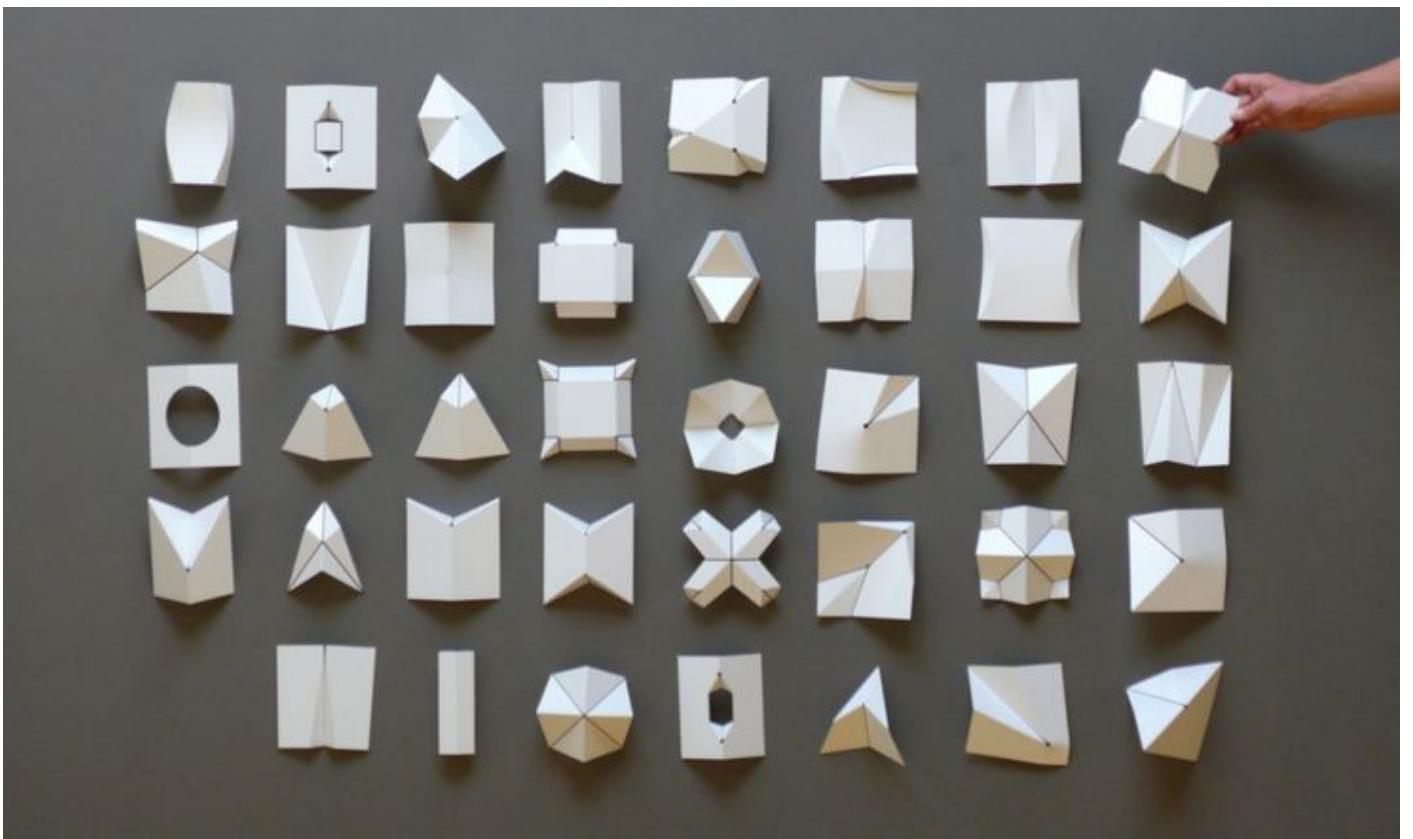

Pliage. Gaufrage. Marquage.





Découpe. Perforation.

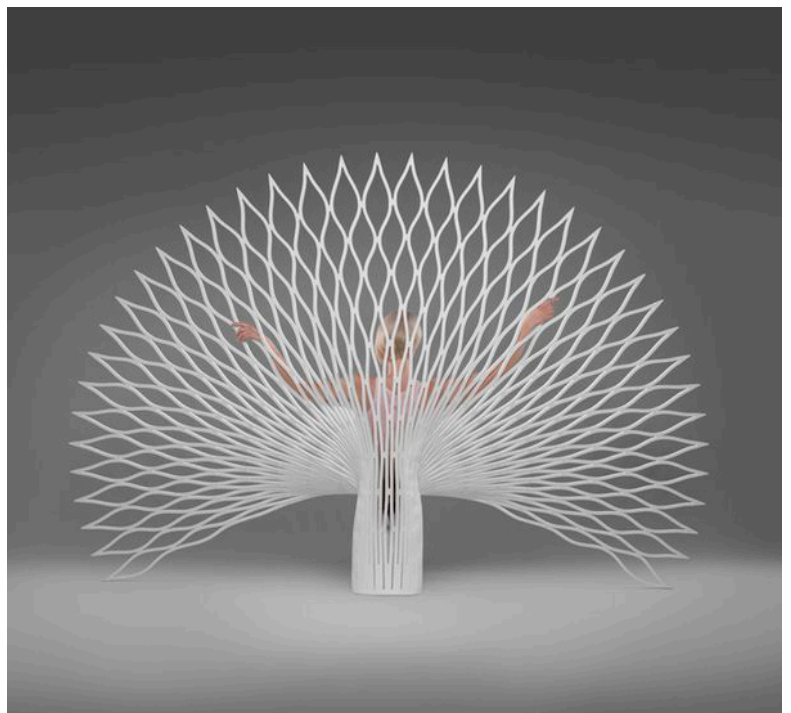
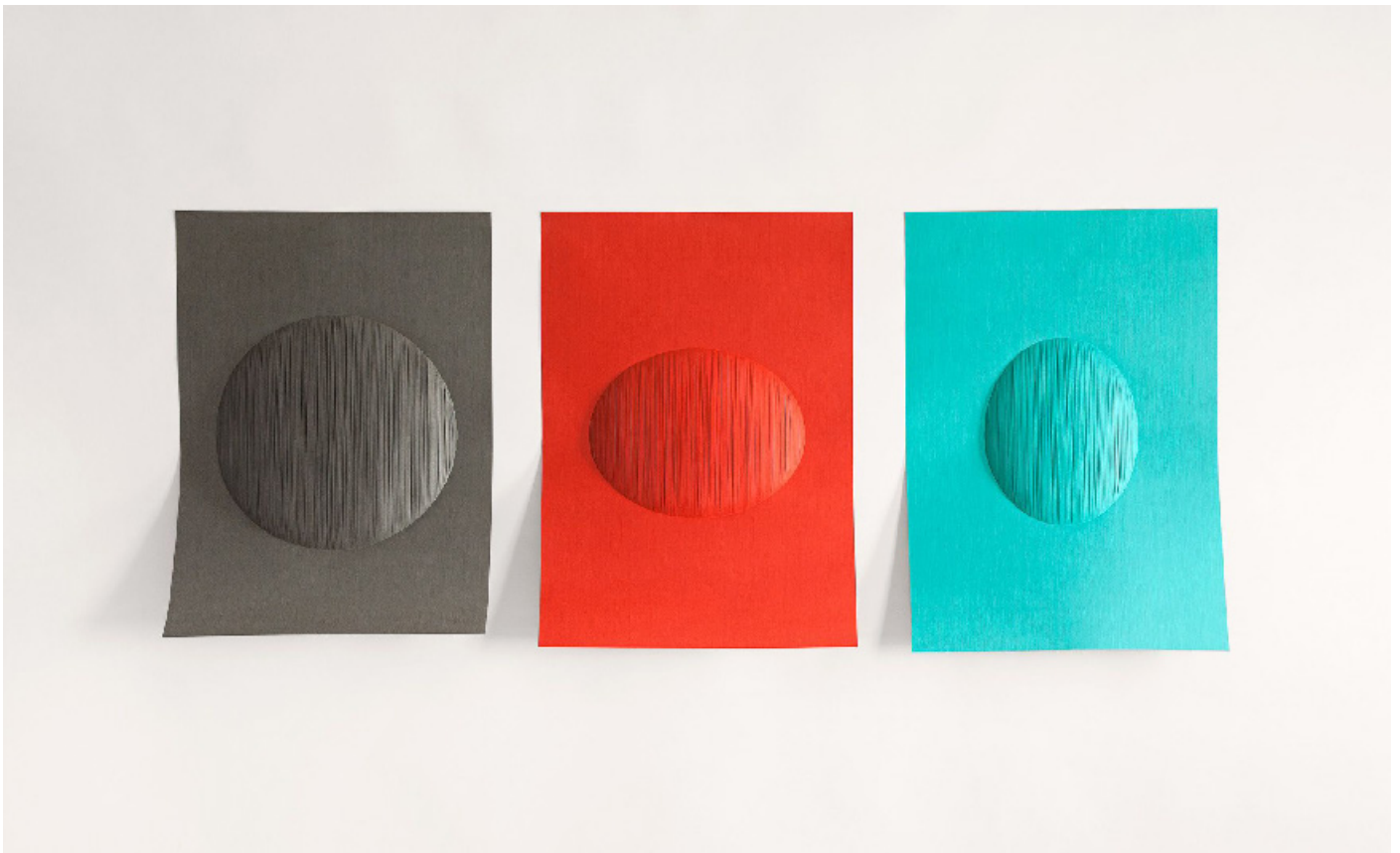

Pliage.  
Relief. Volume.

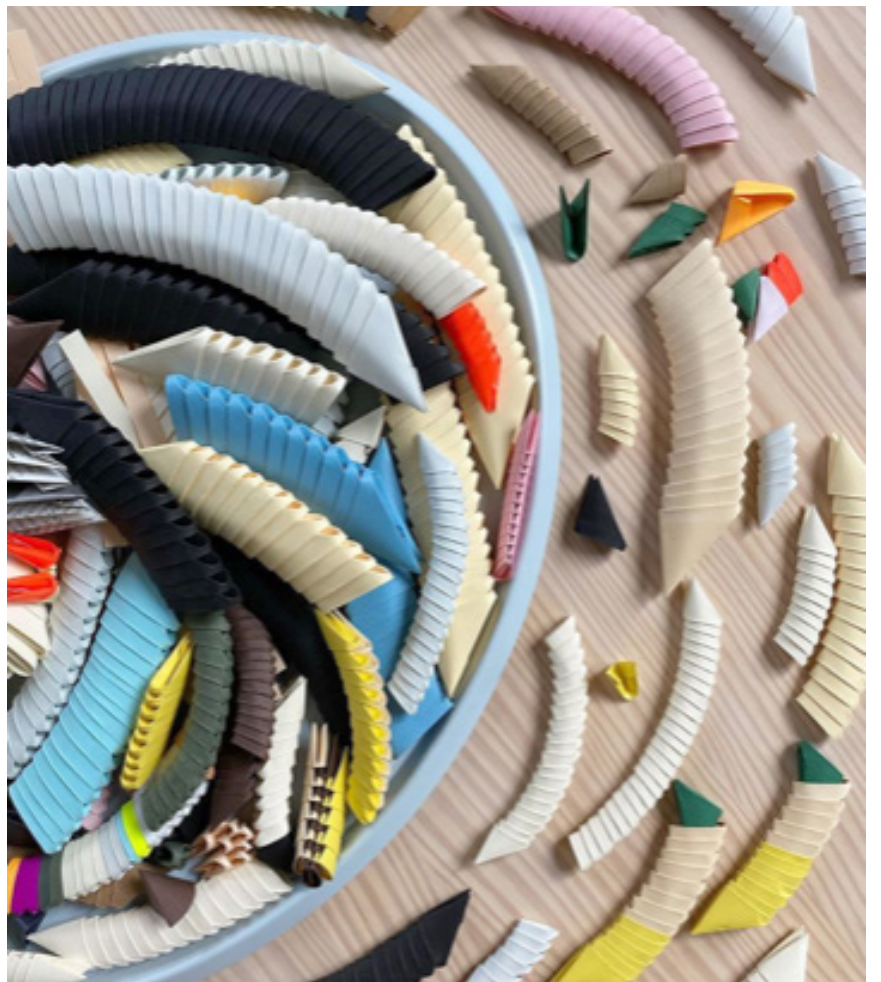
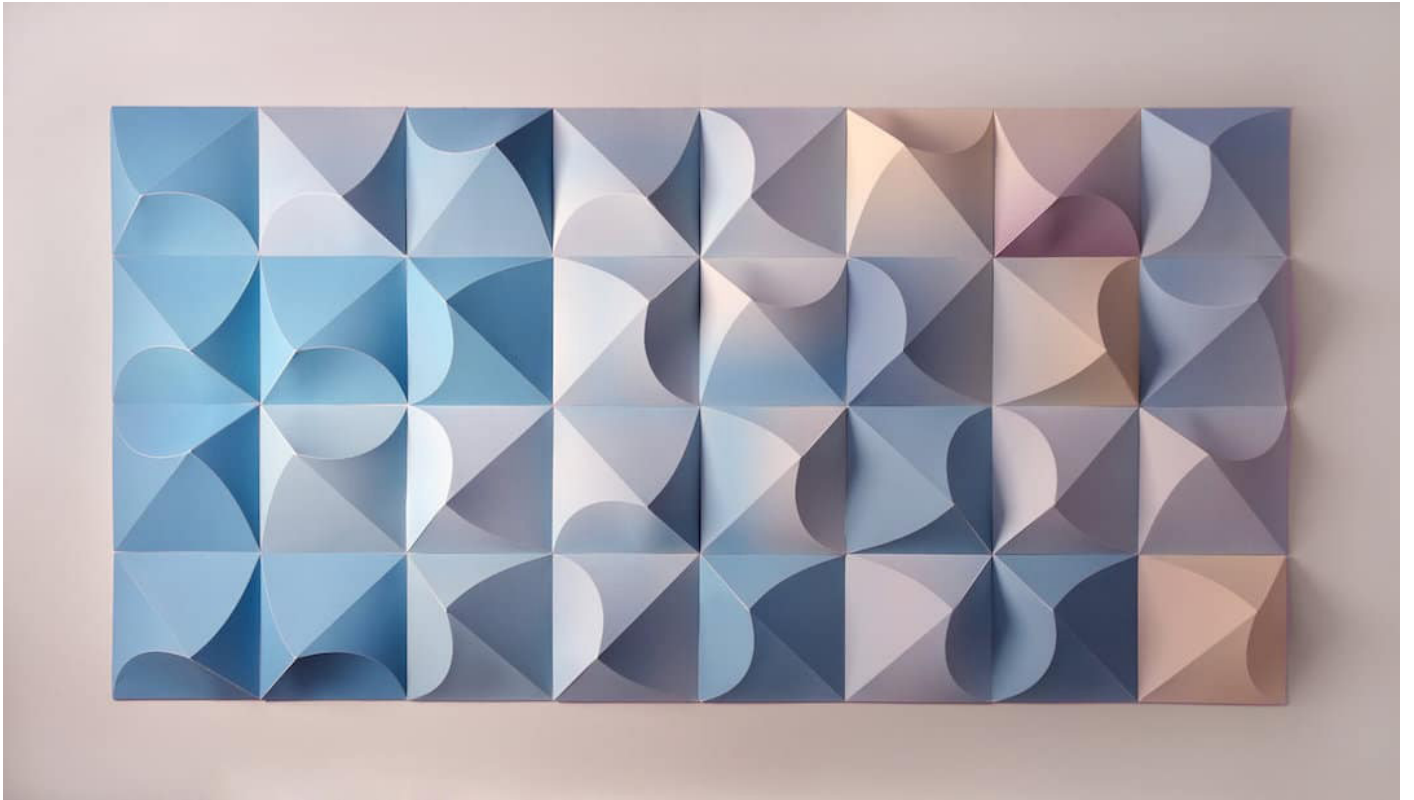

Rigidifier par le pli.



Pliage. Flat-pack.



Pliage. Flat-pack. Rigidifier. Attacher.



Pliage. Flat-pack. Rigidifier. Attacher.

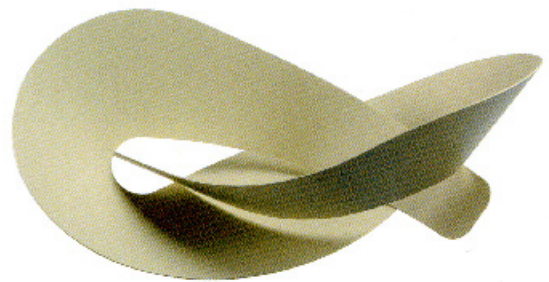
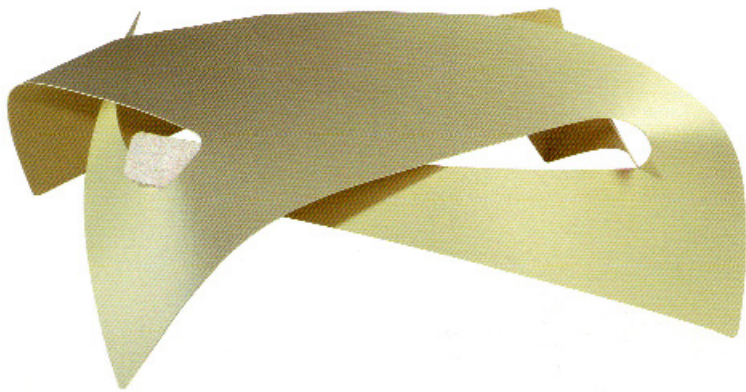
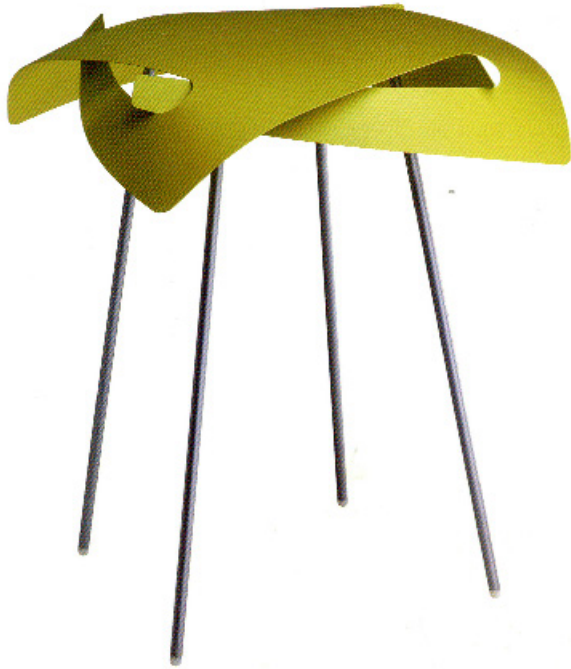

Détails. Découpe.

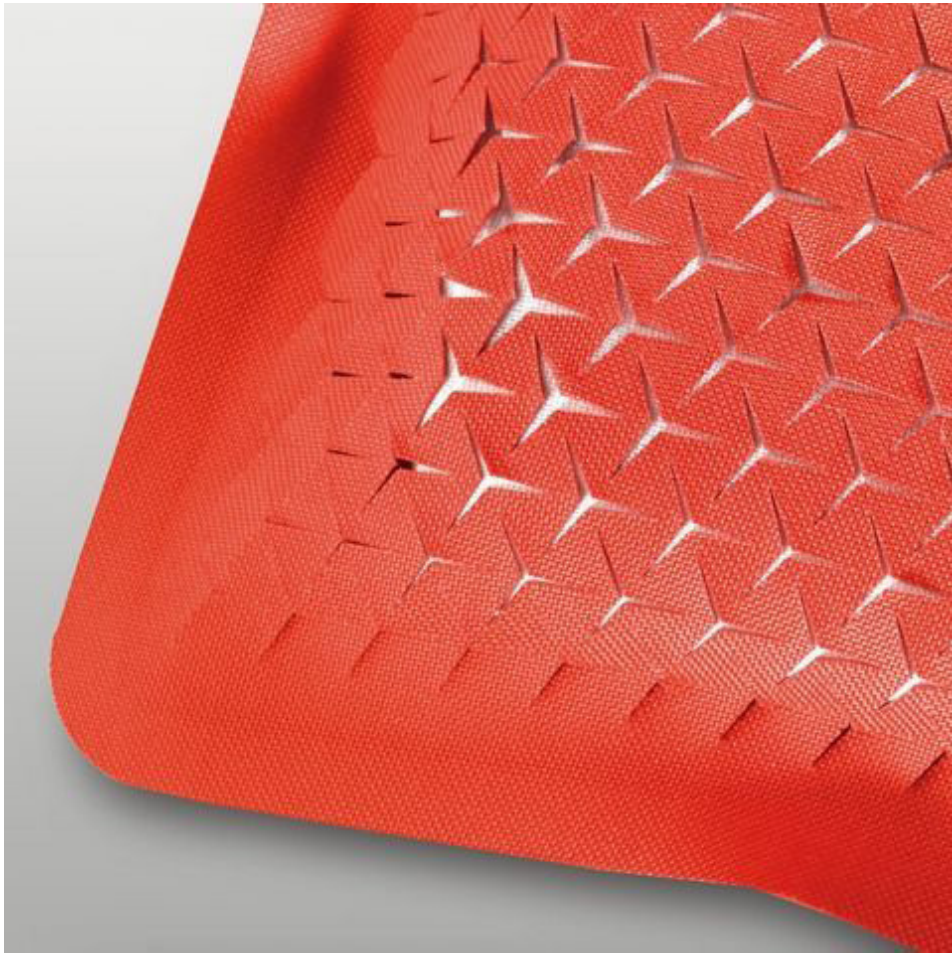

Exemples de possibles fonctions et types d'objets à développer.



Sac.



Sac.



Sac. Panier, Contenants.

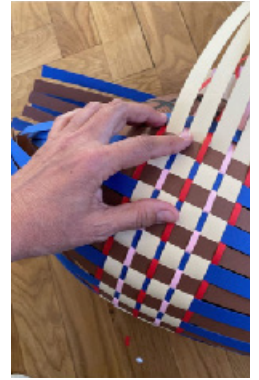
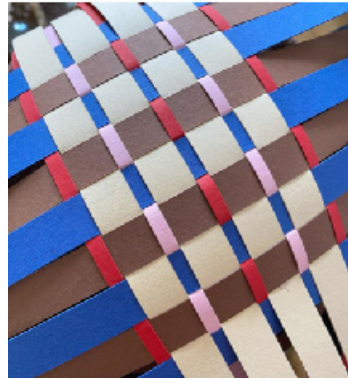

Sac. Panier, Contenants.



Paravent. Séparation Spatiale. Jeu avec la lumière.



Paravent. Séparation Spatiale. Jeu avec la lumière.

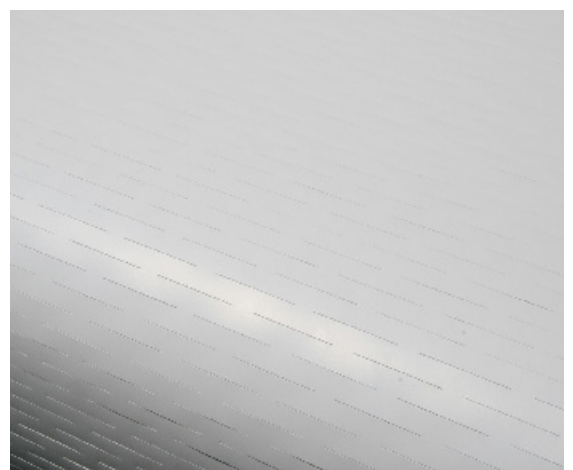
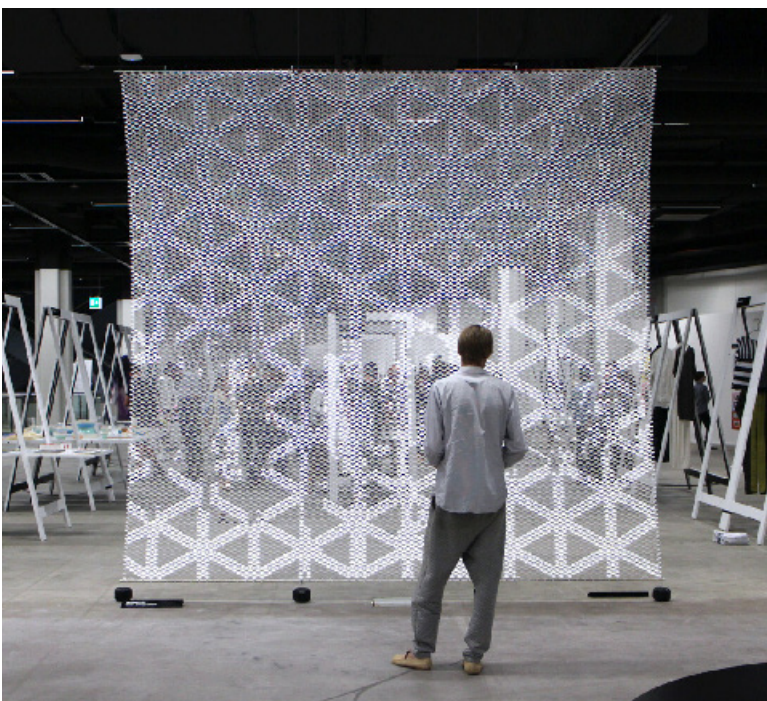
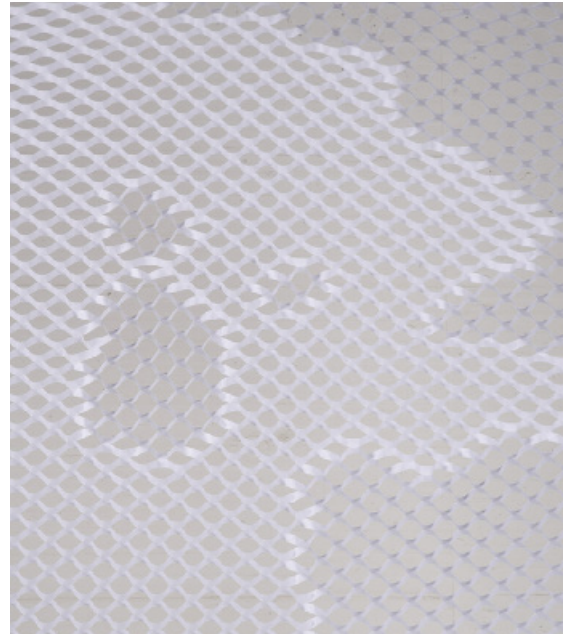

Paravent. Séparation Spatiale. Jeu avec la lumière.

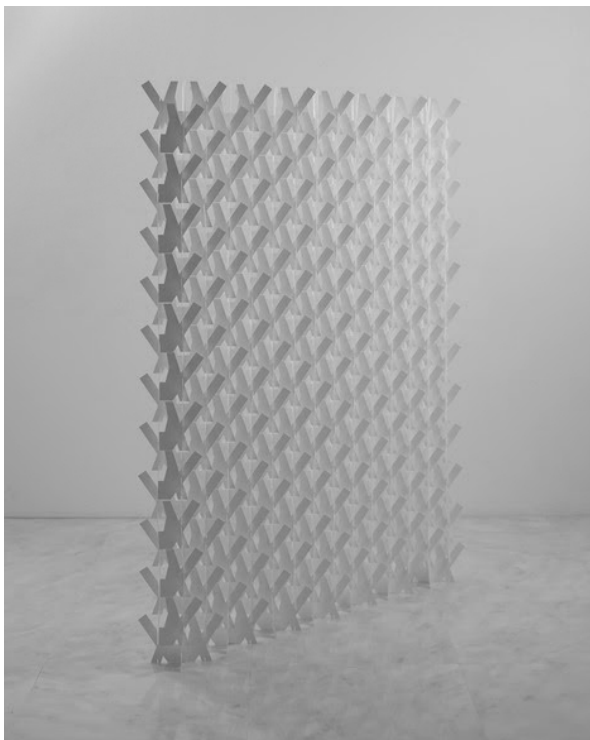
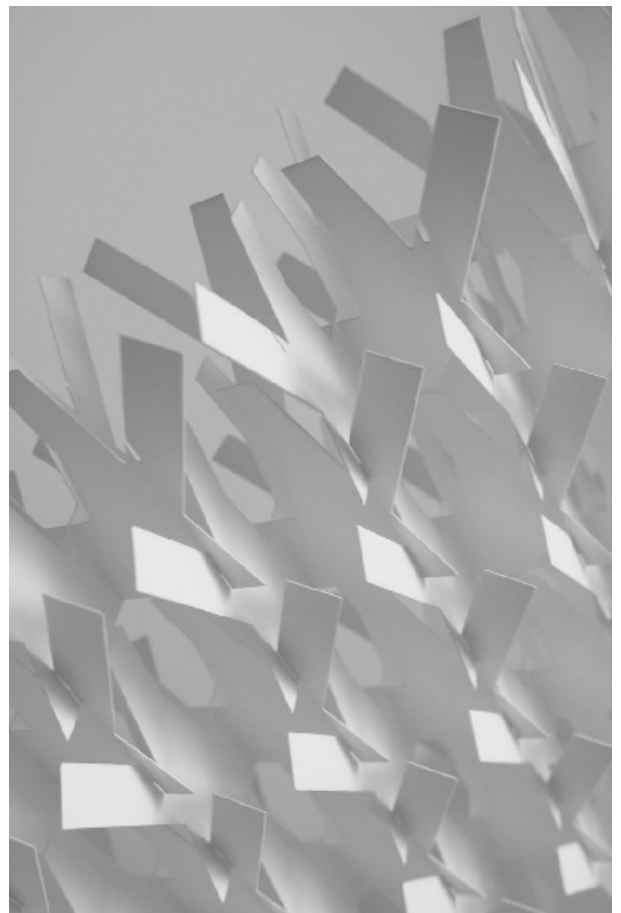
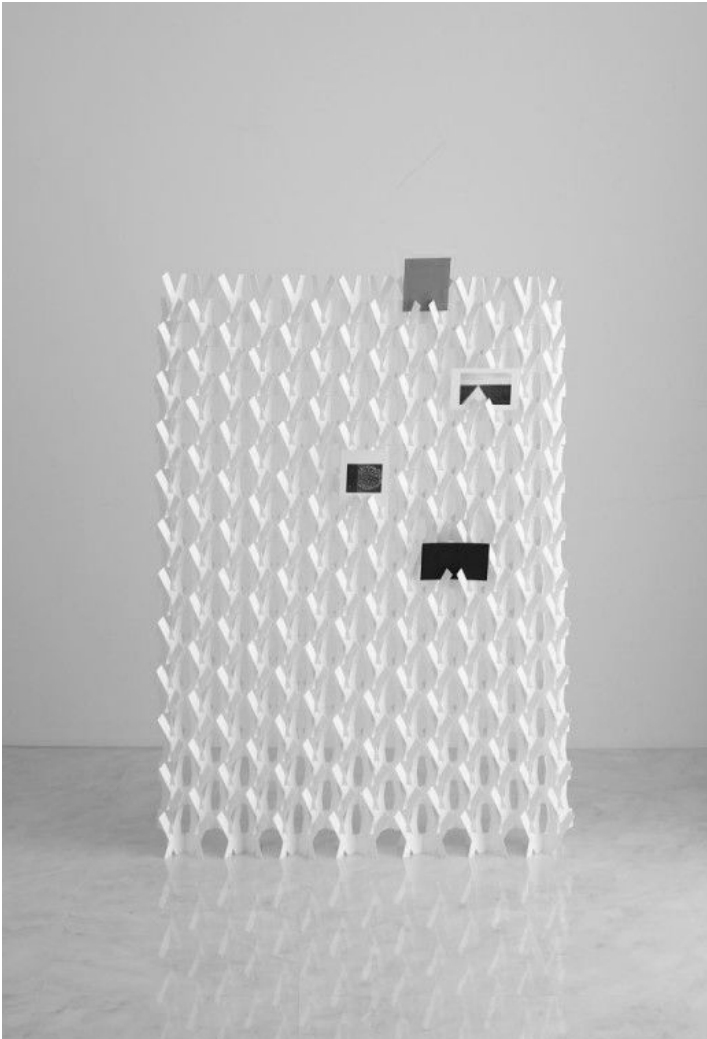

Lampe. Translucide.





Lampe. Translucide.



Lampe. Translucide.



Lampe.



Boite. Accessoires de bureau. Packaging.

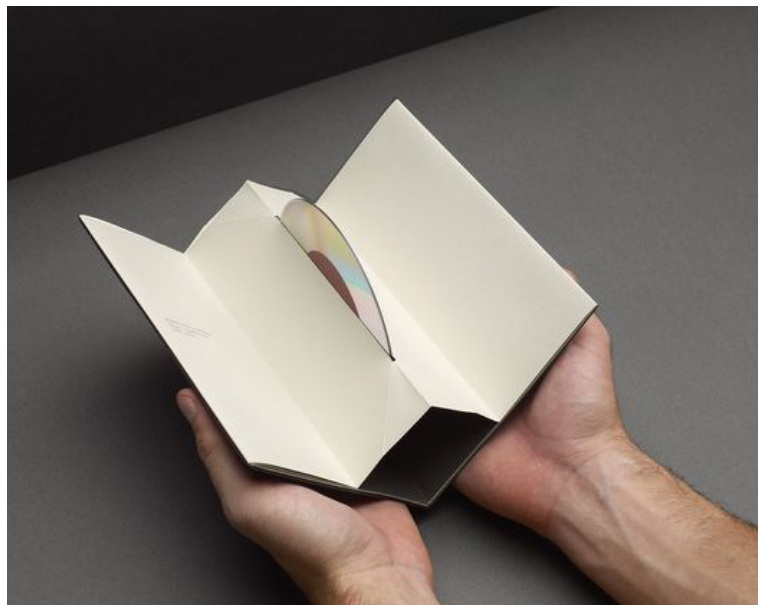

Accessoires de bureau.



Accessoires de bureau.



Accessoires de bureau.

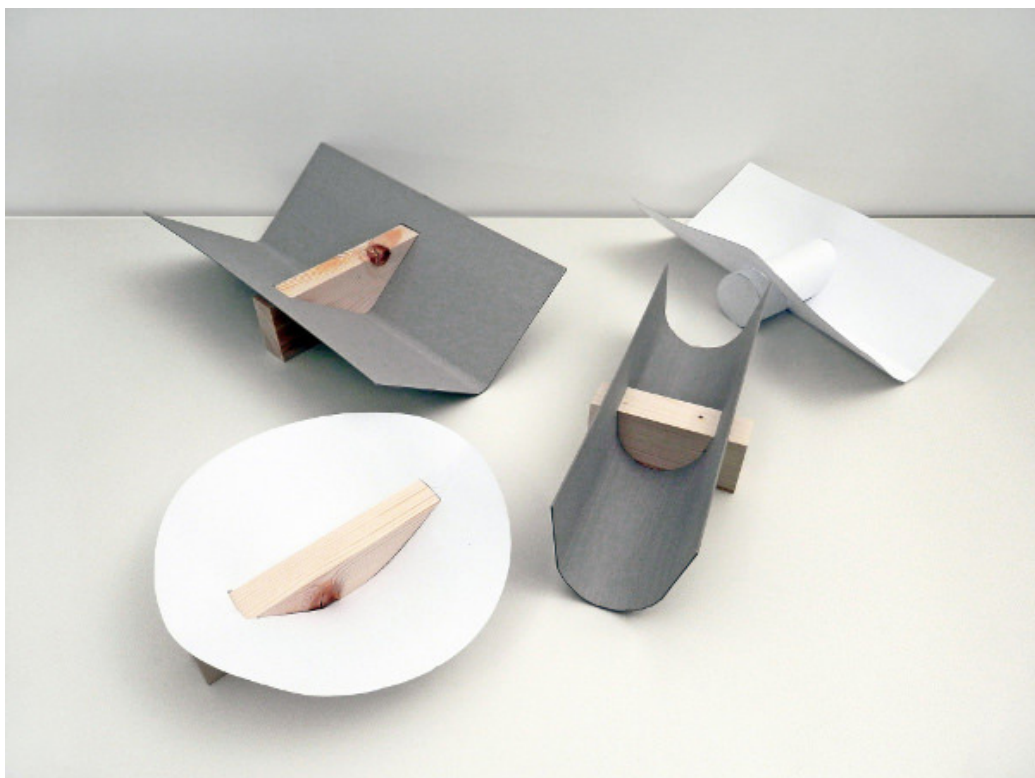

# Rangement.

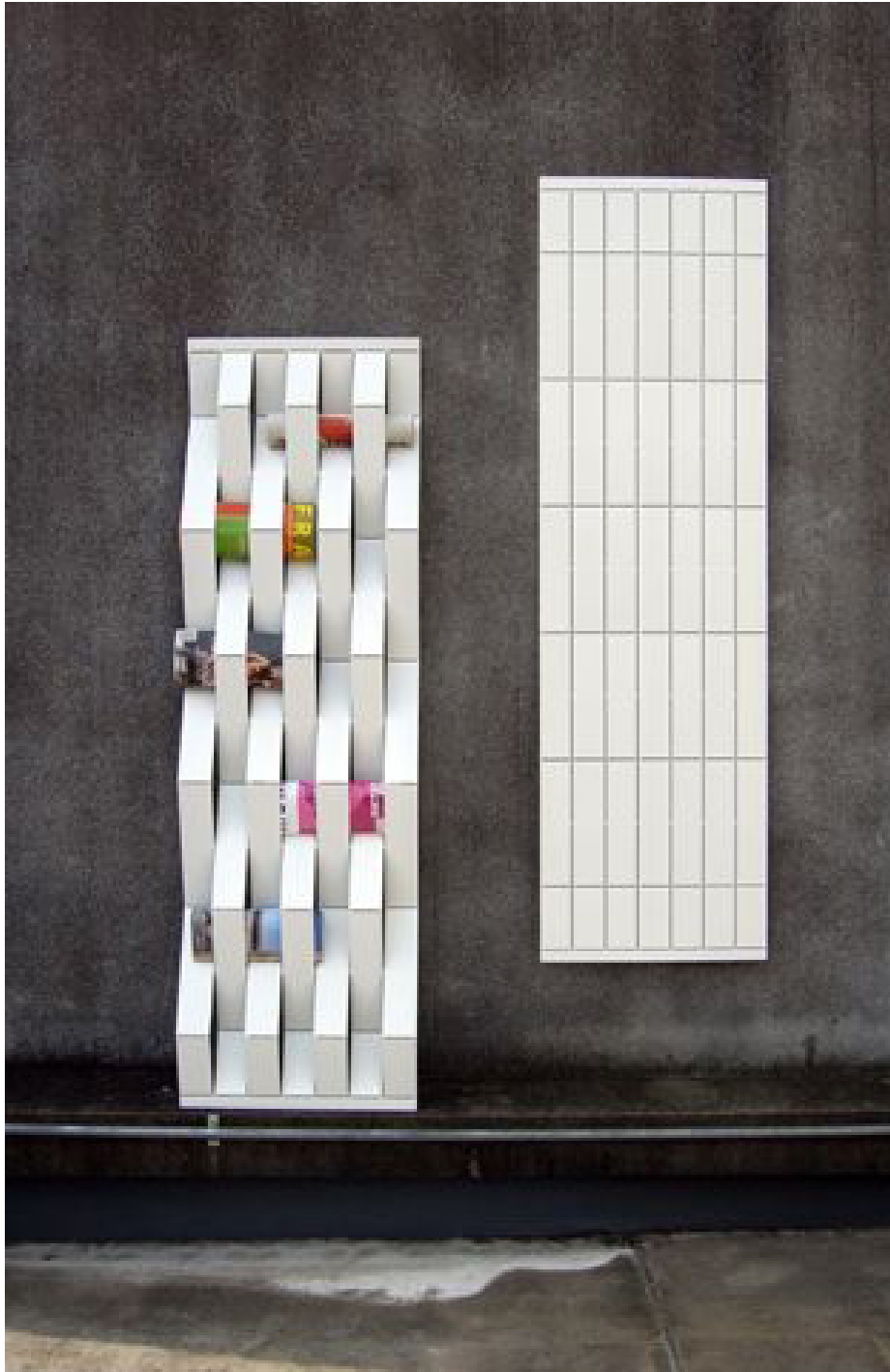



Jouets.



Jouets.  
Association avec d'autres matériaux.



Jouets.  
Association avec d'autres matériaux.  
Do it yourself.

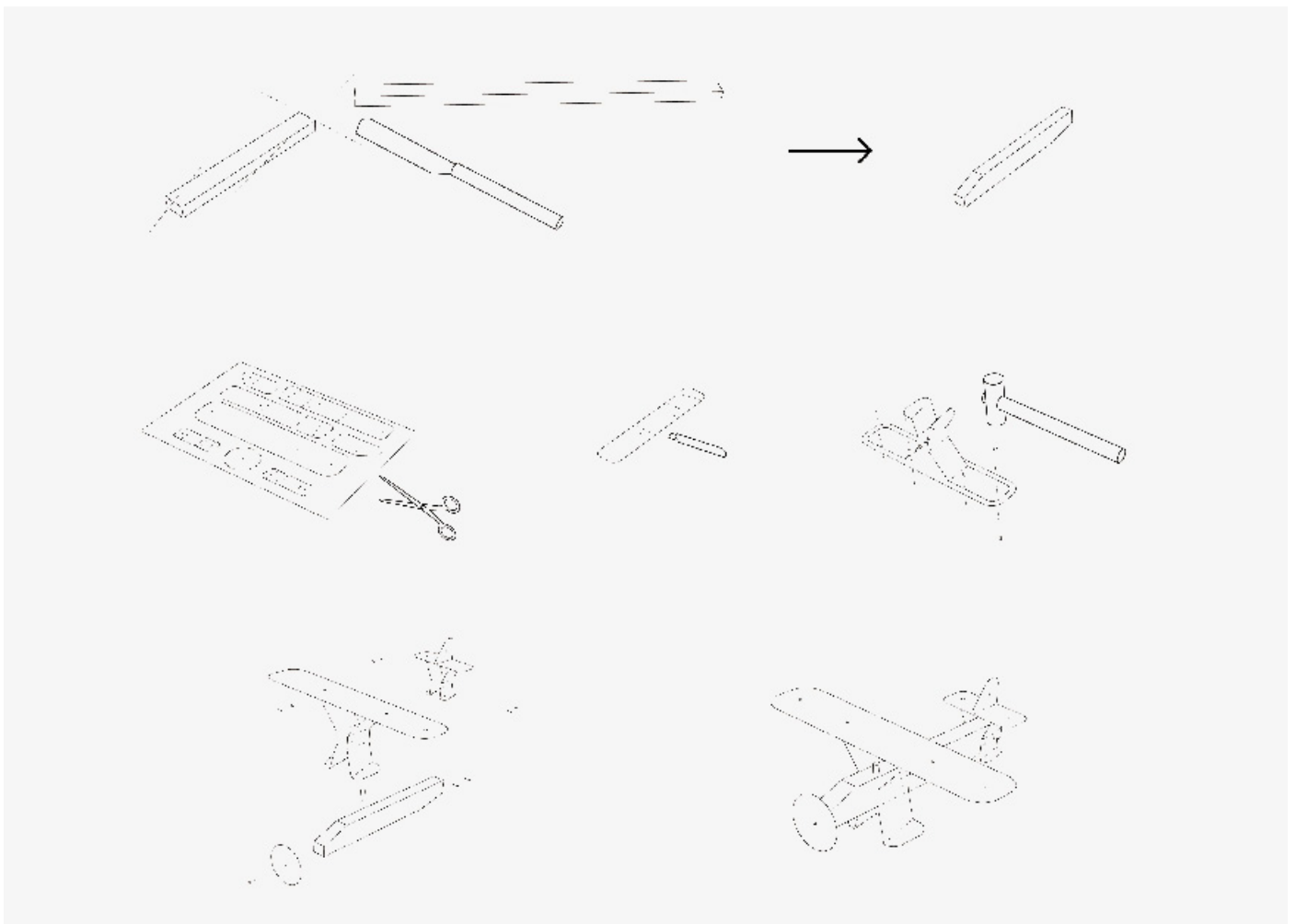

Contenants. Cuisine. Mini-serre.



Divers. Radio, horloge, étiquette de bagage...

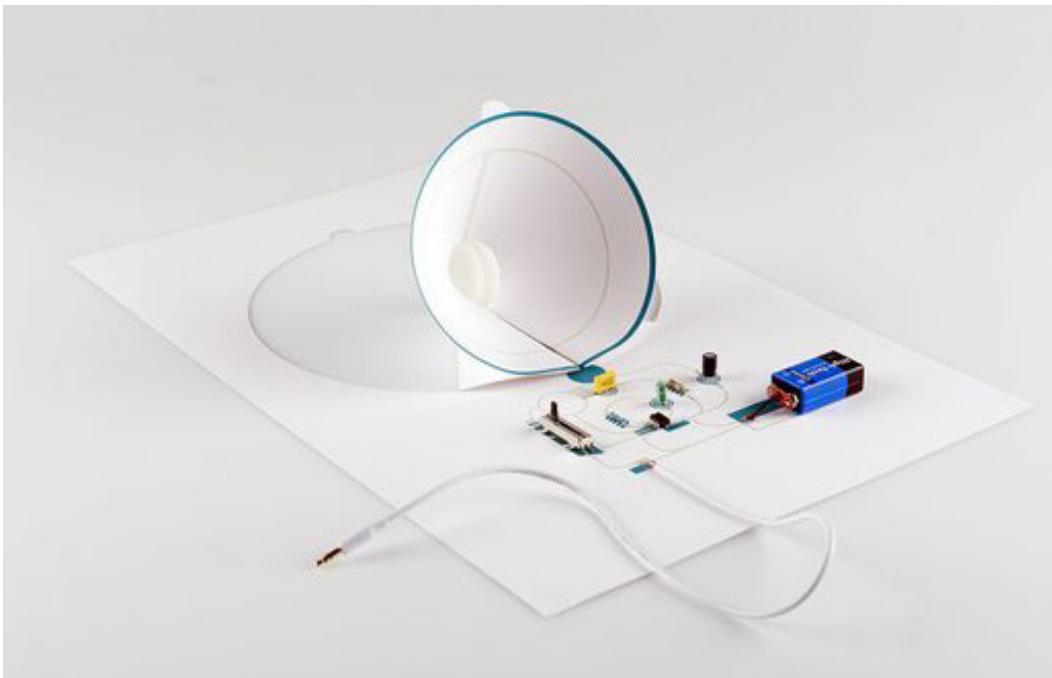

Divers. Objet décoratif à poser ou accrocher.

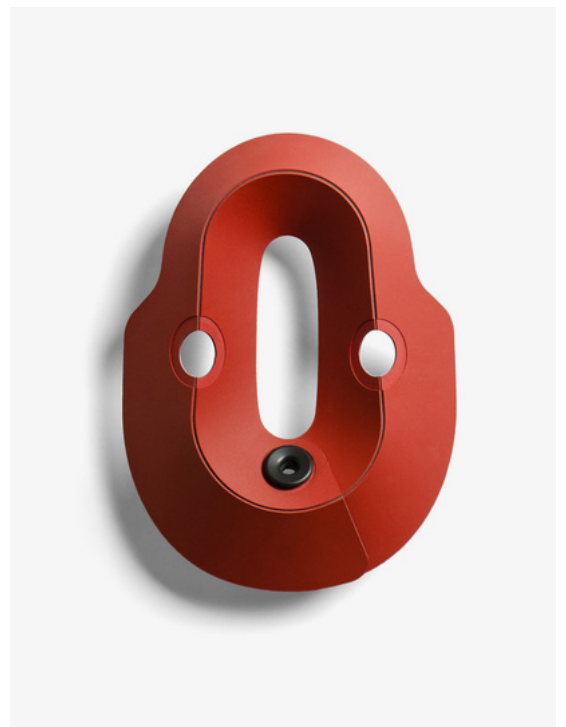

Divers. Objet décoratif et décorations. Mobile.



Re-use. Ready-made.

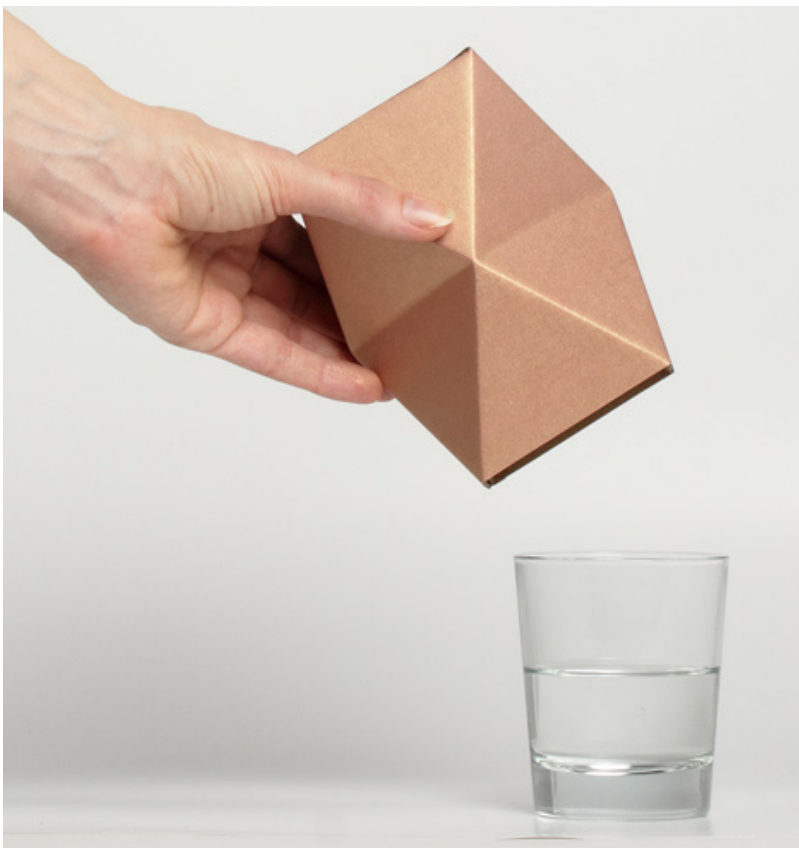



Moule pour produire autre chose.



<http://www.dezeen.com/2012/02/02/dezeen-screen-faciture-by-phil-cuttance/>

Exemples des résultats de prototypes réalisés par les étudiants SHS au cours des dernières années.

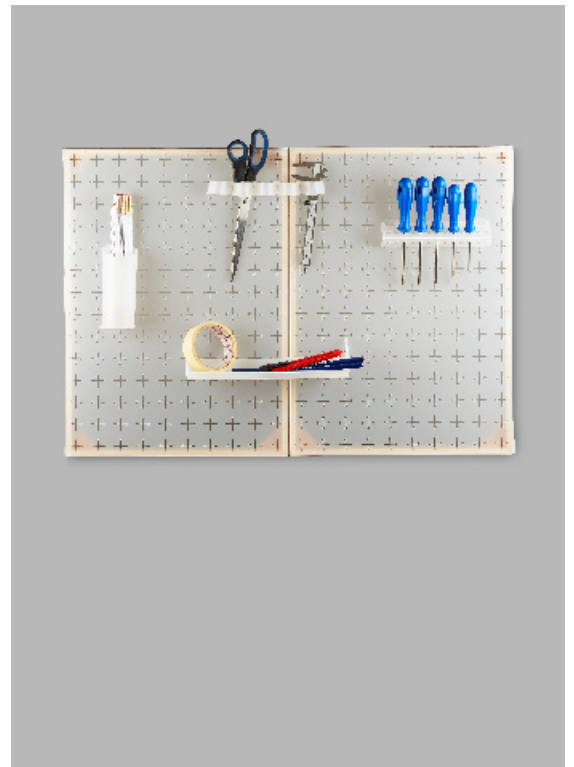

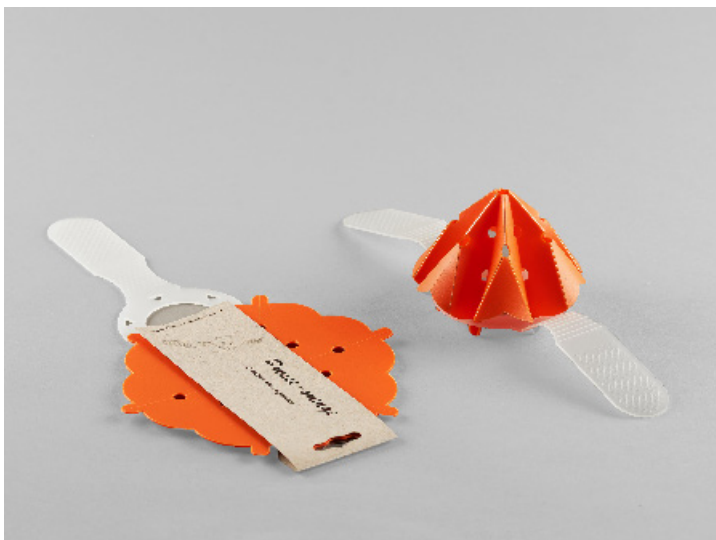

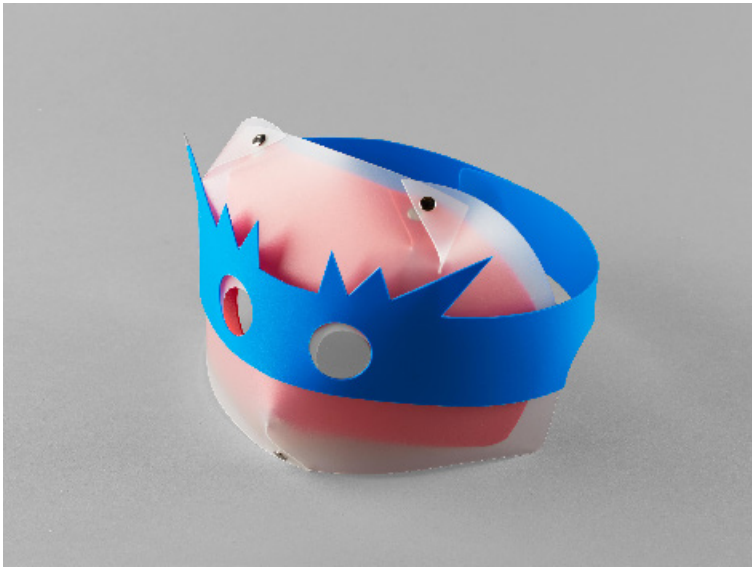

# Design Processus et Maquettes. Exemples de développement d'un produit.

Recherche de forme.

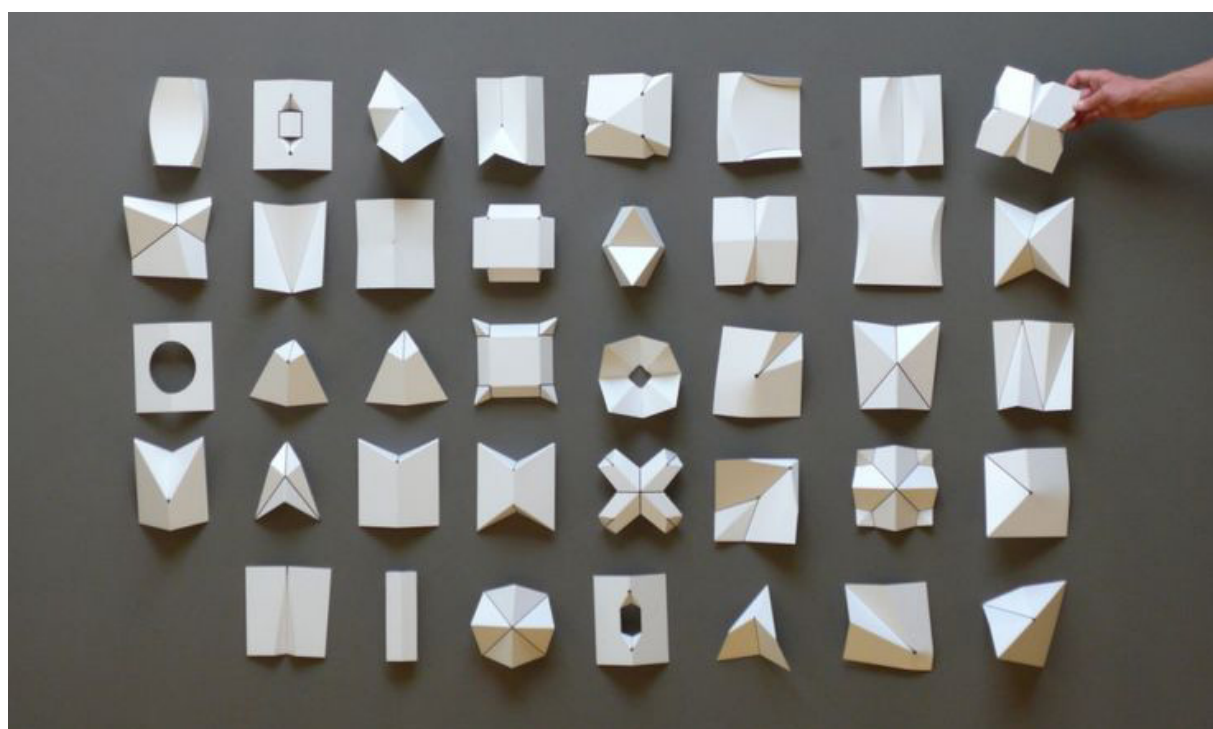

Maquettes, Maquettes, Maquettes...





Maquettes, Maquettes, Maquettes...

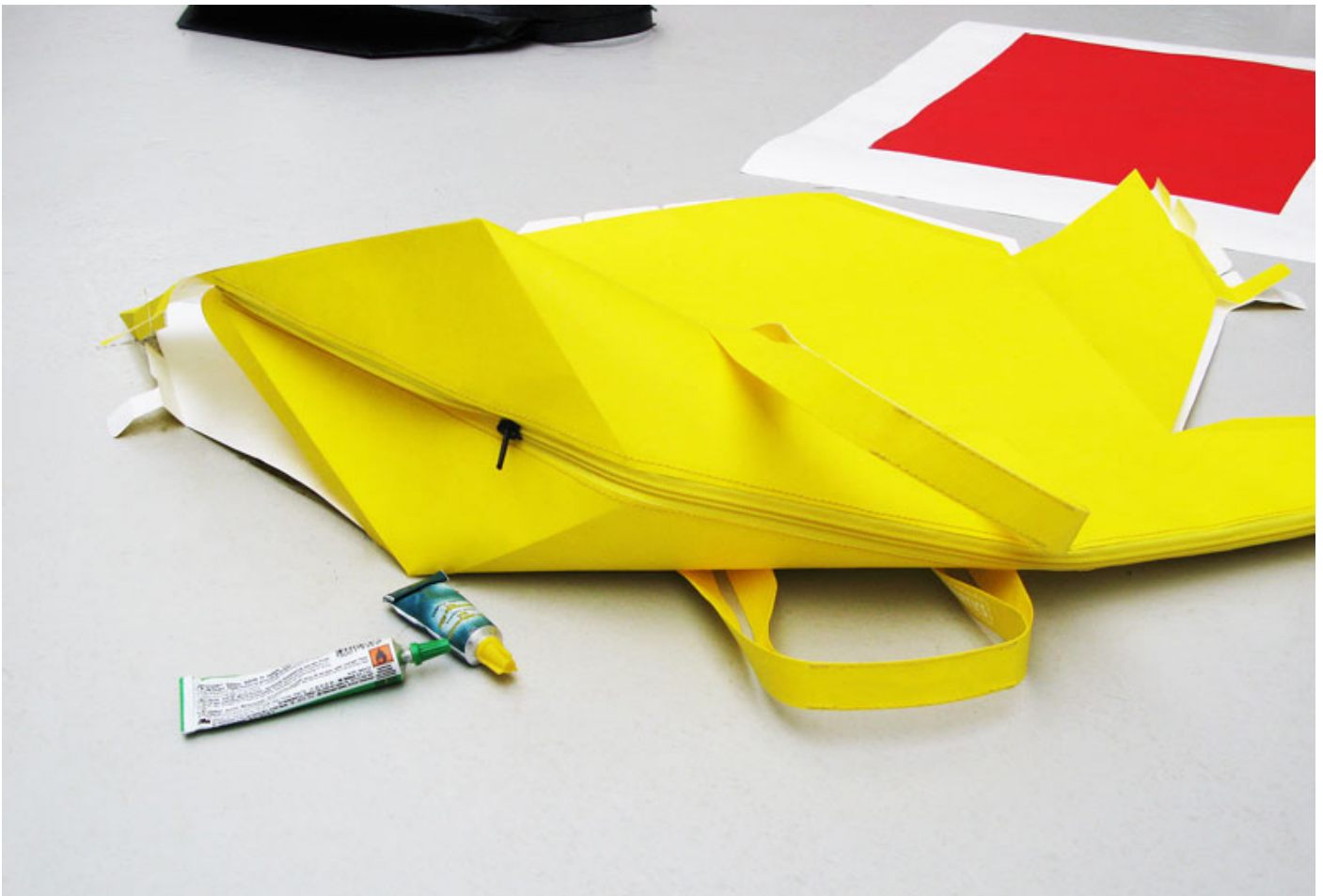

Maquettes, Maquettes, Maquettes...



## Maquettes et tests.

