



Laser Safety

Online training



Laser safety online training - introduction

- ▶ Welcome to the EPFL Laser safety online training!
- ▶ This training will help you **understand** direct and indirect **hazards** related to the use of lasers and **explain safety measures** applicable to the use of class 3B and class 4 lasers at the EPFL.
- ▶ Please, follow the training carefully, as **you will be given a test** to answer after finishing the training. Passing this test is prerequisite for accessing your laser lab. **Passing grade credit is 80 %** and the test can be attempted three times at maximum.

Terminology and measure units

All lasers

WAVELENGTH

nm or **μm**
(THz, GHz, cm^{-1})

BEAM DIVERGENCE

mRad

BEAM DIAMETER

mm at aperture

Continuous laser

POWER

Measured in **W** or **mW**

Pulsed laser

ENERGY

J or **mJ**

PULSE LENGTH

ms, **ns**, **ps**, **fs**

REPETITION RATE

Hz

1. Laser light properties

2. Understanding laser hazards

3. Laser classification

3. Laser risk controls

Wavelength	Radiation name
100 - 280 nm	UV C
280 - 315 nm	UV B
315 - 400 nm	UVA
400 - 700 nm	Visible
700 - 1400 nm	IRA
1400 - 3000 nm	IR B
3000 - 10 ⁶ nm	IR C

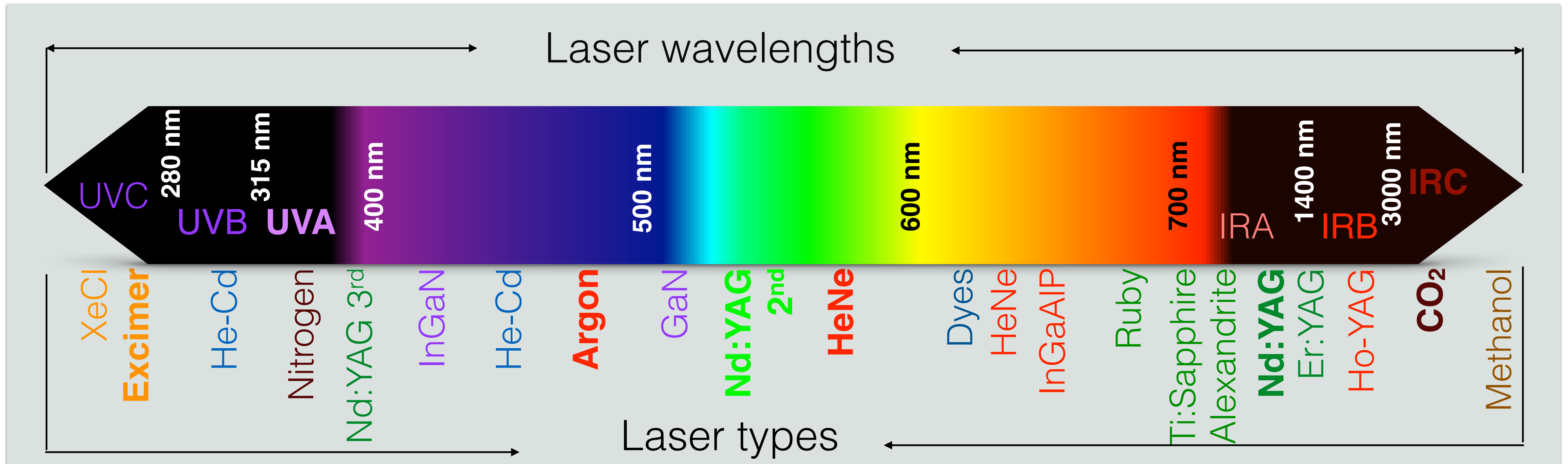

broadband sources vs. LASER



polychromatic
higher divergence
incoherent



monochromatic
coherent
low divergence
can be focused to a spot

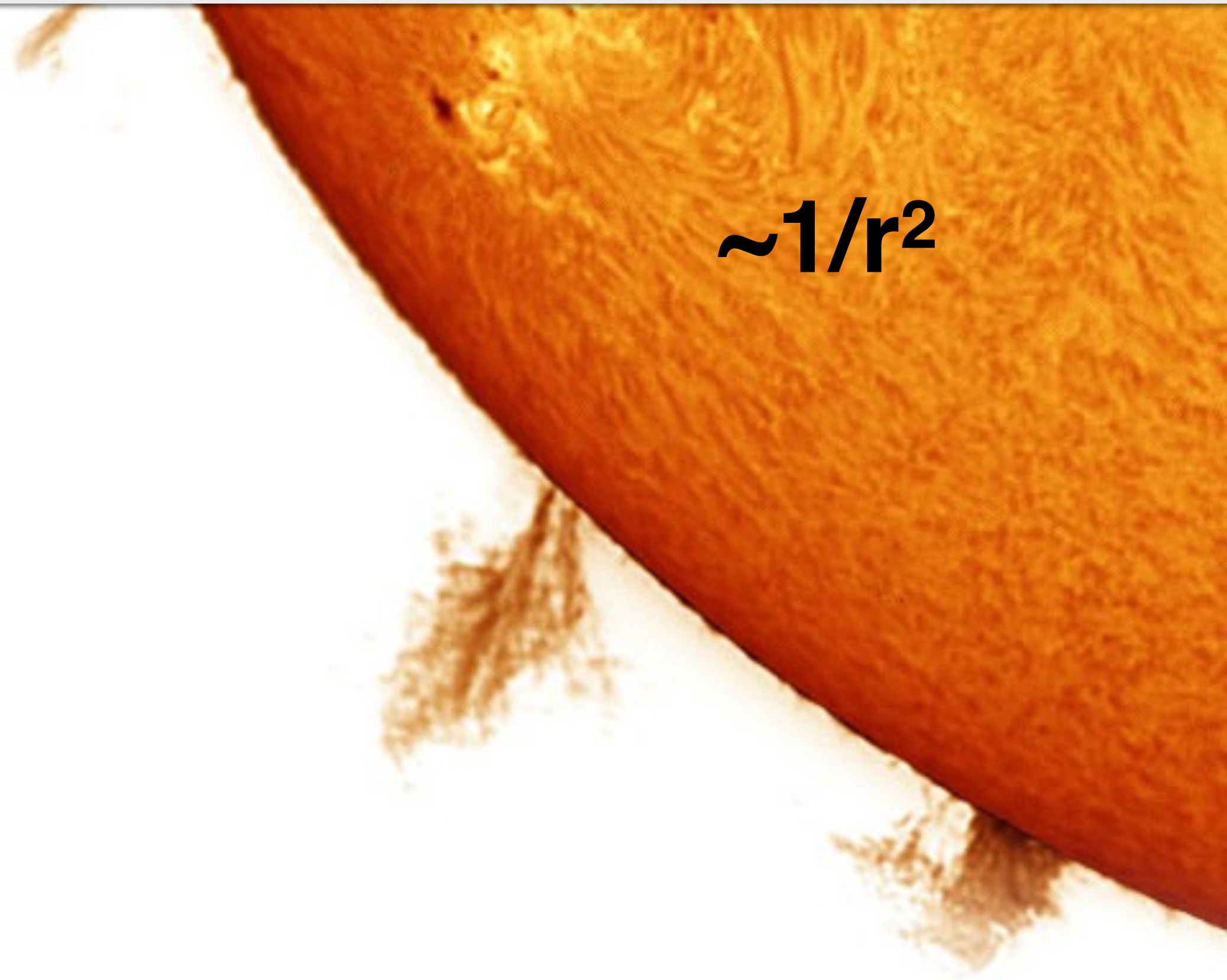

Source	Power (W)	Irradiance (power incident on a surface) (W/m ²)
Sun	$4 \cdot 10^{26}$	(at the surface of the Earth) 1400
Incandescent light bulb	100	(at 1 m from the bulb) 8
He-Ne Laser	$5 \cdot 10^{-3}$	1100
CO₂ Laser	20	$4 \cdot 10^6$

▶ Wavelengths in the range 400-1400 nm can be focused on the retina (**retinal hazard range**).

▶ **700-1400 nm** are **invisible!**

1 mW laser

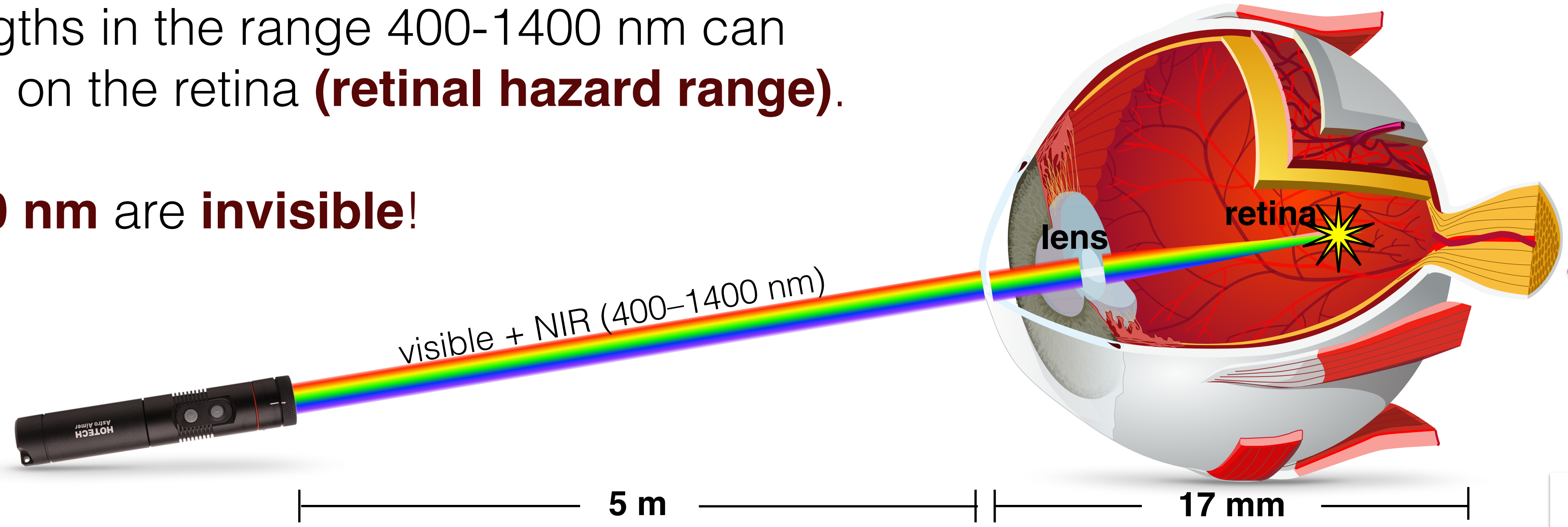

Spot size:
2 μm
Irradiance
300 MW/m²

2 000 000 X more

100 W light bulb

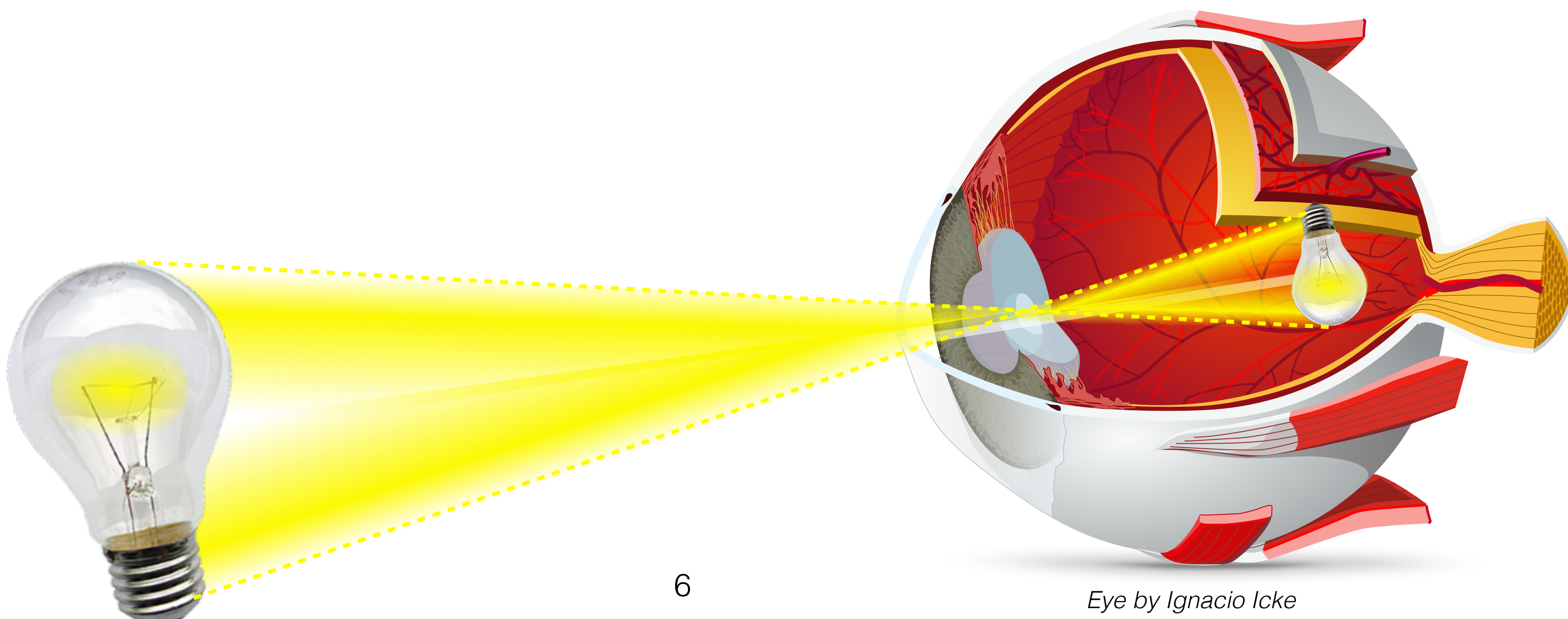

Spot size:
300-400 μm
Irradiance
150 W/m²

Thermal injuries of the retina



Retinal damages can cause **instantaneous loss of the fine vision.**



4 days
Subretinal hemorrhage



26 days



retinal tissue does not regenerate, **the damage is permanent !**

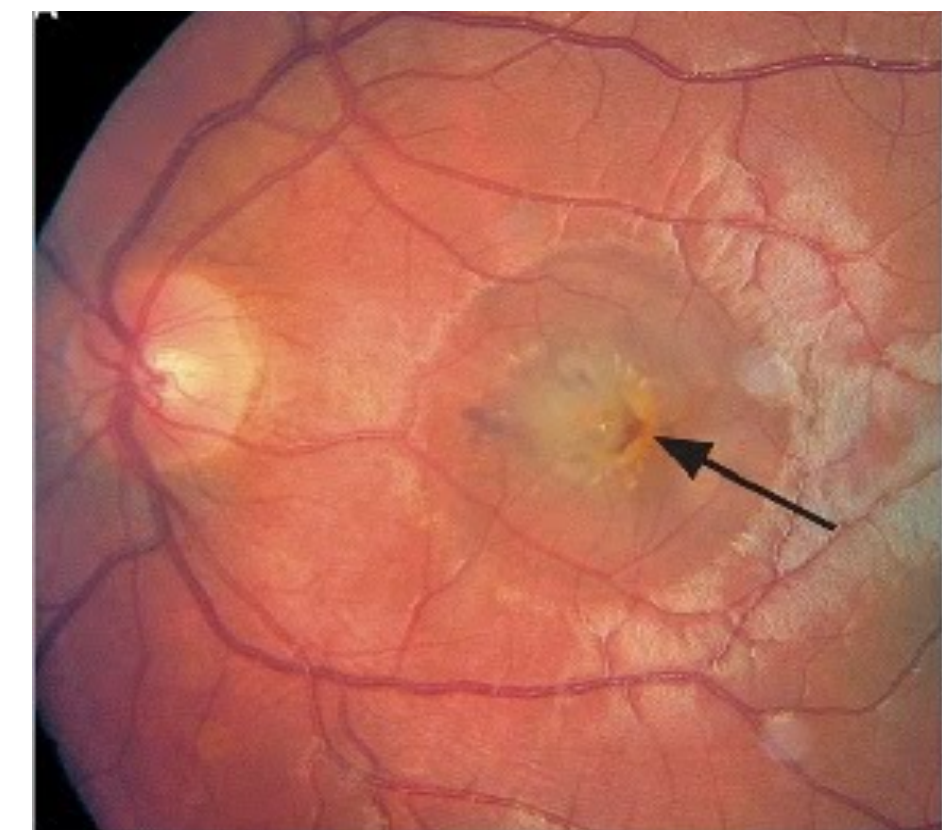

Retinal damage with laser pointer

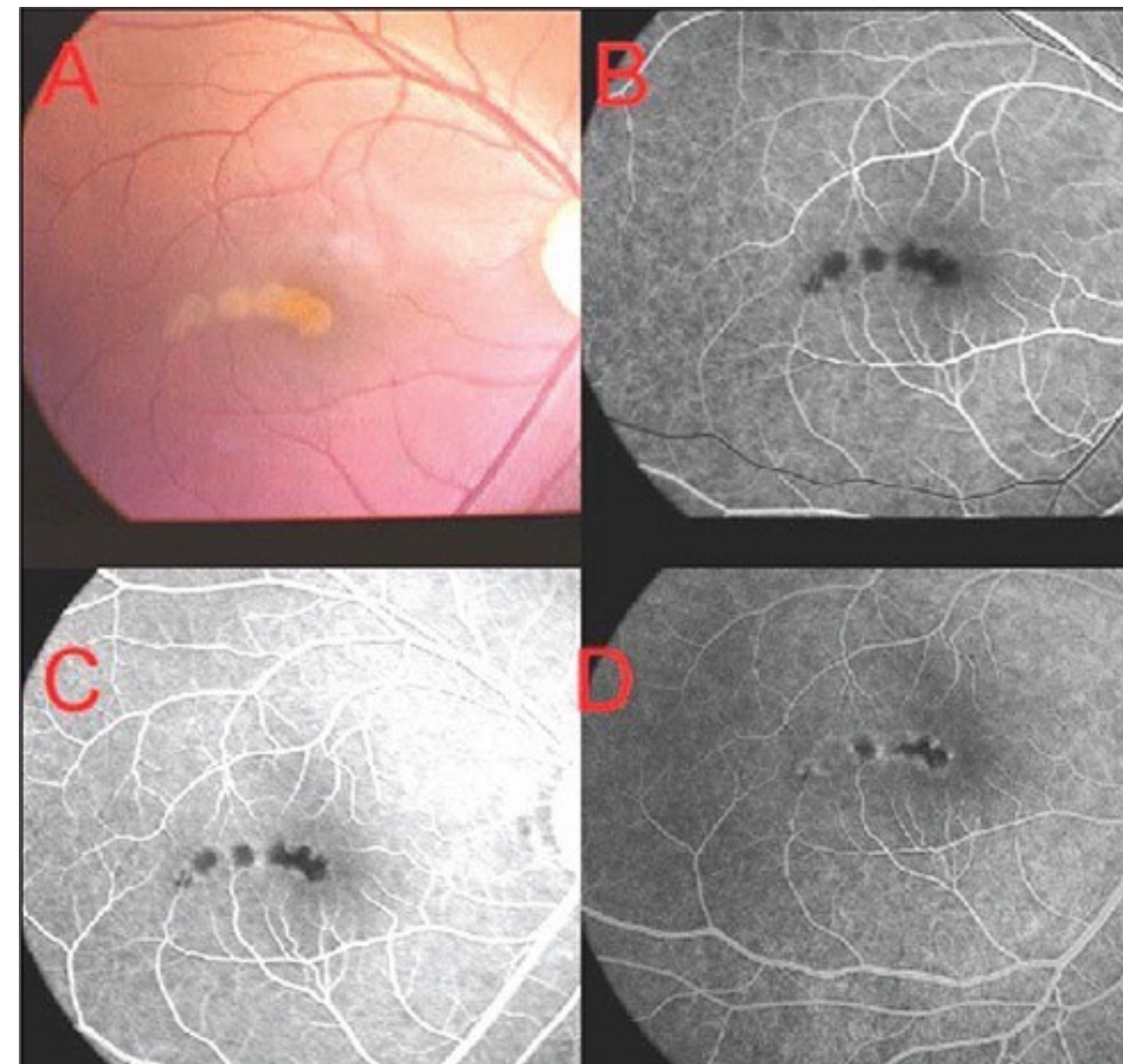

Multiple burn spots

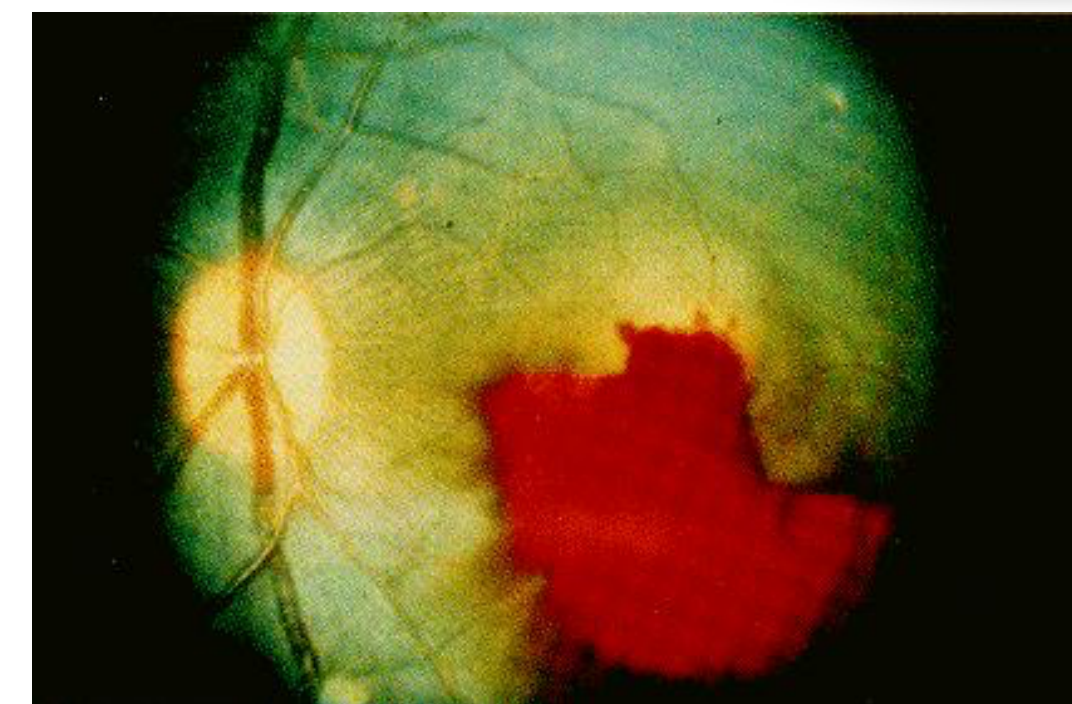

Profuse hemorrhage into the vitreous

Interactions with the eye, wavelengths (λ) outside 400-1400 nm range

FIR + FUV (> 1400 nm, < 300 nm)

Absorbed
by the cornea!

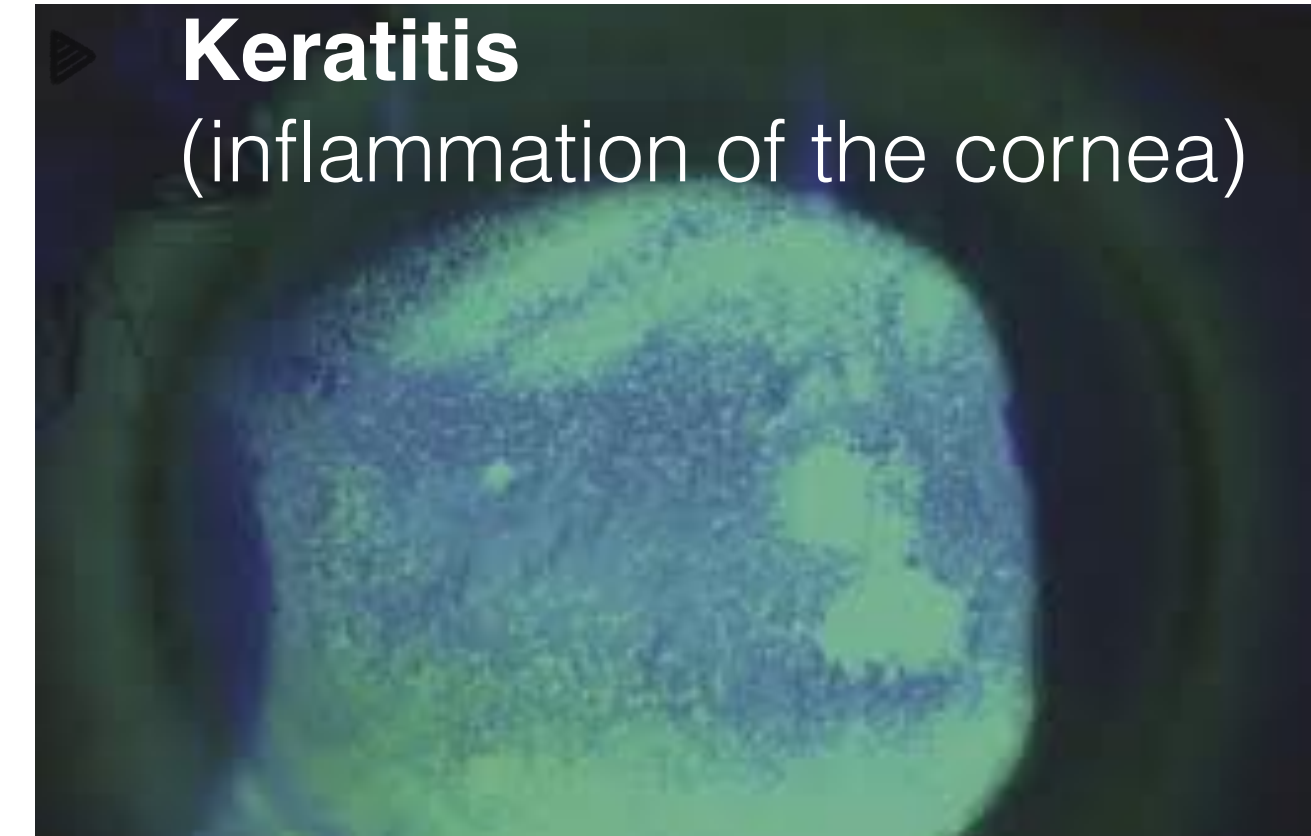
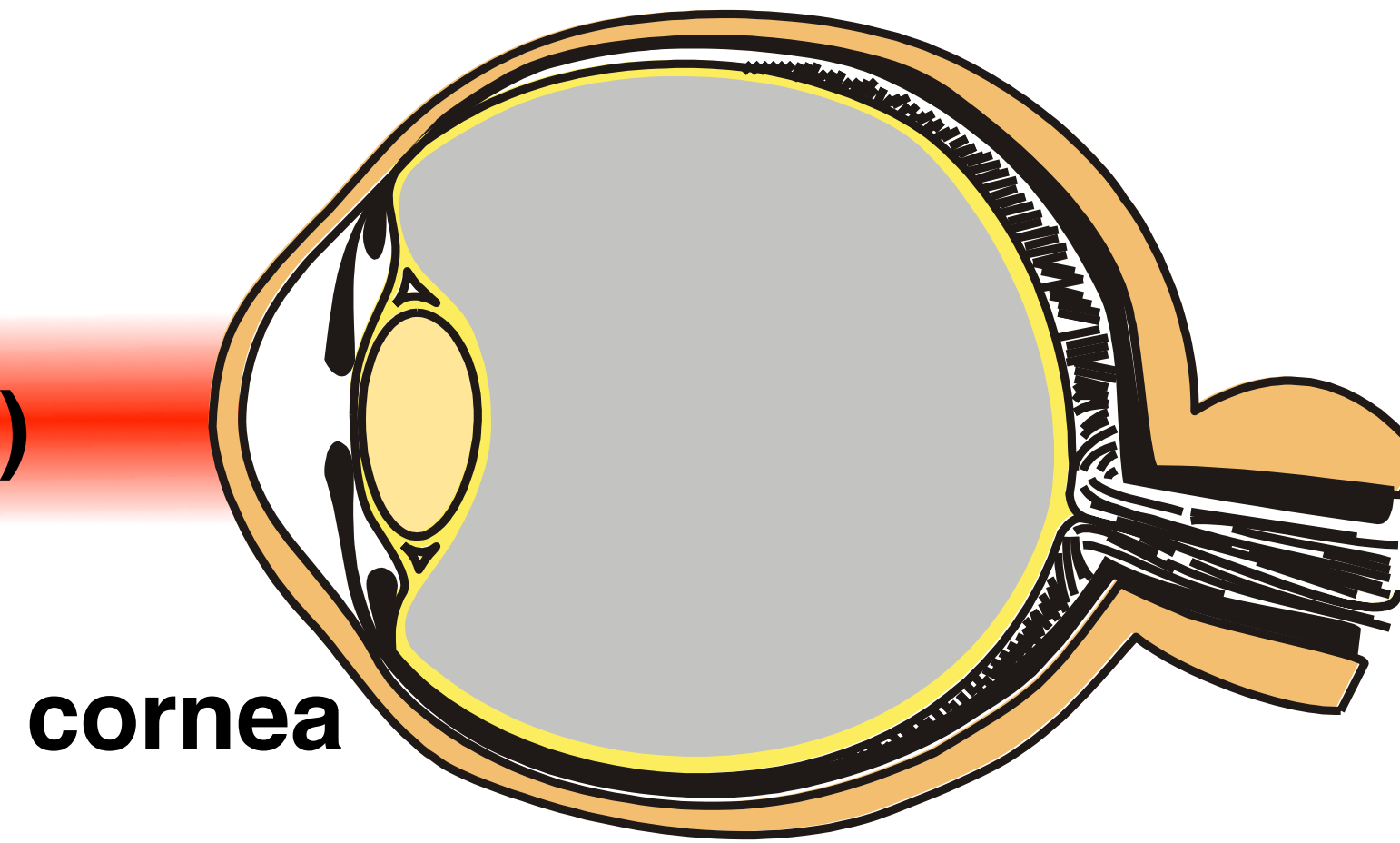

Ultraviolet (300–400 nm)

Absorbed
by the lens!

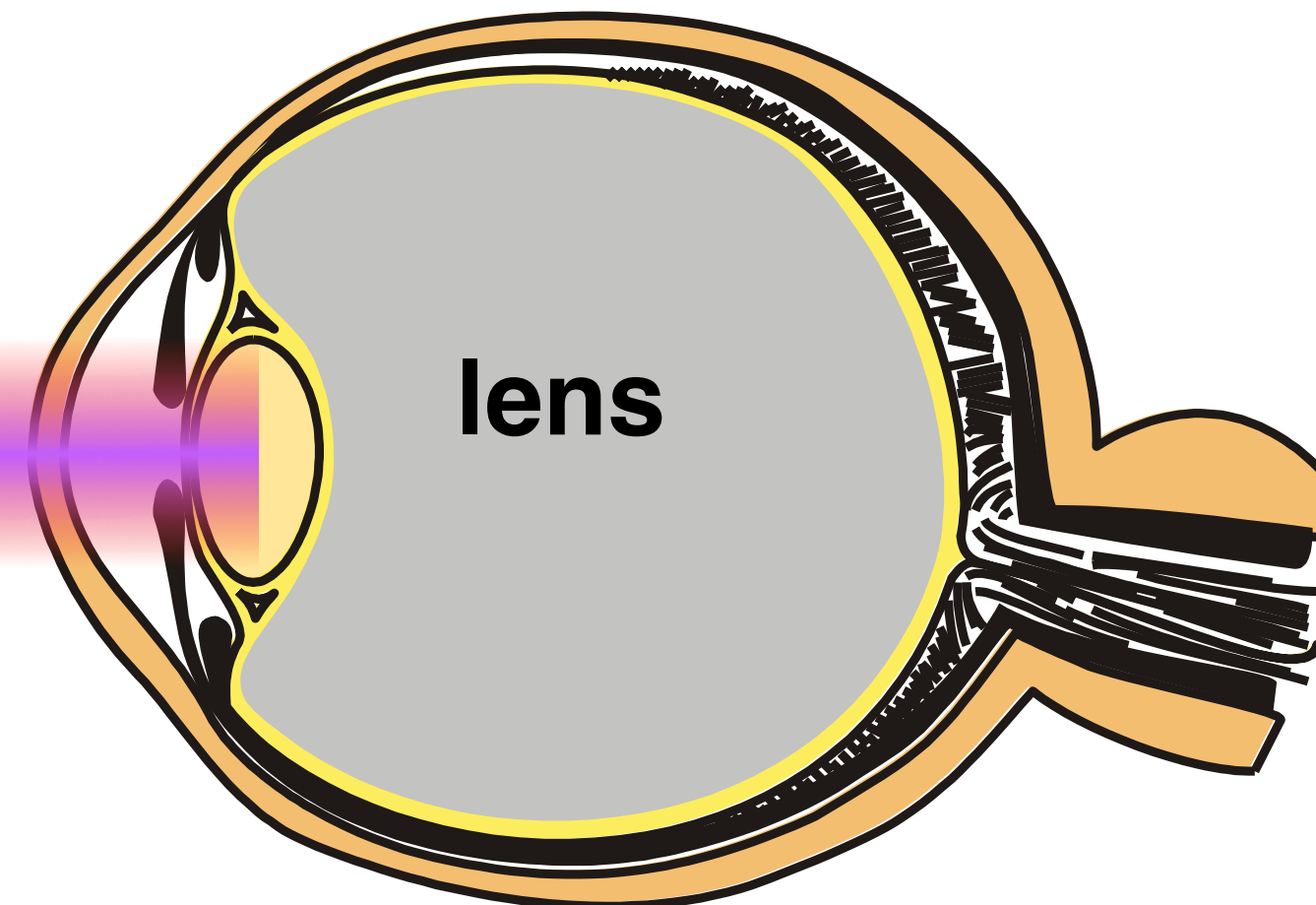

- ▶ Thermal damages of the lens @ 300-400 nm
- ▶ **Cataract** (clouding of the eye's lens) @ 300 nm

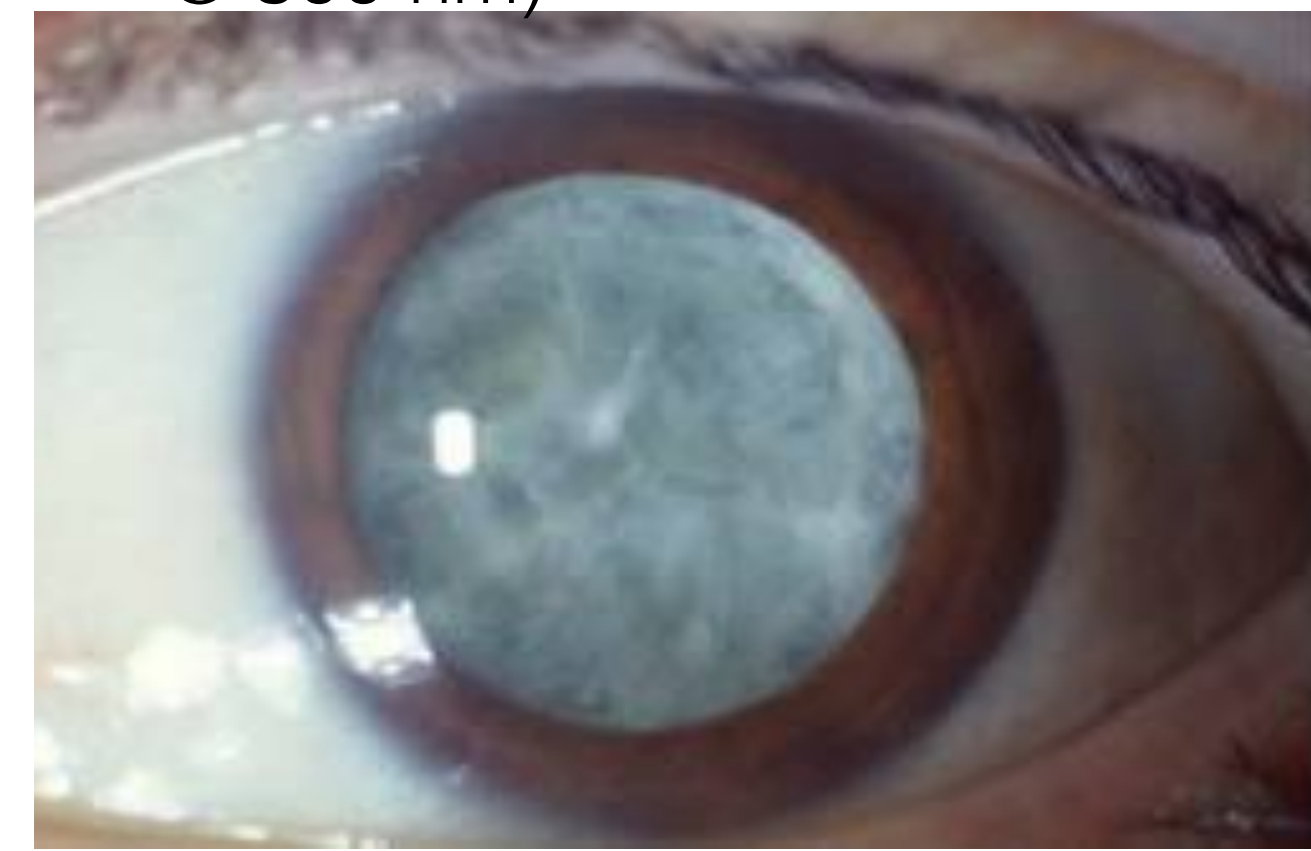

Facts on the aversion response (blinking effect):

- ▶ Natural defence mechanism
- ▶ Works only with visible light
- ▶ Average response time: 0.25 seconds
- ▶ So this mechanism can protect us for class 1 and 2 lasers only



0.25 s

Variation of pupillary aperture determines the energy that penetrates the eye

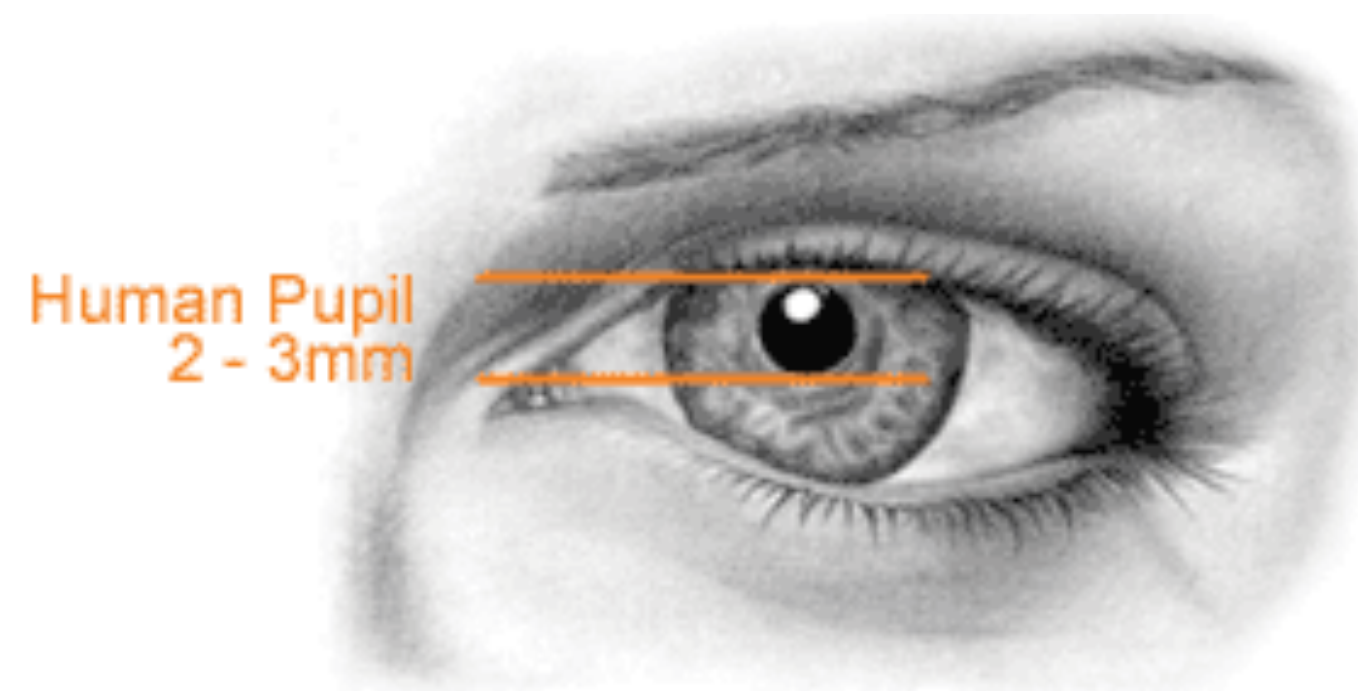

Bright Conditions

2 mm day light
3 mm interior light

Keep the lights on
as much as
possible !

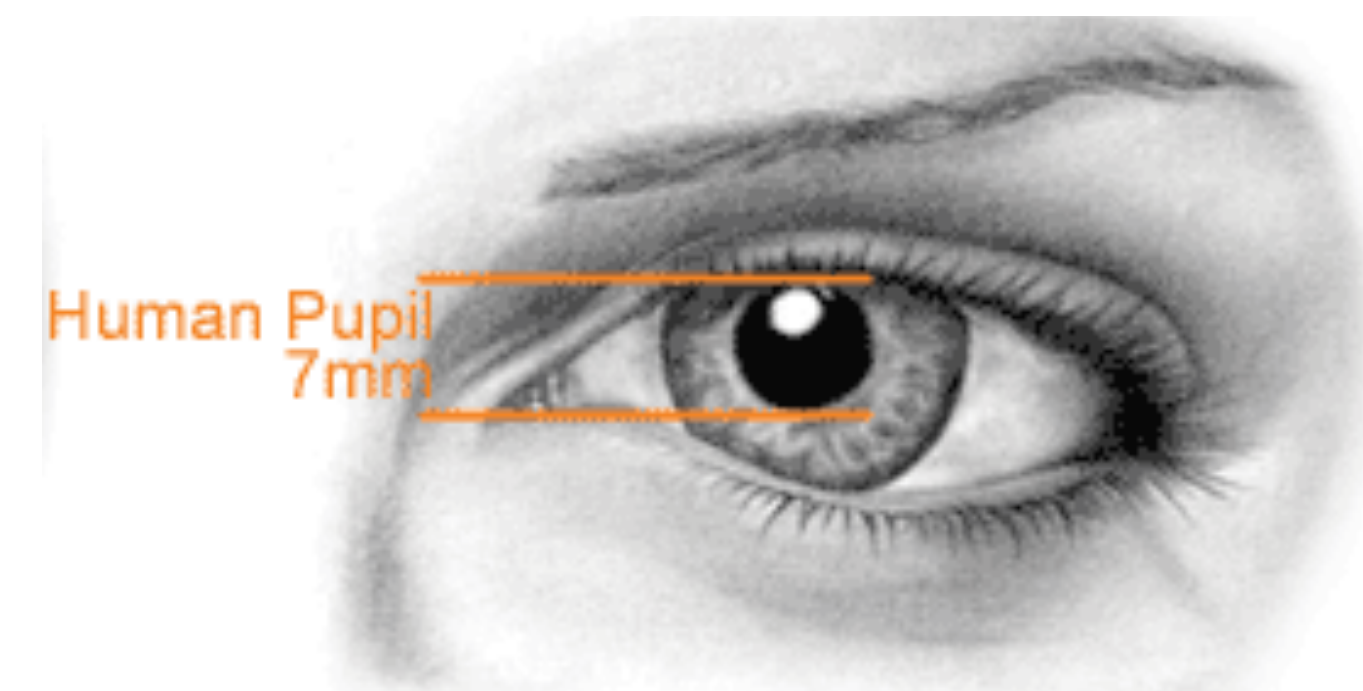

Low Light Conditions

7 mm semi-darkness (twilight)
8 mm pupil dilated for medical exam.

Specular vs. diffuse reflection

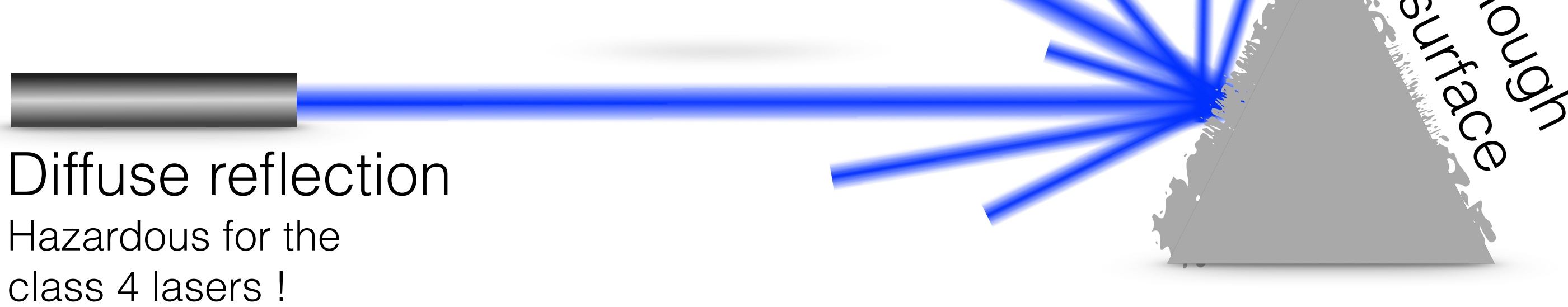
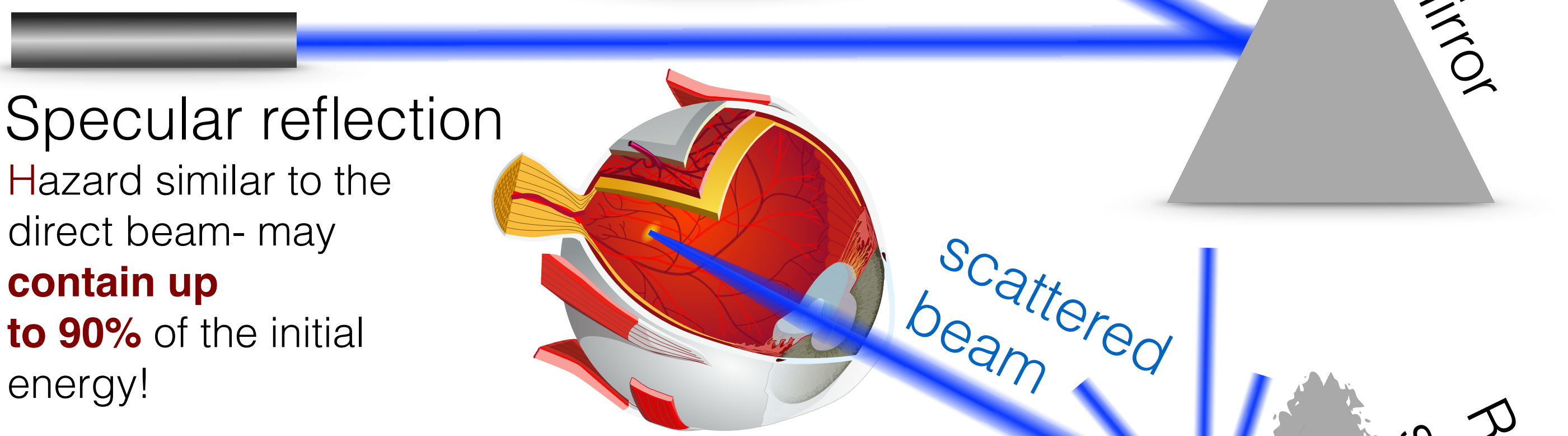
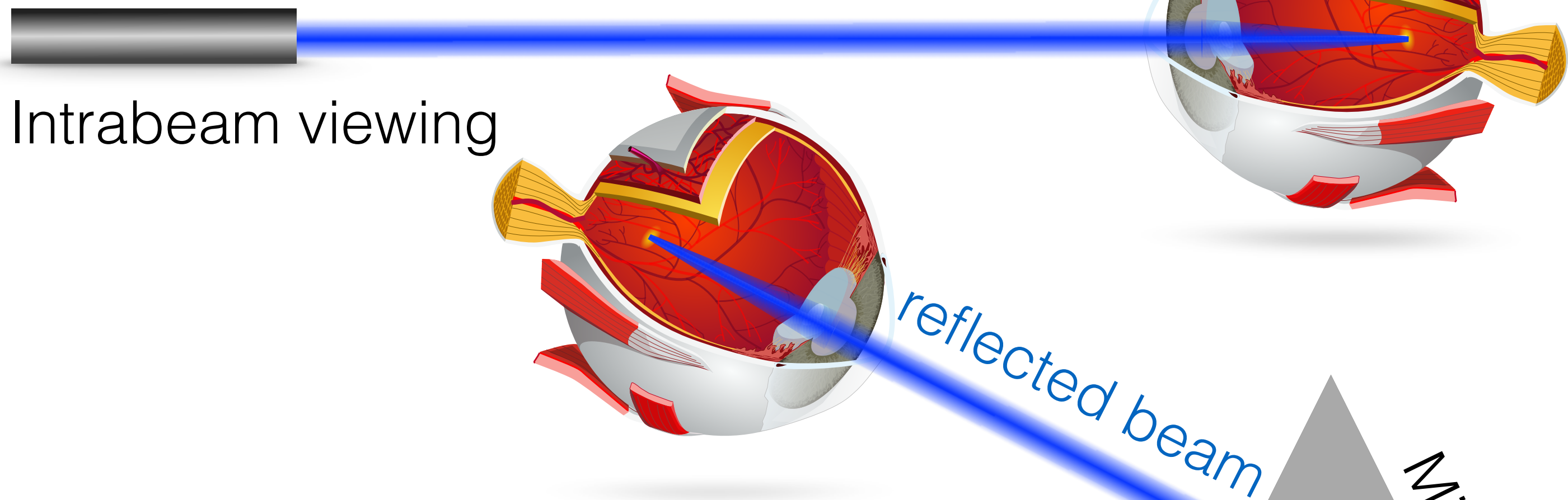

Bad idea



Be careful



Thermal skin damage (Infrared + Visible+ near UV)

 **10 μ s – 5 s**

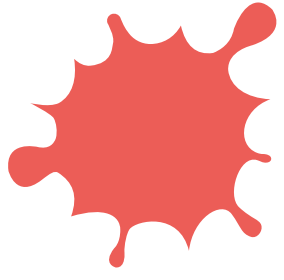
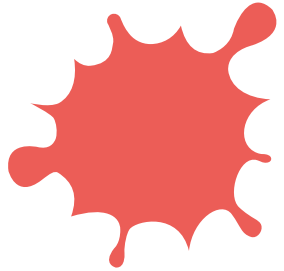
-  Conversion of light to heat
-  Coagulation of proteins

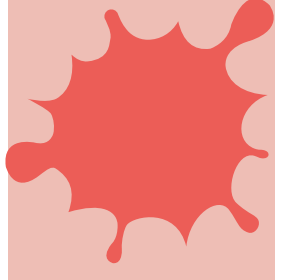
 Burns are a function of time and temperature

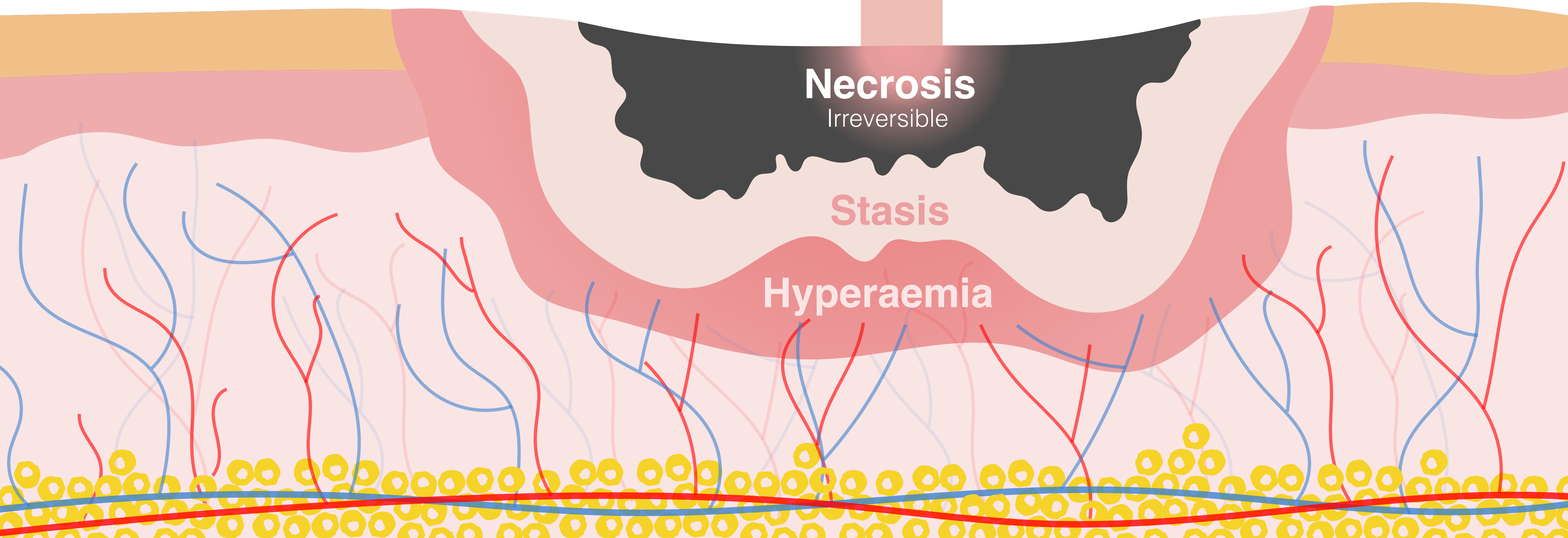

Photochemical skin damage (medium and far UV)

 **> 5 s**

 Destructions, loose of space structure

 Denaturation, and cellular disorganisation.

 Consequences not always immediate

 Cancers can be provoked on the longer term.

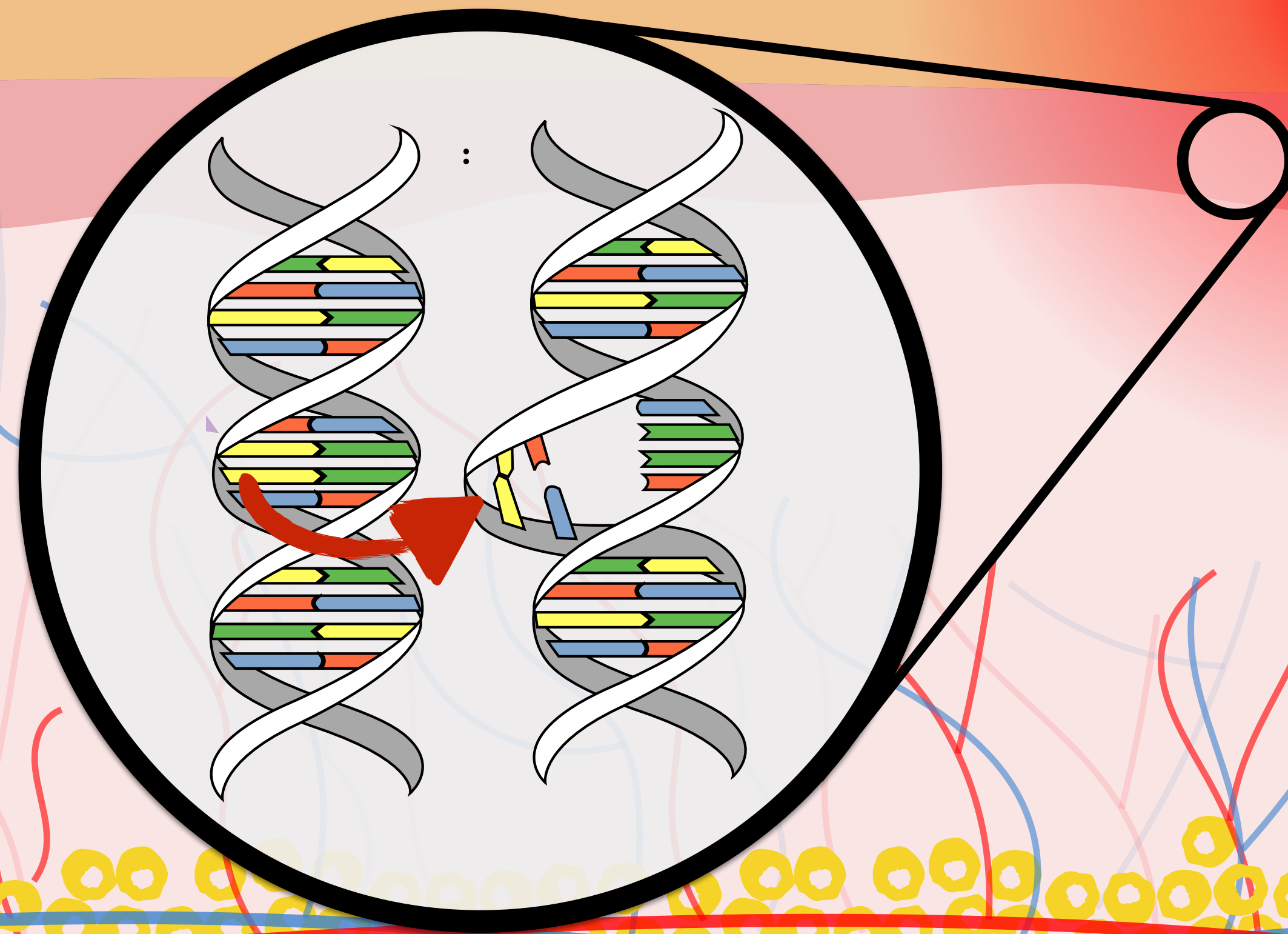

Examples of skin damage



Hyperpigmentation

Typical for UVA lasers (315 nm to 400 nm).
Here after laser hair removal



Melanoma

Risks of carcinogenesis for UVB lasers (280 nm to 315 nm). Damage to the DNA or carcinogenic intracellular viruses.

surgical-dermatology.com



Pigment-darkening effect

Typical for UVC lasers (200 nm to 280 nm) and UVA. Less harmful to skin since if exposure to small levels

skincancer909.com



patienthelp.org

Erythema

Summary of effects for different wavelengths of laser beams

Wavelength	Name	Effects on eyes	Effects on skin
180 - 280 nm	UV C	-Photokeratitis	- Sunburn - Accelerated skin aging - Skin cancer
280 - 315 nm	UV B	-Cataract related to photochemical process	- Increased pigmentation
315 - 400 nm	UV A	-Thermal damage of the lens	- Pigment darkening - Skin burn
400 - 700 nm	Visible	-Retinal injuries Photochemical and thermal	
700 - 1400 nm	IR A	-IR Cataract -Retinal burns	
1400 - 3000 nm	IR B	-Burns of cornea -Protein level increasing in the cells in aqueous humor. -IR Cataract	- Skin burns
3000 nm - 10^6 nm	IR C	Burns of cornea	

Associated (collateral) hazards

Chemical

Some lasers require hazardous or toxic substances to function.

- ▶ Example: dye lasers or Excimers, ZnSe optics for CO₂ lasers.

Electrical

Some lasers use high voltages, that can be lethal.

- ▶ Discharge lasers like Ar.

Fire

Flammable materials (e.g. acetone, ethanol used in the labs) can be inflamed by the direct beam of specular reflexion of high power CW beams of IR lasers.

Enclosure of Class 4 laser beams and terminations of some focused Class 3B lasers, can result in potential fire hazards if the enclosure materials are exposed to irradiance exceeding 10 W/cm².

Solvents used in dye lasers are flammable. High-voltage pulses or flash lamps may cause inflammation.

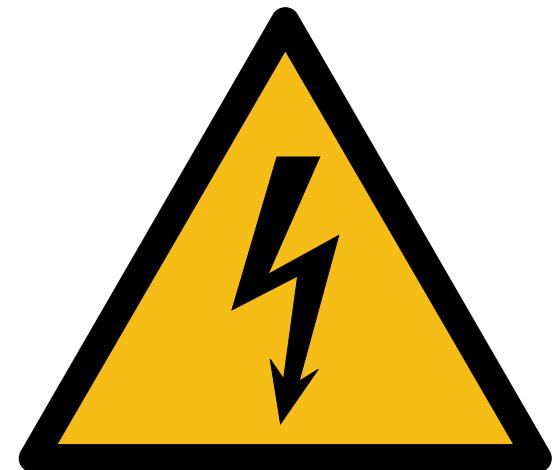

Class 1/1M



SAFE

Class 2/2M



Class 3R



Class 3B



Class 4



HAZARDOUS



International regulation on laser safety: the norm applied in Europe is 60825-1/A2. Some safety terms employed:

- ▶ **MPE** is Maximum Permissible Exposure (the maximum level of exposure to a laser without harm)
- ▶ **NOHD** is Nominal Ocular Hazard Distance (see image below)

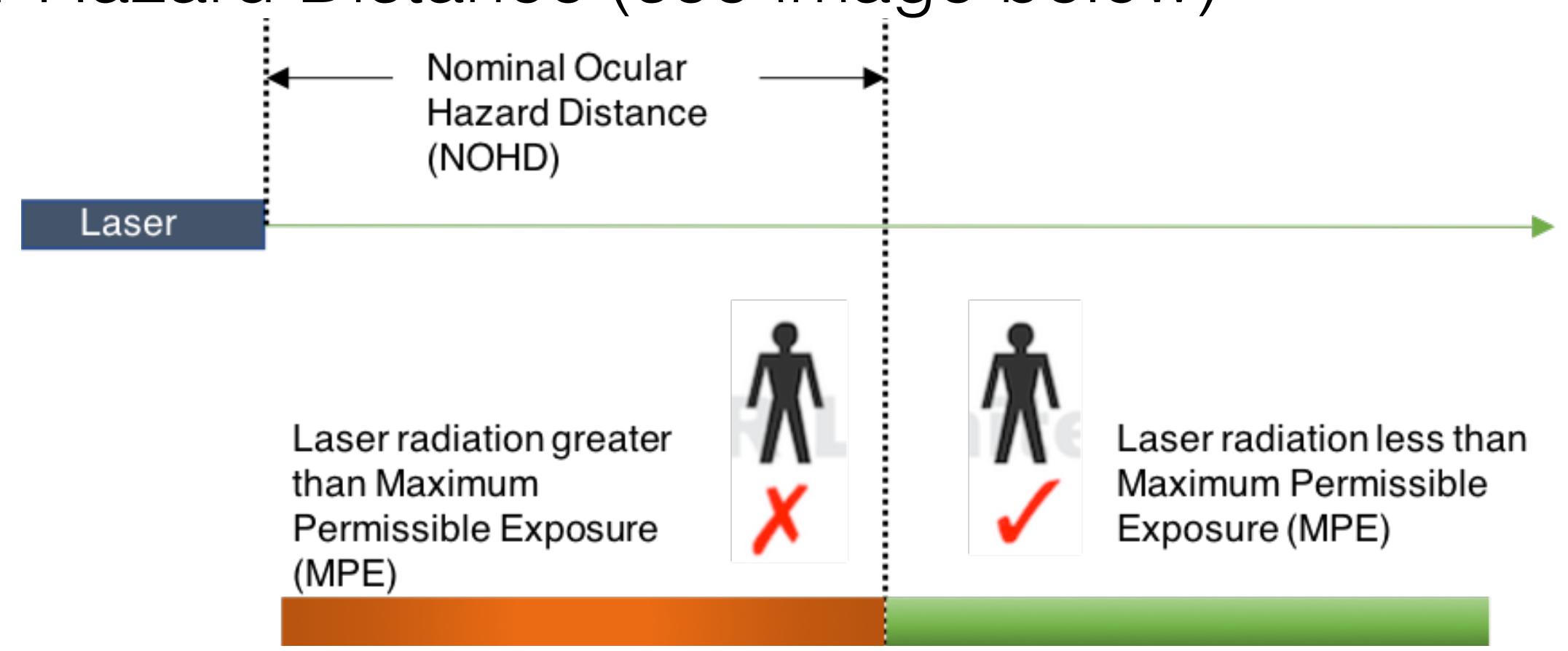

Laser classes - safety aspects

Class	Naked Eye	Magnifying optics	Specular reflection	Diffuse reflection	Skin hazard
1/1C					
1M					
2					
2M					
3R					
3B					
4					



No risk from exposure



Caution required to prevent exposure



Maximal protection required



Can ignite fire

Safety control measures for managing the risk are often divided into **4 groups that are hierarchized (order of priority)** as bellow:

1.) S trategic control measures

e.g. substitution with a lower laser class if possible.

2.) T echnical (engineering) control measures

e.g. enclosures, tubes, interlocks.

3.) O rganizational (administrative) control measures

e.g. confining the hazard zone, controlling access, training, standard operating procedures.

4.) P ersonal protection measures

e.g. goggles, gloves.

Technical control measures (to reduce the access to hazard)

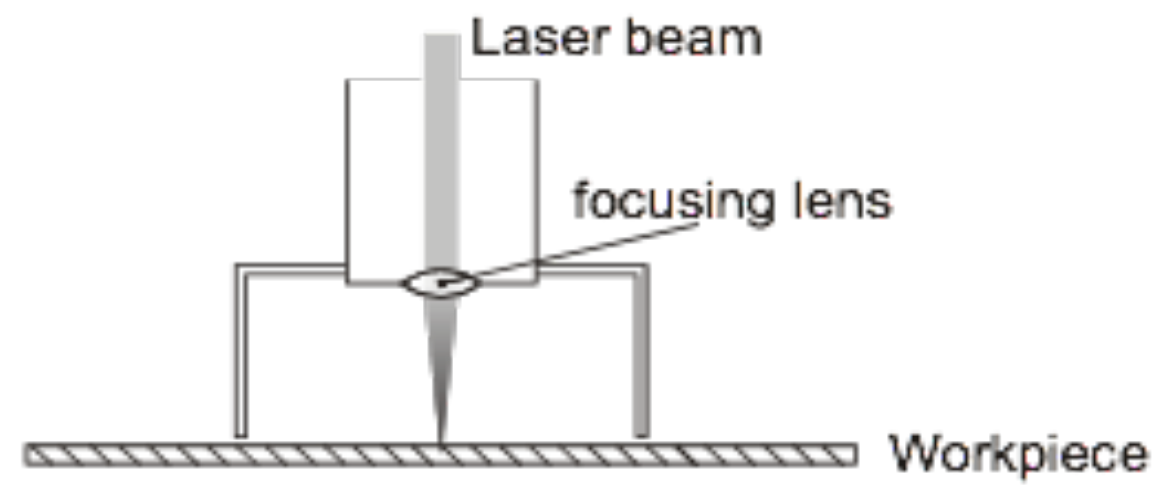

Beam enclosures

- ▶ Must be sufficiently robust and stable, and capable of containing the hazard.
- ▶ Ex: Beam tubes or other suitable covers.
- ▶ Open beam paths should be kept short, localizing the hazard within the smallest possible area.

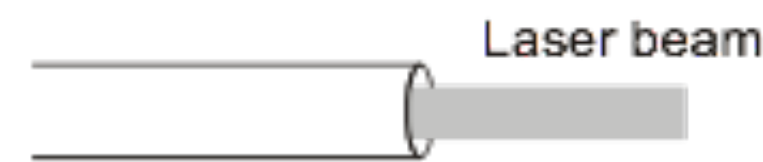
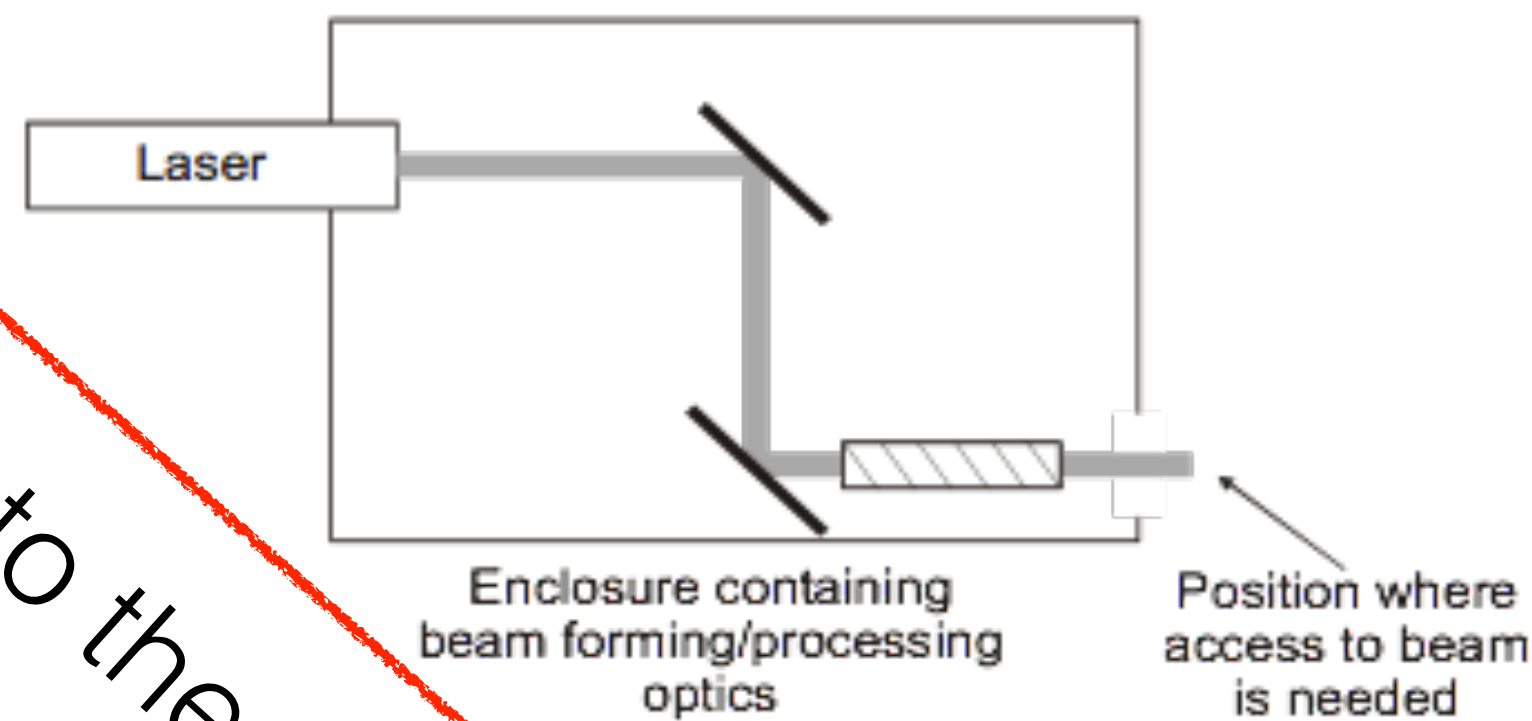

From the most to the least favorable

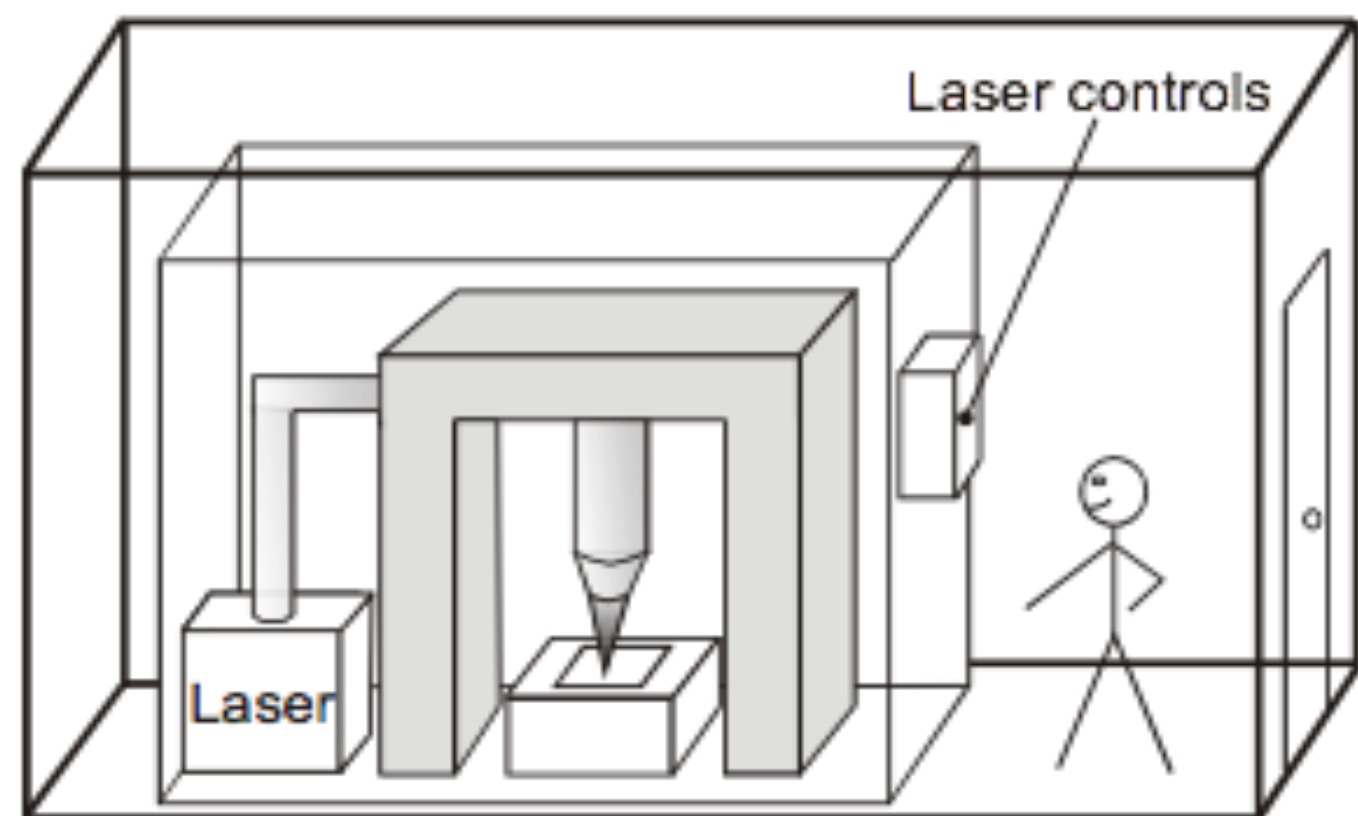

Interlocked and closed

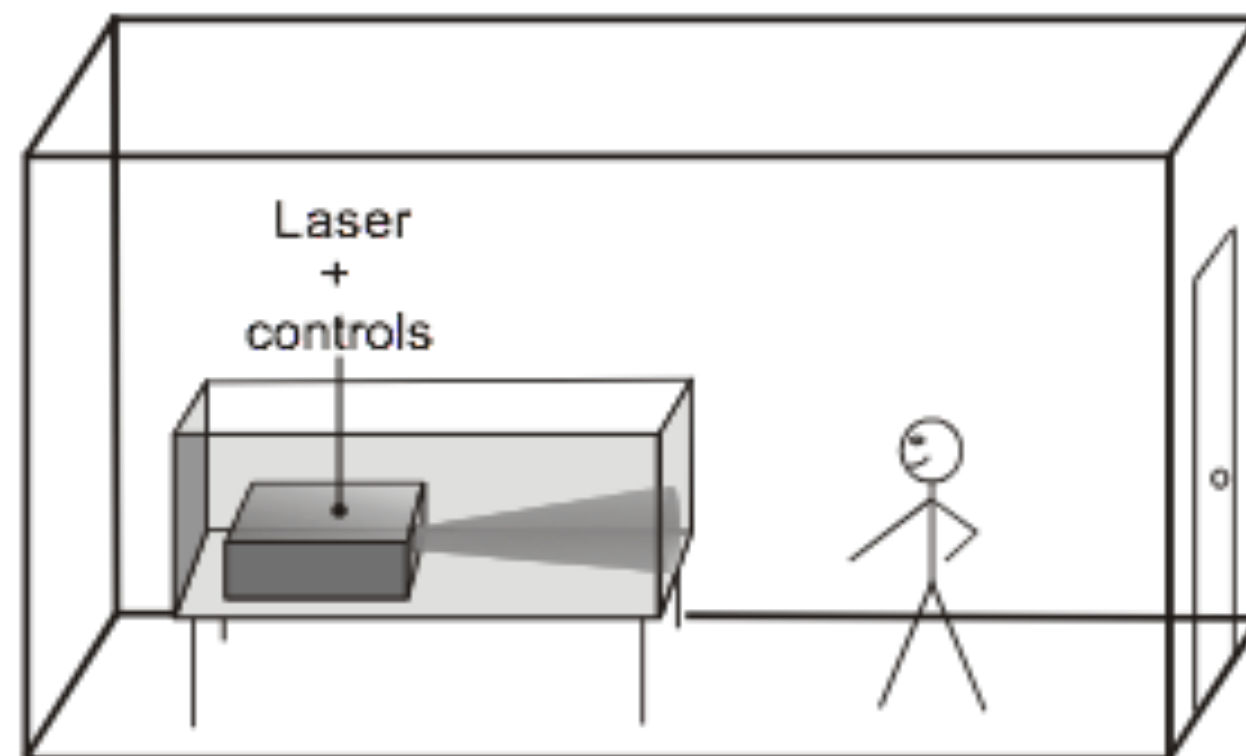

If not possible

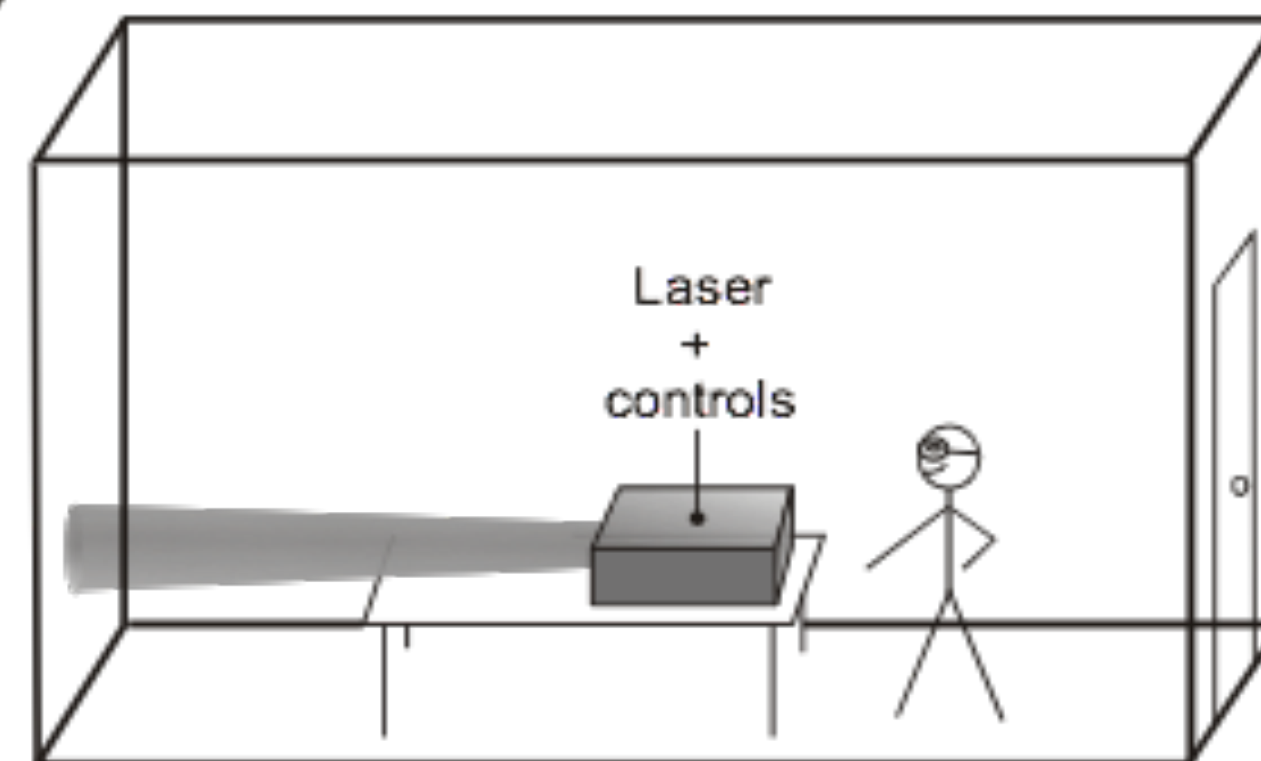

Laser hazard area
full organisational and personal
protective equipment

If the laser beam can not be **enclosed**, the **access** to laser hazard area must be **controlled** and **personal protective equipment** used

From the most to the least favorable

(1) Work with class 3B and 4 lasers @ EPFL, STOP

- ▶ Beam paths are enclosed wherever possible. Use plates to enclose lasers, tables etc. (eg: 2-2.5 mm thick aluminium plates with black anodizing)
- ▶ Optical bench is free of unnecessary reflective items.
- ▶ Beam stops are present at the end of all beam paths and are not combustible.

Complete beam enclosure



Beam confinement on the optical table

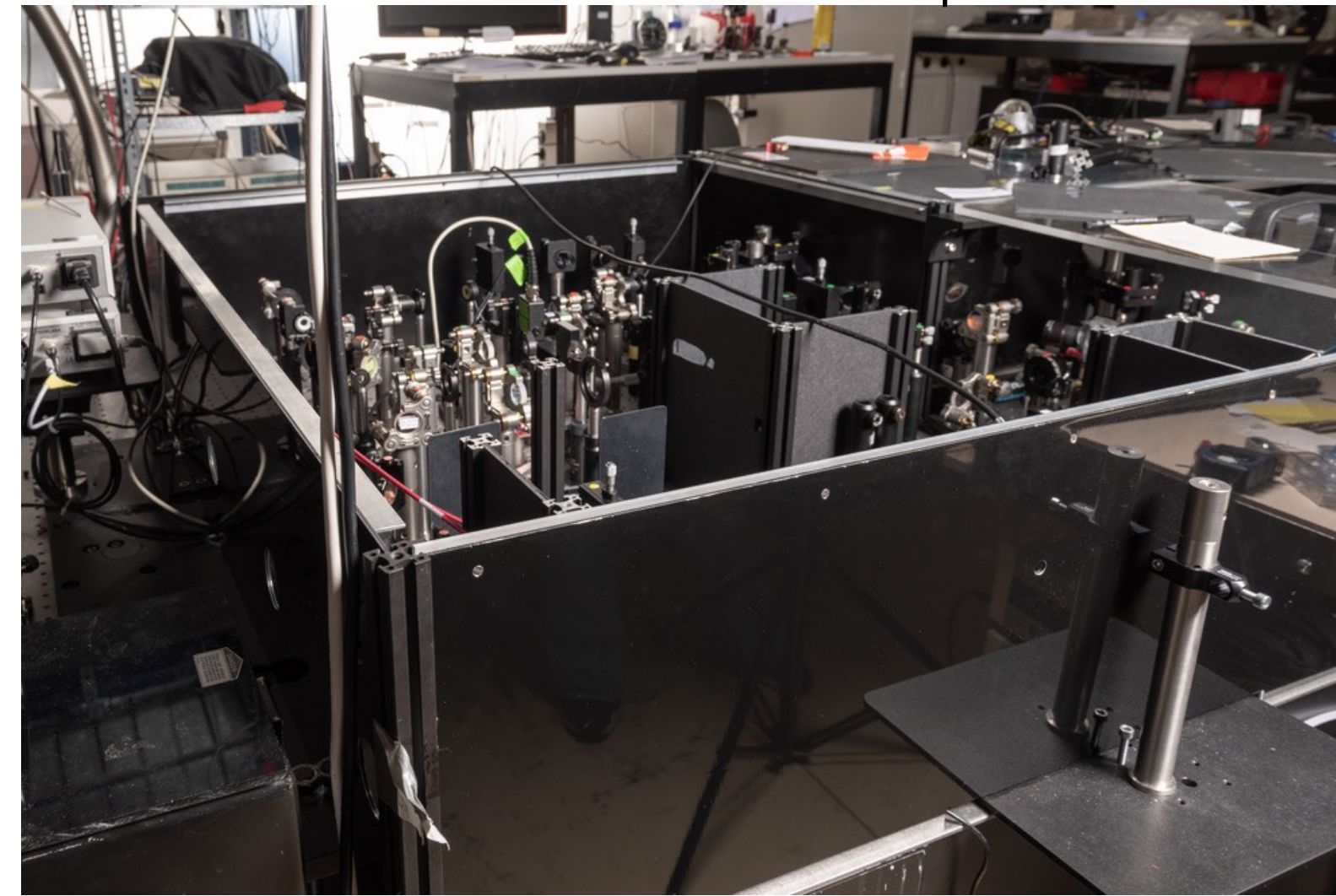

Beam stops

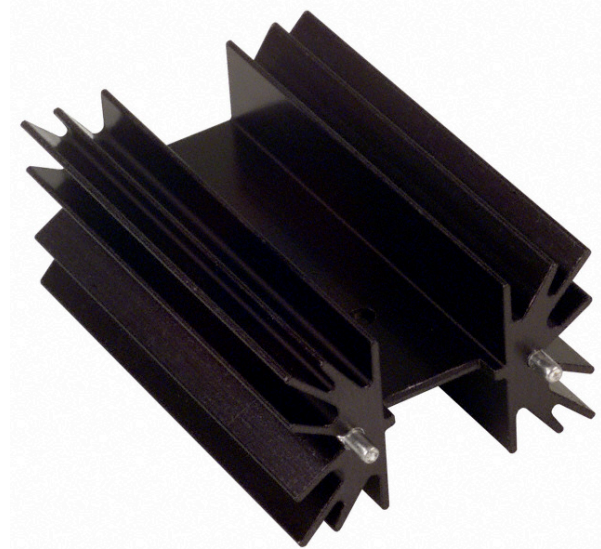
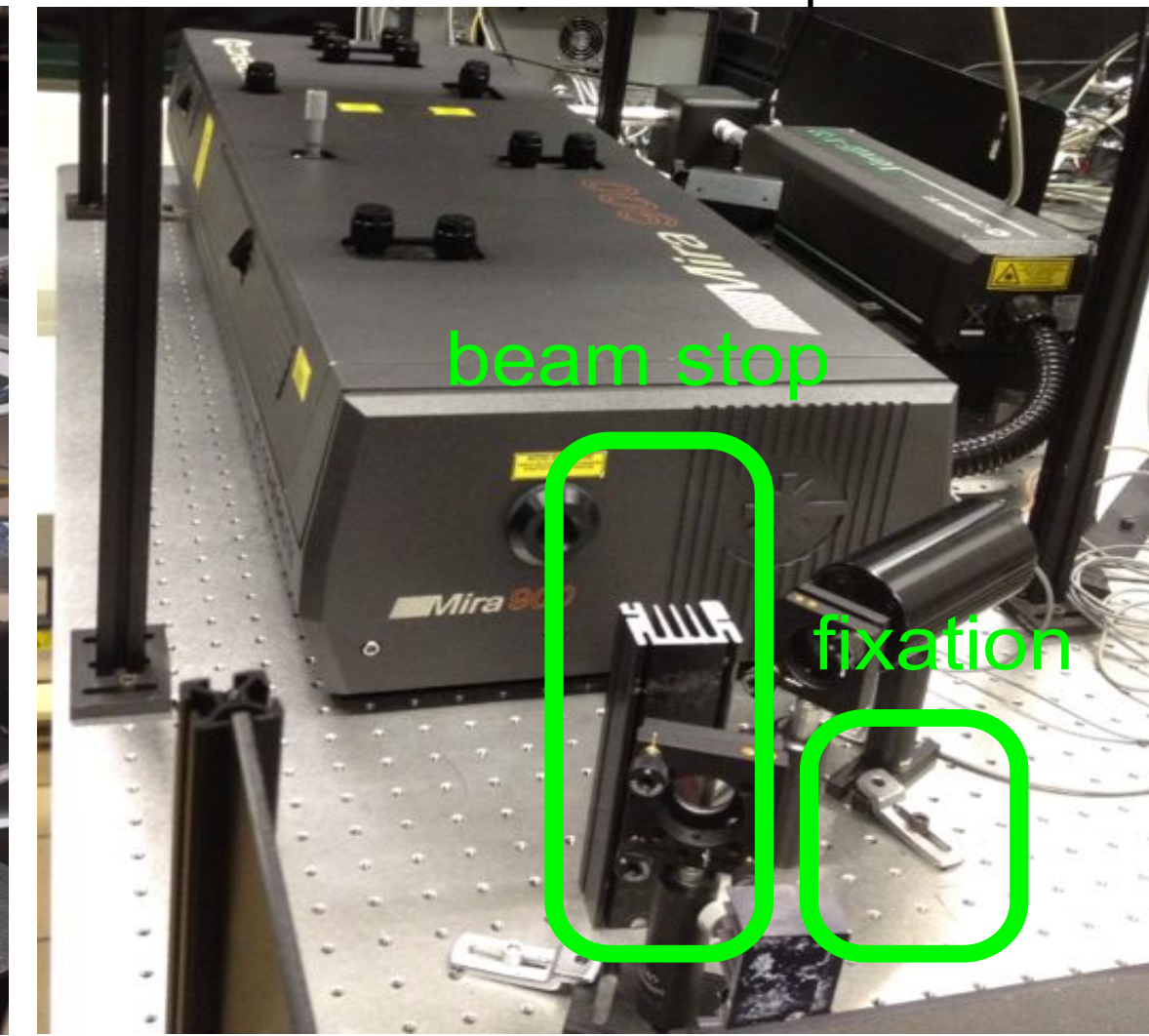

(2) Work with class 3B and 4 lasers @ EPFL, STOP

- ▶ The laser beam must be confined in a plane lower than the eyes of a seated or standing person.
- ▶ Persons sitting at the work stations (computers) have to be protected against beam exposure.

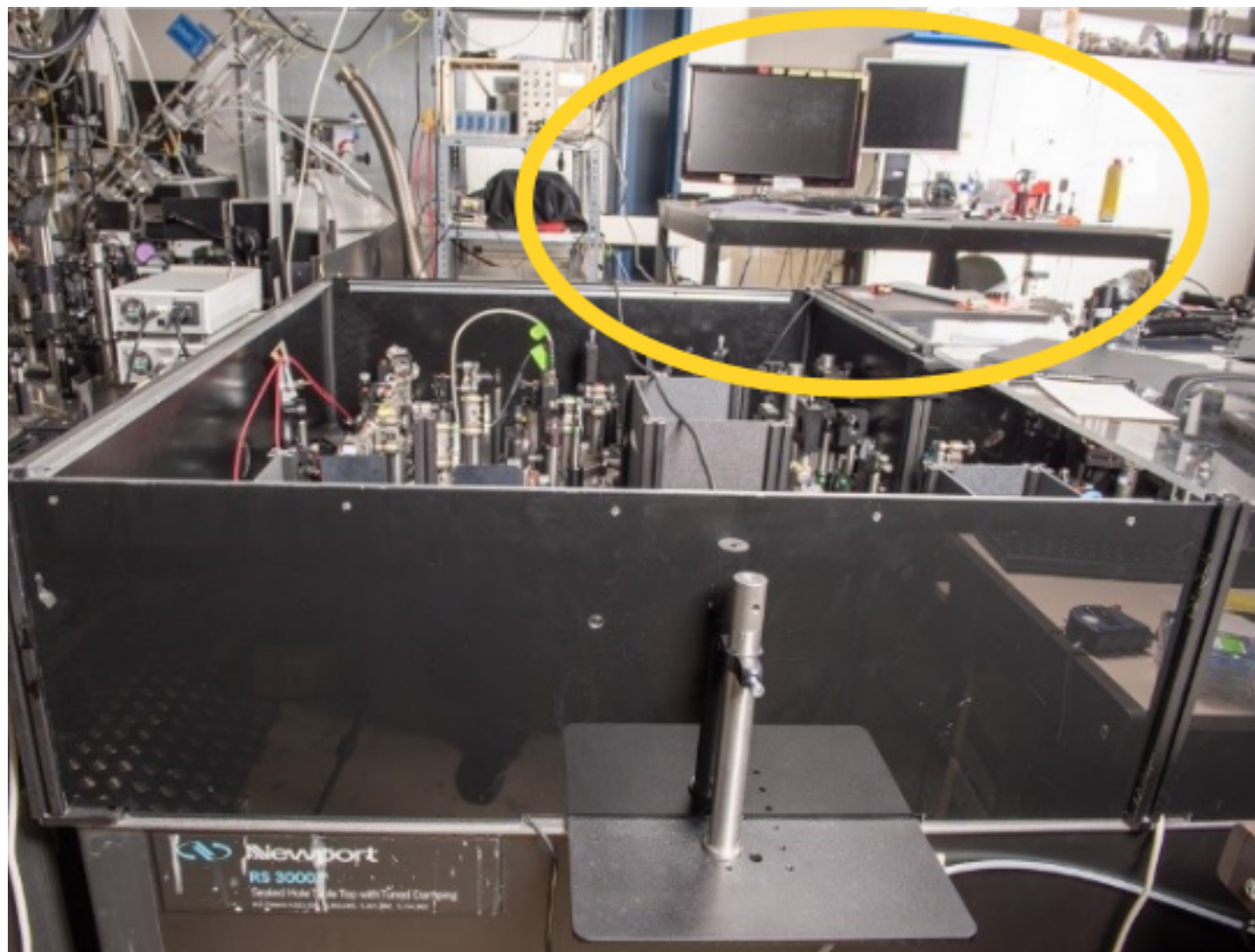

(3) Work with class 3B and 4 lasers @ EPFL, S T O P

- ▶ An area where laser is used should be delimited, and access to the area restricted (Camipro, key).
- ▶ A doorbell must be installed at the entrance of the laboratory. When the laser is in use, visitors must ring the bell and wait for permission before entering the laboratory.
- ▶ The lab door must close automatically and be equipped with a knob handle on the outside.



- ▶ To avoid that visitors are exposed to the beams, an entry way control (e.g. laser curtains) must be installed at the lab entrance, and must be kept closed when laser is in use.
- ▶ A signal lamp indicating laser in use must be placed above the door outside the laboratory. The bulb must be a white diode and the light must blink.

Video sequence: a visitor during laser alignment

If the embedded video doesn't function, please use the web link:

<https://video.epfl.ch/1113/1/10>

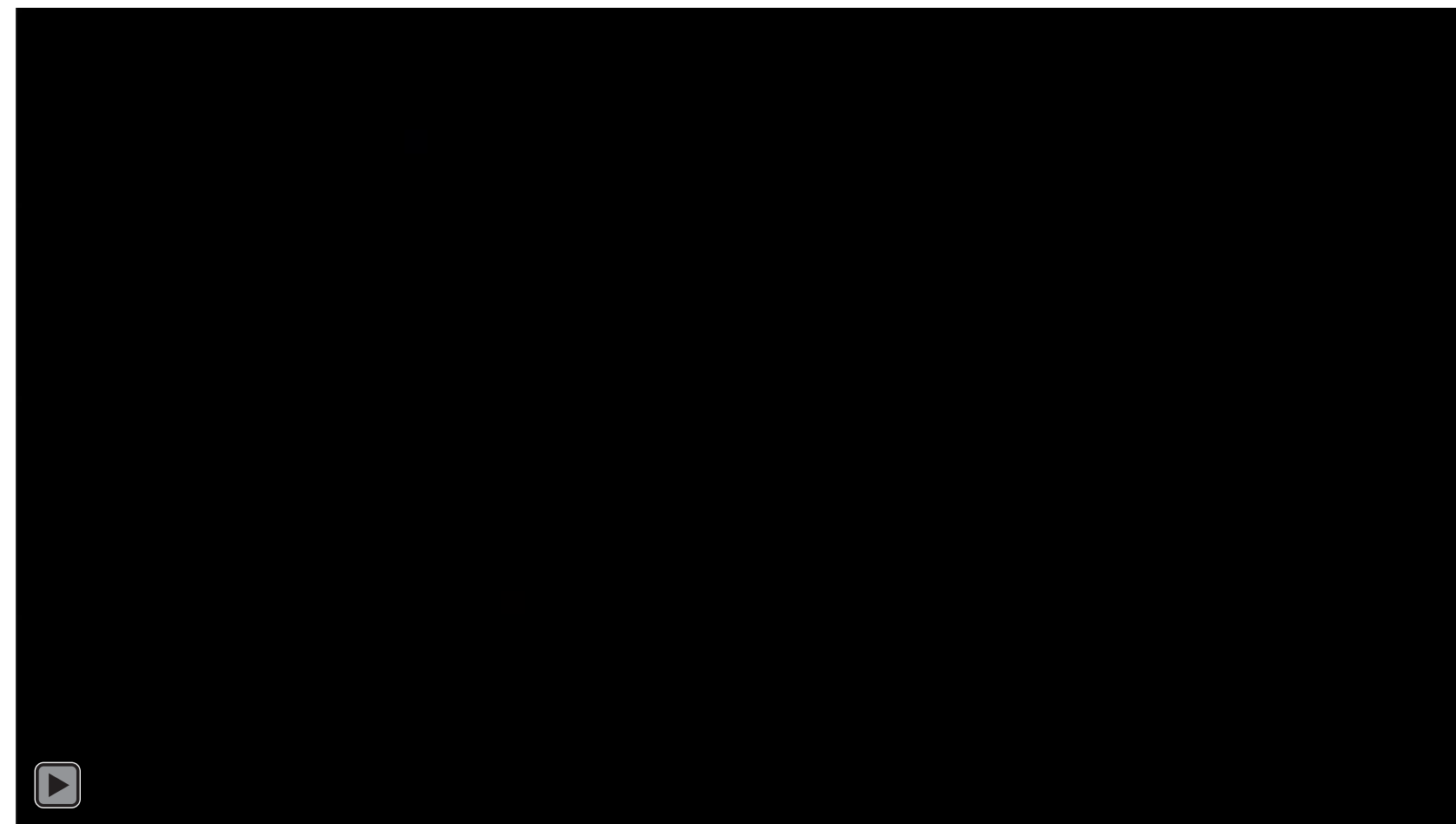

STOP: Personal Protection:

Applicable safety standard EN 207: Laser protection eyewear

- ▶ Defines the optical density required to protect the eye from a laser with a certain wavelength and power output.
- ▶ Objective: reduce the laser power below the MPE.
- ▶ The eyewear and its frame must **resist 5 seconds or 50 pulses.**
- ▶ **Do not look directly in the beam even with laser protection eyewear!**

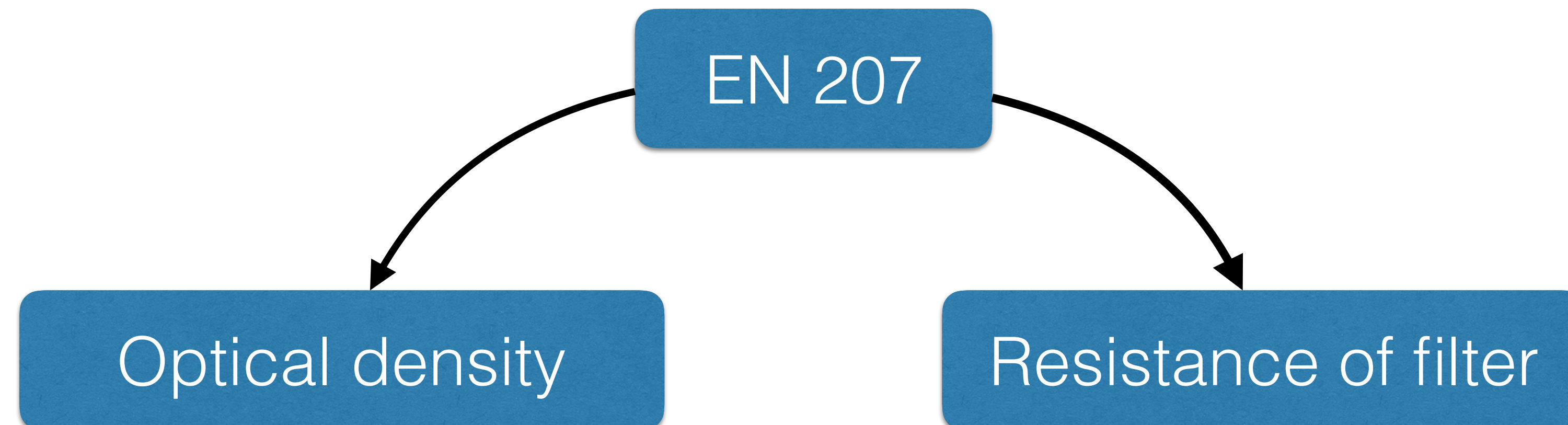

Optical Density

- ▶ All EN 207 rated eyewear will have an LB number for each operational mode for which it is rated.
- ▶ The LB number gives the minimum required optical density

Scale number	Minimum Optical Density	Ratio I_0/I for a given λ
LB1	1	10
LB2	2	100
LB3	3	1000
LB4	4	10000
LBn	n	10^n



Laser protection eyewear markings

Operational mode	MARKING Letter	Pulse length
Continuous	D	> 0.25 s
Pulsed	I	1 μ s – 0.25 s
Pulsed (Q-switched)	R	1 ns – 1 μ s
Pulsed (mode-coupled)	M	< 1 ns



Example

1064 D LB5 + IR LB7 GPT CE

1064 Wavelength in nm

D LB5 LB number 5 according to EN 207 for **continuous** mode lasers @ 1064 nm: Maximum 1MW/m²

IR LB7 LB number 7 according to EN 207 for **pulsed and short-pulsed** lasers @ 1064 nm: 50kJ/m²

GPT Manufacturer

CE CE Marking:89/686/EEC

(4) Work with class 3B and 4 lasers @ EPFL, STOP



- ▶ Compulsory: Lab head makes sure that personnel is trained for work with lasers and has a written evidence of that training (equipment specific training).
- ▶ All laser users must follow the present training and pass the quiz.
- ▶ Laser protective eyewear (**free of damage**) is to be worn by all personnel working with laser. Ideally the goggles should be marked with the name of the corresponding laser (photo above)
- ▶ The research group is in charge of purchasing laser protective eyewear. It is specific to lasers used and certified EN207.
- ▶ Either the vendor or SCC (scc@epfl.ch) can help to choose the goggles.
- ▶ If no ocular protection is available for a particular setup, only persons duly trained for this situation are authorized to enter the laboratory. The written orders are given to everyone by the laboratory head.

95% of laser accidents are...



Unanticipated eye exposure during alignment

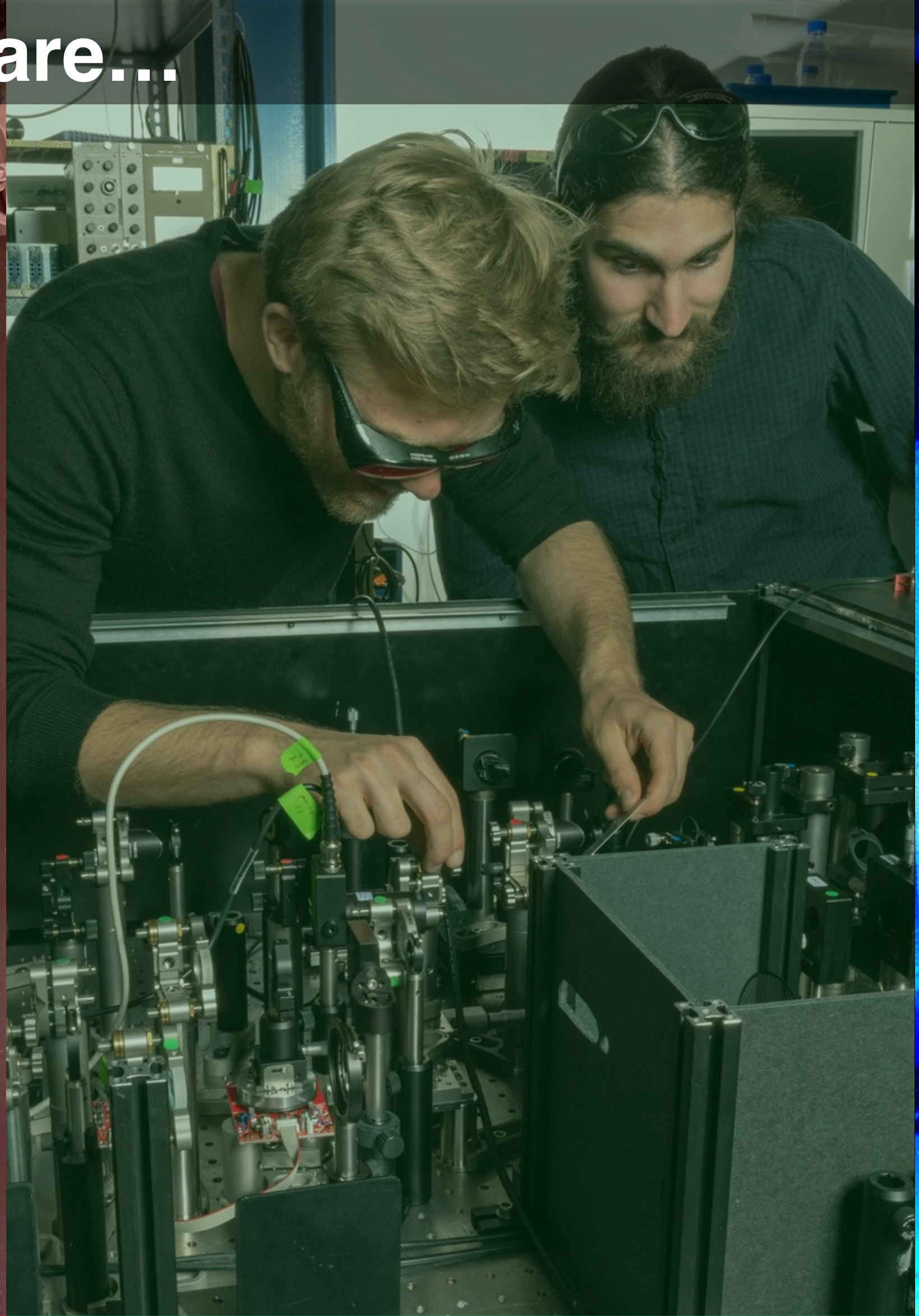

Available laser eye protection not used

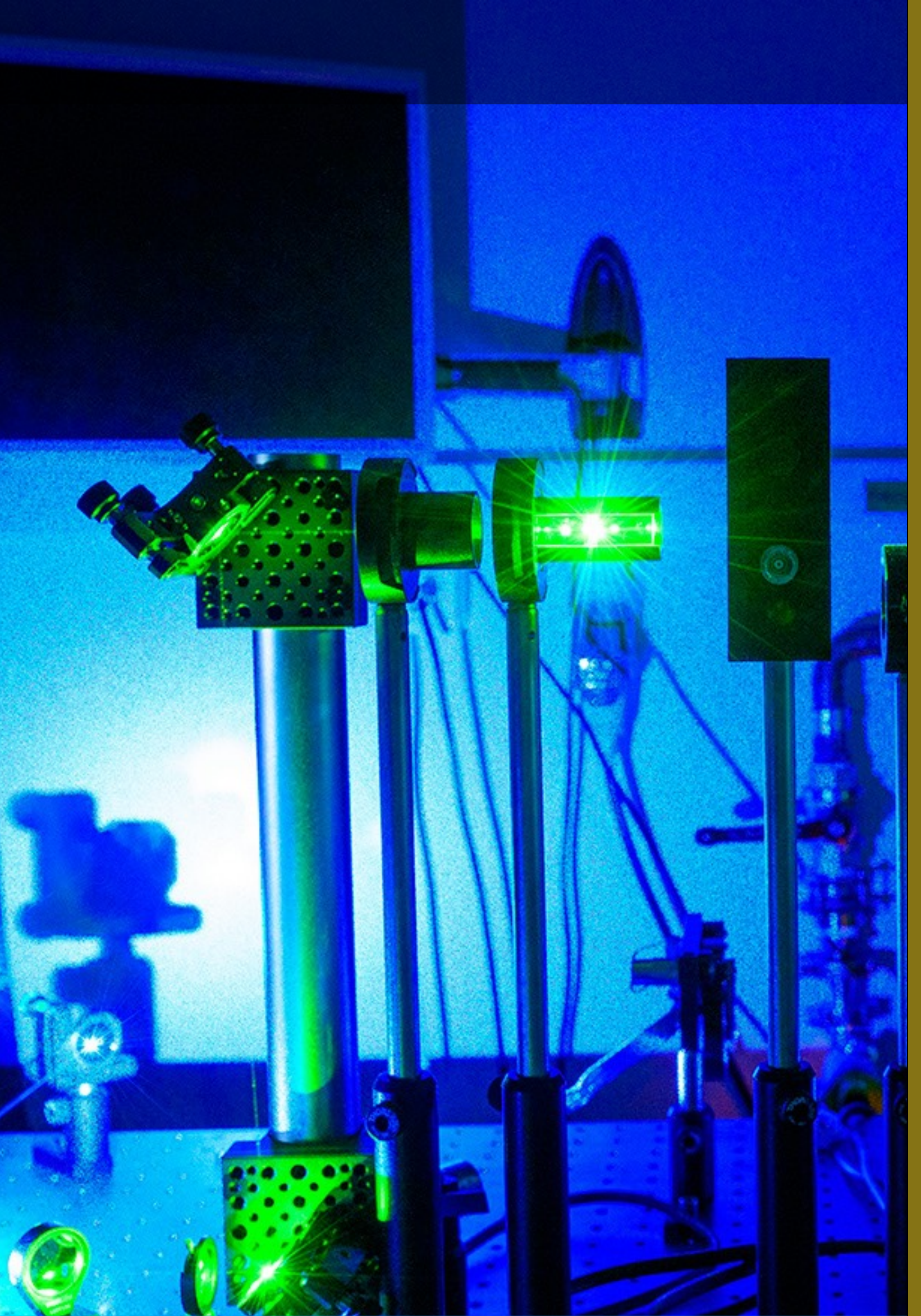

Misaligned optics and upwardly directed beams

5% = Others

What can I do when I have to align my visible laser?

Never remove your laser safety glasses when working with lasers above class 2!

There are so called alignment glasses available for this purpose

EN 208 for 400 – 700 nm **only**

- ▶ Suitable for aligning VIS lasers only.
- ▶ Do not absorb or reflect the laser radiation completely, the **radiation is only reduced** to values below

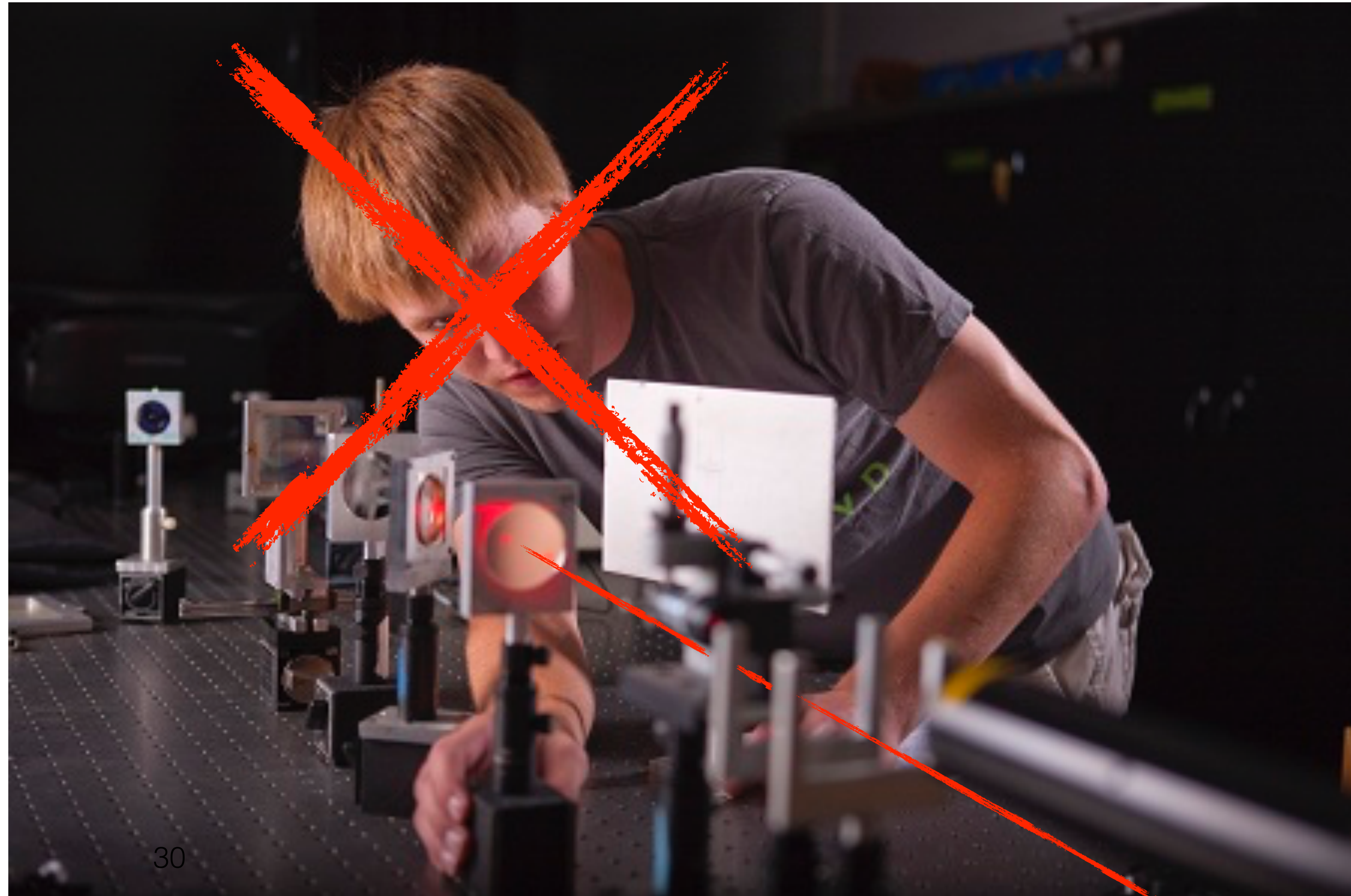

Golden rules of laser safety - (1)

- ▶ Do not look into a laser beam (or specular reflections)
- ▶ Keep the room lighting the brightest possible
- ▶ Locate and terminate all stray laser beams. Make sure they are terminated with a matt, diffusing beam dump which is capable of handling the power of the beam.
- ▶ Secure all optical components.
- ▶ Remove the watch, jewellery ...



Golden rules of laser safety - (2)

- ▶ Keep the beams horizontal.
- ▶ Do not look below the beam height.
- ▶ Use the adequate tools (non-reflecting).
- ▶ Maintain records of functions interruptions.
- ▶ Users must pass information to each other of any modification in the set-up (change of mirrors, ...) and the experimental conditions (change in wavelengths, ...)
- ▶ Do not forget the non optical risks (electrical, liquid nitrogen, chemical...)

What to do in case of accident with laser ?



- ▶ Turn the laser off (the fastest way is to press emergency stop button if there is one).
- ▶ Sit the injured person (do not lie).
- ▶ Call 115.
- ▶ Place a dry and sterile gauze on both eyes.
- ▶ Note the characteristics of the laser (wavelength and power) so they can be given to the first aid staff.
- ▶ First aid staff will normally take injured person to ophthalmic hospital.