

Low-power radio design for the IoT

Exercise 10 (27.05.2021)

Christian Enz

Swiss Federal Institute of Technology (EPFL), Lausanne, Switzerland

Problem 1 Pierce Oscillator

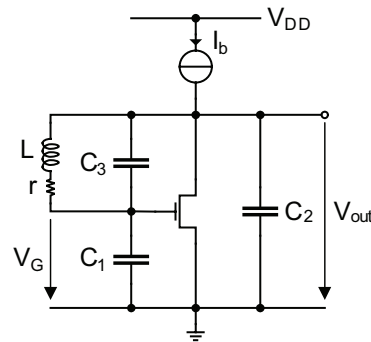

Figure 1: Pierce oscillator.

Design the Pierce oscillator shown in Fig. 1 for the following specifications:

$$f_0 = 2.4 \text{ GHz}, \quad C_2 = 1 \text{ pF}, \quad C_3 = 1 \text{ pF}, \quad Q_L = 10, \quad \mathcal{L}(\Delta\omega = 1 \text{ MHz}) = -112.37 \text{ dBc} \cdot \text{Hz}^{-1}$$

- Find the inductance value (choose C_1 to minimize the power consumption).
- Find the critical transconductance value.
- Find the critical current value assuming the transistor is biased in weak inversion (take $n = 1.3$).
- Find the output oscillation amplitude \hat{V}_{out} for the given phase noise specification. Assume that the transistor is biased in weak inversion and that the noise excess factor γ is equal to 1.2. If you haven't followed the course on phase noise, assume $\hat{V}_{\text{out}} = 100 \text{ mV}$ for the rest of the exercise.
- Find the bias current I_b for the specified amplitude assuming the transistor is biased in weak inversion (take $n = 1.3$).

Problem 2 Complementary cross-coupled oscillator

2.1 Oscillator analysis

Fig. 2 shows a complementary cross-coupled oscillator. In the first part of the problem we will derive expressions for quantities that will be used in the second part. All transistors are biased in weak inversion and have transconductances equal to G_m . Quality factor of the inductor is Q_L .

- Draw the small signal equivalent circuit.
- Derive the expression for the impedance seen from the inductor Z_c , and find $R_c = -\Re Z_c$ and $X_c = -\Im Z_c$.

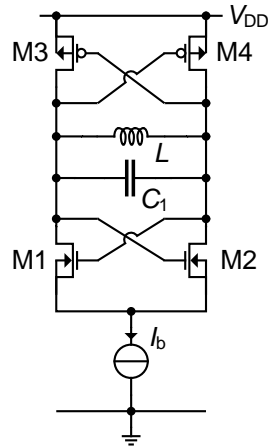

Figure 2: Complementary cross-coupled oscillator

- Derive the expression for the oscillation frequency ω_0 .
- Derive the expression for the G_{mcrit} .

2.2 Oscillator design

The derived expressions will now be used to design the oscillator with the following specifications:

$$f_0 = 2.4 \text{ GHz}, \quad C = 0.5 \text{ pF}, \quad Q_L = 10, \quad V_{\text{out}} = 325 \text{ mV}, \quad U_T = 25 \text{ mV}, \quad n = 1.3$$

Again, assume that all transistors are biased in weak inversion.

- Find the inductance value for the given oscillation frequency.
- Find the value of G_{mcrit} .
- Calculate the bias current needed to achieve the desired amplitude of the output voltage V_{out} . You can assume here that the condition $V_{\text{out}} \gg 2nU_T$ is fulfilled.