

# HW8: Link Layer - Solutions

COM-208: Computer Networks

## Reliable Internet

### Intermediate

If all the physical links in the Internet provided reliable data delivery, would TCP be unnecessary? Why or why not?

Although each link guarantees that an IP datagram sent over the link will be received at the other end of the link without errors, it is not guaranteed that IP datagrams will arrive at the ultimate destination in the proper order:

- With IP, datagrams in the same TCP connection can take different routes in the network, and therefore arrive out of order. TCP is still needed to provide the receiving end of the application the byte stream in the correct order.
- IP can lose packets in one of the intermediate hops due to routing loops or equipment failures. TCP is needed to assure that the packets have been received at the final destinations.

## L2 forwarding

### Basic

Consider an Ethernet IP subnet, where end-systems, labeled A through F, are star-connected to an Ethernet switch. The switch's forwarding table is initially empty. Then:

1. B sends a packet to E

2. E replies with a packet to B
3. A sends a packet to B
4. B replies with a packet to A.

Show the state of the switch's forwarding table before and after each of these events. For each event, identify the link(s) on which the transmitted frame will be forwarded.

The state of the switch table after each action is described in Table 1. Note: S refers to the Ethernet switch.

Action	Switch Table State	Link(s) frame is forwarded to	Exaplanation
B sends a frame to E	Switch learns interface corresponding to MAC address of B	AS, CS, DS, ES, and FS	Since switch table is empty, so switch does not know the interface corresponding to MAC address of E
E replies with a frame to B	Switch learns interface corresponding to MAC address of E	BS	Since switch already knows interface corresponding to MAC address of B
A sends a frame to B	Switch learns the interface corresponding to MAC address of A	BS	Since switch already knows the interface corresponding to MAC address of B
B replies with a frame to A	Switch table state remains the same as before	AS	Since switch already know the interface corresponding to the MAC address of A

Table 1: The state of the switch table

## Address allocation and ARP

### Basic

Consider three IP subnets interconnected by two routers (R1 and R2) as shown in Figure 1.

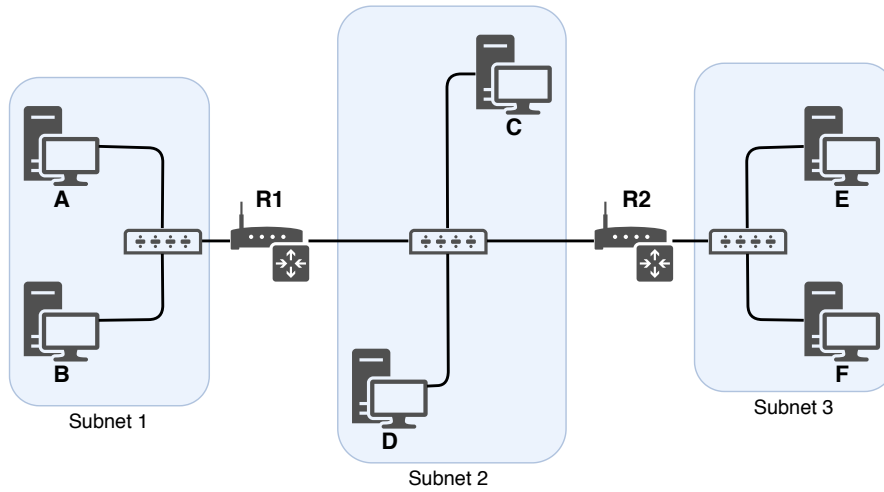

Figure 1: Three subnets, interconnected by routers

- Assign an IP address to each network interface of an end-system and router. Allocate the addresses from IP prefix 192.168.1.0/24 for Subnet 1, 192.168.2.0/24 for Subnet 2, and 192.168.3.0/24 for Subnet 3.

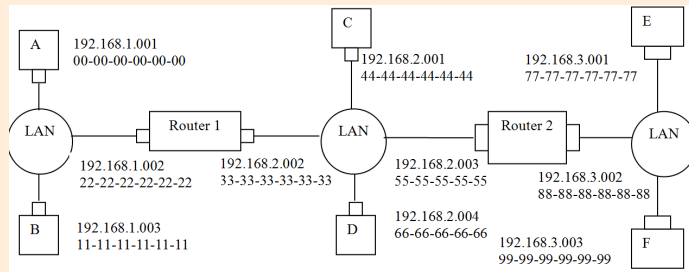

Figure 2: Assignment of IP and MAC addresses

- Assign a MAC address to each network interface.

See Figure 2.

- End-system E wants to send a packet to end-system B. List all the steps needed for the packet to be sent to B.

Assume that the forwarding tables of all switches already have entries for all MAC addresses, and all end-systems and routers already know each other's MAC addresses.

The steps taking place are the following:

1. Forwarding table in E determines that the datagram should be routed to interface 192.168.3.002.
2. E creates an Ethernet frame with Ethernet destination address 88-88-88-88-88-88 and source address 77-77-77-77-77-77.
3. Router 2 receives the frame and extracts the datagram. The forwarding table in this router indicates that the datagram has to be routed to 192.168.2.002.
4. Router 2 then sends an Ethernet frame with the destination address 33-33-33-33-33-33 and source address 55-55-55-55-55-55 via its interface with IP address of 192.168.2.003.
5. The process continues until the packet has reached Host B.

- Now assume that end-systems and routers do NOT previously know each other's MAC addresses (but the forwarding tables of switches still have entries for all MAC addresses). What additional step do we need for the packet to be sent to B.

ARP in E must now determine the MAC address of 192.168.3.002. Host E sends out an ARP query packet within a broadcast Ethernet frame. Router 2 receives the query and sends to Host E an ARP response with its MAC address. This ARP response packet is carried by an Ethernet frame with Ethernet destination address 77-77-77-77-77-77.

Then when Router 2 receives the datagram, it will broadcast an ARP request to determine the MAC address of 192.168.2.002 before it can route it to Router 1 (before step 4 in previous question).

Router 1 will do the same and send an ARP request to get the MAC address of B.

### Intermediate

Assume we changed the topology as shown in figure 3. We replace the router between subnets 1 and 2 with a switch S1, so now these subnets will become one subnet "subnet1-subnet2-merged". We also label the router between subnets 2 and 3 as R1.

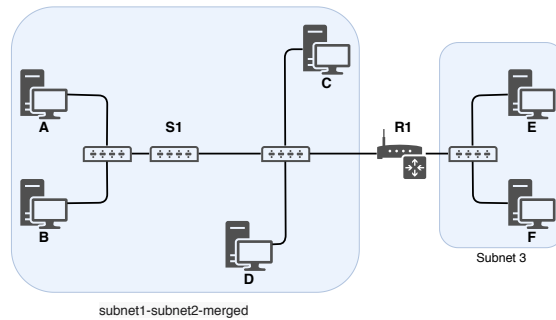

Figure 3: Three subnets, interconnected by switch or router

- End-system E wants to send a packet to end-system F. Is router R1 involved in forwarding the datagram? What are the source/destination MAC/IP addresses in the packet's Ethernet and IP headers?

No. E can check the subnet prefix of Host F's IP address, and then learn that F is on the same IP subnet. Thus, E will not send the packet to the default router R1. Ethernet frame from E to F:

Source IP = E's IP address  
 Destination IP = F's IP address  
 Source MAC = E's MAC address  
 Destination MAC = F's MAC address

- End-system E wants to send a packet to end-system B. E does not know B's MAC address. Will E send out an ARP request (before sending the actual packet) to learn B's MAC address? What are the source/destination MAC/IP addresses in the actual packet's Ethernet and IP headers?

No, because they are not on the same IP subnet. E can find this out by checking B's IP address. However, E will still send an ARP request but to learn R1's MAC address and not that of B.

Ethernet frame from E to R1:  
 Source IP = E's IP address  
 Destination IP = B's IP address  
 Source MAC = E's MAC address  
 Destination MAC = The MAC address of R1's interface connecting to Subnet 3

- End-system A wants to send a packet to end-system B. Switch S1's forwarding table contains entries with B's and R1's MAC addresses only. Neither A nor B know each other's MAC address. Hence, A sends out an ARP request message (before sending the actual packet).

1. What will S1 do when it receives A's ARP request?
2. Will router R1 also receive this ARP request? If so, will R1 forward the ARP request to Subnet 3?

When end-system B receives this ARP request, it will send back an ARP response.

3. Before sending this ARP response, does B need to send its own ARP request to learn A's MAC address?
4. What will S1 do when it receives B's ARP response?

1. Switch S1 will forward the frame containing the ARP request (MAC destination 0xFF:FF:FF:FF:FF) on the port on the right side. At the same time S1 will update its forwarding table to include an entry for Host A: associate MAC A with the port on the left side.
2. Yes, router R1 also receives this ARP request message, but R1 won't forward the message to Subnet 3.
3. when B receives the ARP request, it won't send ARP query message asking for A's MAC address, as this address can be obtained from A's query message.
4. Switch S1 will not receive the ARP response from B, because the left most switch in Figure 1 already knows that it has to forward this to the link towards A and not towards S1 (its forwarding table already includes an entry for Host A).

## A wrap-up

### Intermediate

You walk into a room, connect your laptop to an Ethernet outlet, and type in your web browser a URL of a web page. List all the messages/packets that you expect your laptop to send or receive until you download the web page. Assume that your laptop is configured with the IP address of a local DNS server, as well as the IP address of a default gateway (a router through which traffic from your laptop will exit the local IP subnet).

Since your computer's ARP cache is initially empty, your computer will use ARP protocol to get the MAC addresses of the first-hop router and the local DNS server.

Your computer will first query the local DNS server to find the IP address of the Web page you would like to download.

Once your computer has the IP address of the Web page, then it will establish a TCP connection and send out a HTTP request via the first-hop router (assuming the Web server does not reside inside the local network). The HTTP request message will be segmented and encapsulated into TCP packets, and then further encapsulated into IP packets, and finally encapsulated into Ethernet frames. Your computer sends the Ethernet frames destined to the first-hop router. Once the router receives the frames, it passes them up to the IP layer, checks its routing table, and then sends the packets to the next-hop (the interface corresponding to the next-hop in the routing table). Then your IP packets will be routed through the Internet until they reach the Web server.

The server hosting the Web page will send back the Web page to your computer via HTTP response messages. Those messages will be encapsulated into TCP packets and then further into IP packets. Those IP packets follow IP routes and finally reach your first-hop router, and then the router will forward those IP packets to your computer by encapsulating them into Ethernet frames.