

Artificial Neural Networks: RL3

Policy Gradient Methods

Wulfram Gerstner

EPFL, Lausanne, Switzerland

Part 1: First steps toward deep reinforcement learning

Objectives of this lecture:

- **basic idea of policy gradient: learn actions, not Q-values**
- **log-likelihood trick: getting the correct statistical weight**
- **policy gradient algorithms**
- **why subtract the mean reward?**
- **reinforce with baseline (see actor critic)**

Reading for this week:

**Sutton and Barto, Reinforcement Learning
(MIT Press, 2nd edition 2018, also online)**

Chapter: 13.1-13.5

Background reading: none

Review: Artificial Neural Networks for action learning



Where is the supervisor?
Where is the labeled data?

Replaced by:

'reward or value of action'

- 'goodie' for dog
- 'success'
- 'compliment'

BUT:

Reward is rare:

'sparse feedback' after
a long action sequence

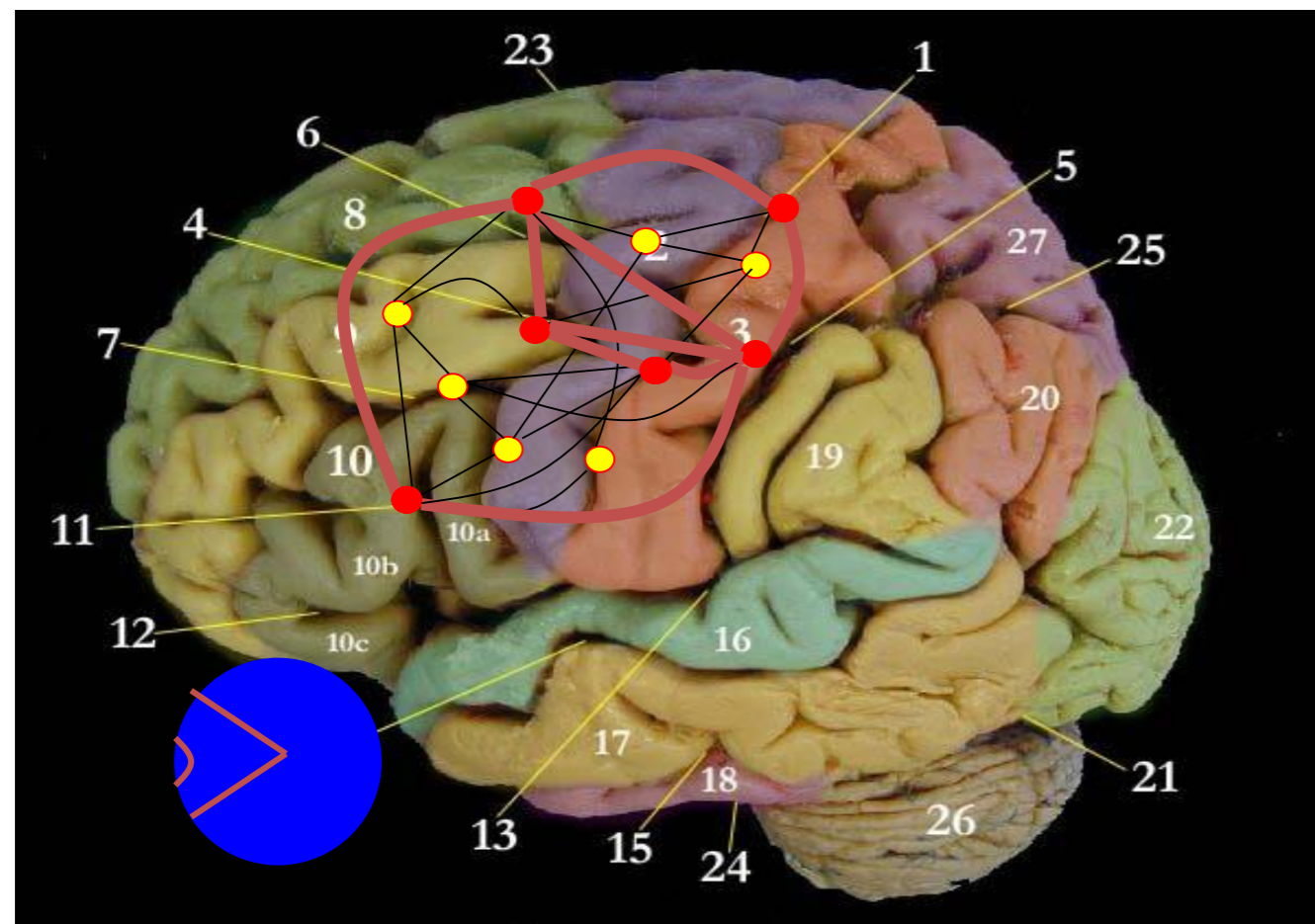

First steps toward Deep reinforcement learning

Chess

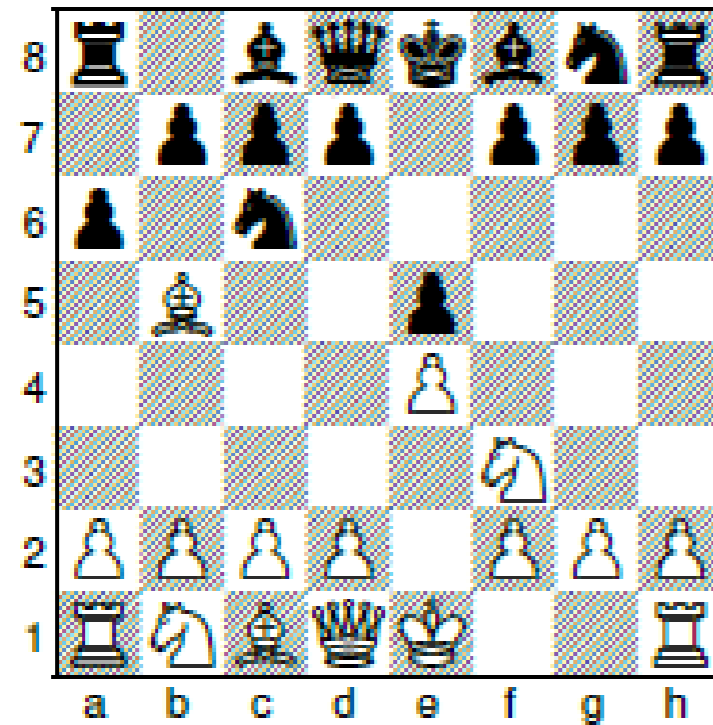

Artificial neural network
(*AlphaZero*) discovers different
strategies by playing against itself.

In Go, it beats Lee Sedol

Go

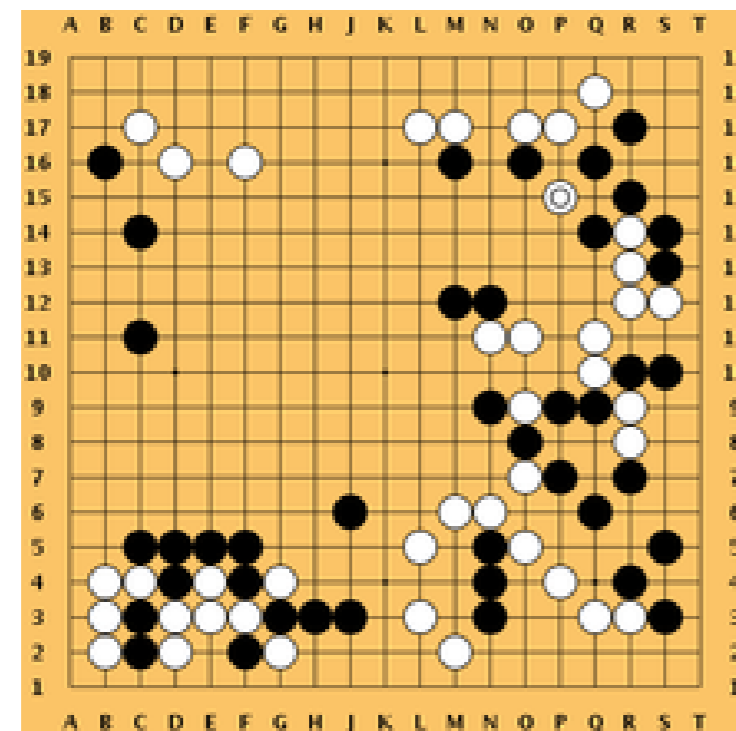

Backprop for deep Q-learning

action and Q-values:

Advance king

output ↑ ↑ ↑ ↑ ↑

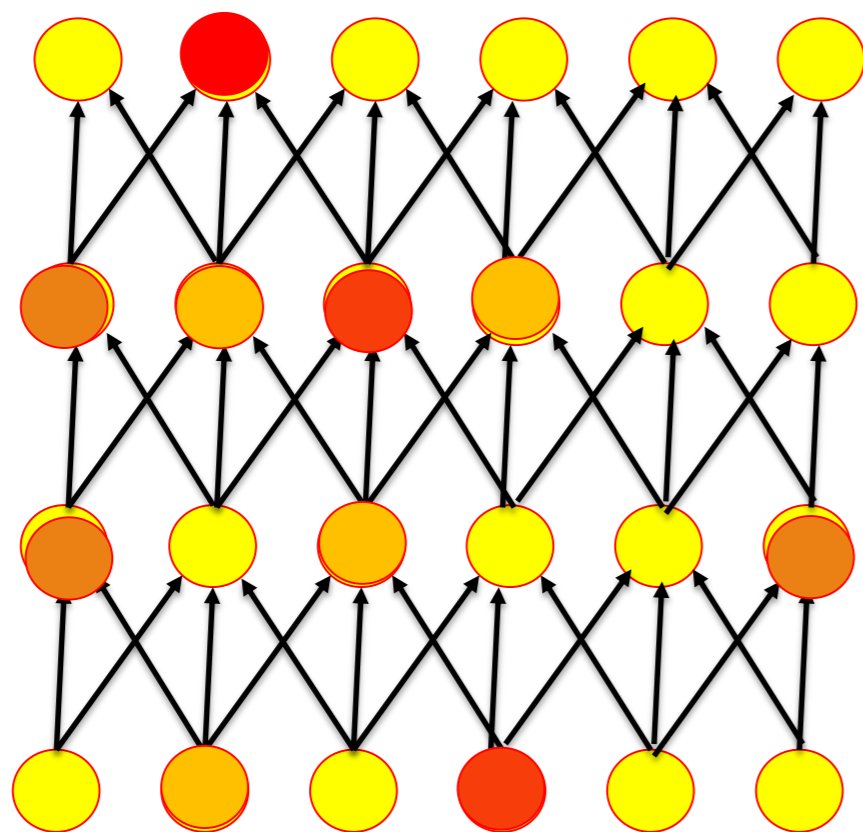

input ↑ ↑ ↑ ↑ ↑

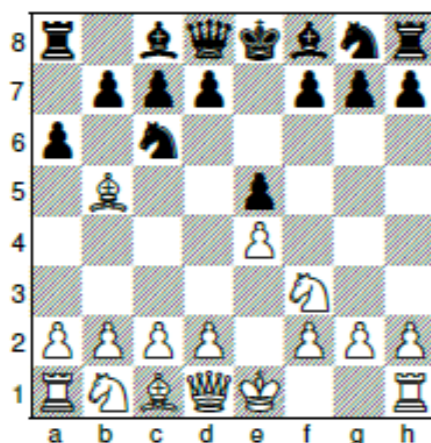

Outputs are Q-values
→ actions are easy to choose

For example:

Softmax strategy: take **action a'**
with prob

$$P(a') = \frac{\exp[\beta Q(a')]}{\sum_a \exp[\beta Q(a)]}$$

(previous slide)

Last week we have seen that we can model Q-values in continuous state space as a function of the state s , and parameterized with weights w .

But in fact, a model of Q-values also works when the input space is discrete, such as it is in chess. Suppose that each output corresponds to one action (e.g. one type of move in chess).

We can use a neural network where the output are the Q-values of the different actions while the input represents the current state s .

Thus, an output unit n represents $Q(a_n, s)$.

Backprop for deep Q-learning

(Backprop = gradient descent rule in multilayer networks)

action and Q-values:

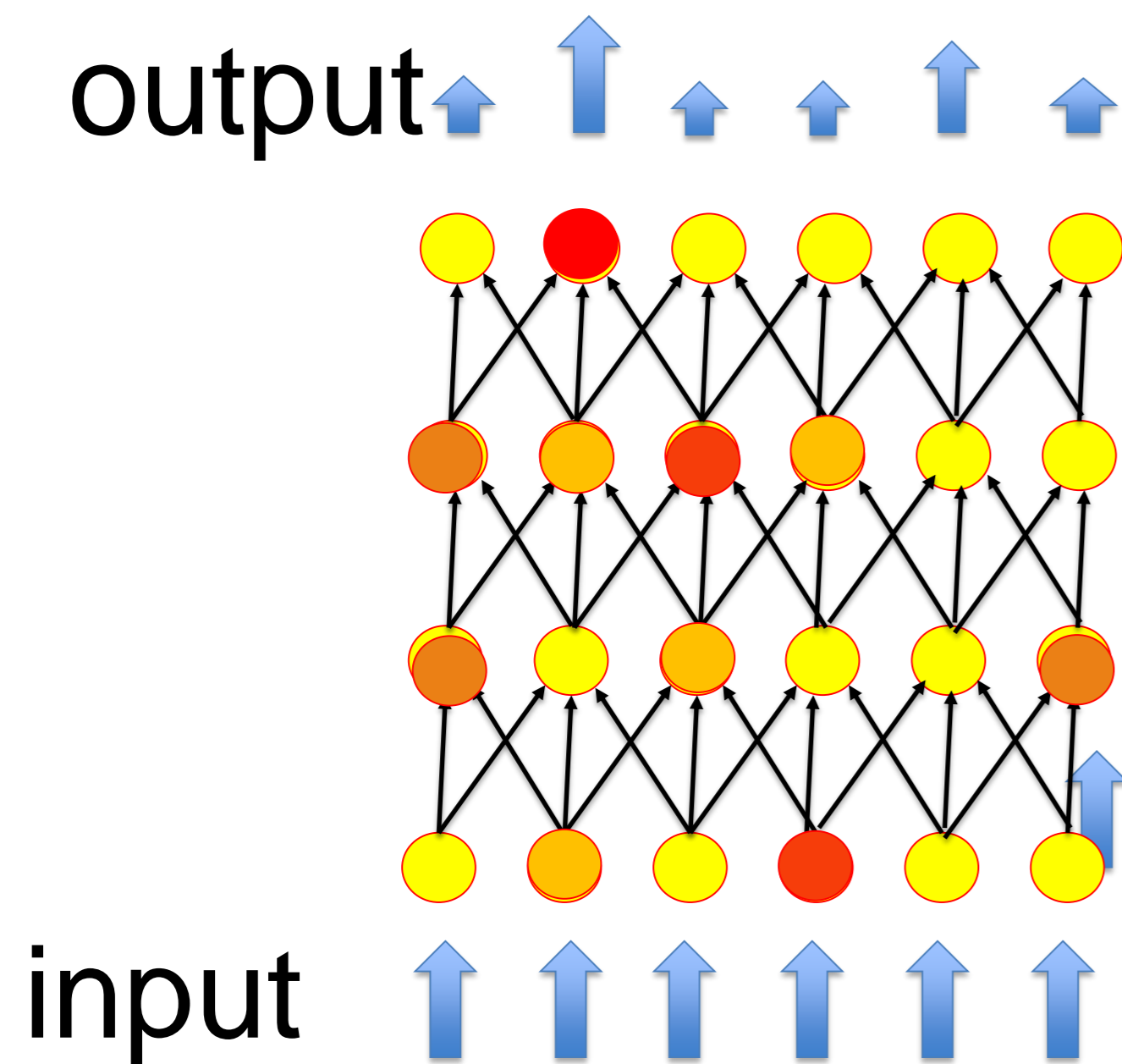

**Neural network parameterizes Q-values as a function of continuous state s .
One output for each action a .
Learn weights by playing against itself.**

Error function for SARSA

$$E = 0.5 [r + \gamma Q(s',a') - Q(s,a)]^2$$

(previous slide)

Suppose that each output corresponds to one action (e.g. one type of move in chess). Parameters are now the weights of the artificial neural network.

Actions are chosen, for example, by softmax on the Q-values in the output.

Weights are learned by playing against itself – doing gradient descent on an error function E .

Last week we finished by stating the error function:

$$E = 0.5 [r + \gamma Q(s',a') - Q(s,a)]^2$$

This error function will depend on the weights w (since $Q(s,a)$ depends on w). We can change the weights by gradient descent on the error function. This leads to the Backpropagation algorithm of 'Deep learning' (will be discussed next week).

Error function for continuous input representation

Consistency condition of Bellman Eq.

$$Q(s, a) = \sum_{s'} P_{s \rightarrow s'}^a \left[R_{s \rightarrow s'}^a + \gamma \sum_{a'} \pi(s', a') Q(s', a') \right]$$

On-line consistency condition
(should hold on average)

$$Q(s, a) = r + \gamma Q(s', a')$$

yields (online) Error function

target

$$E(\mathbf{w}) = \frac{1}{2} [r_t + \gamma Q(s', a' | \mathbf{w}) - Q(s, a | \mathbf{w})]^2$$

ignore

take gradient w.r.t \mathbf{w}

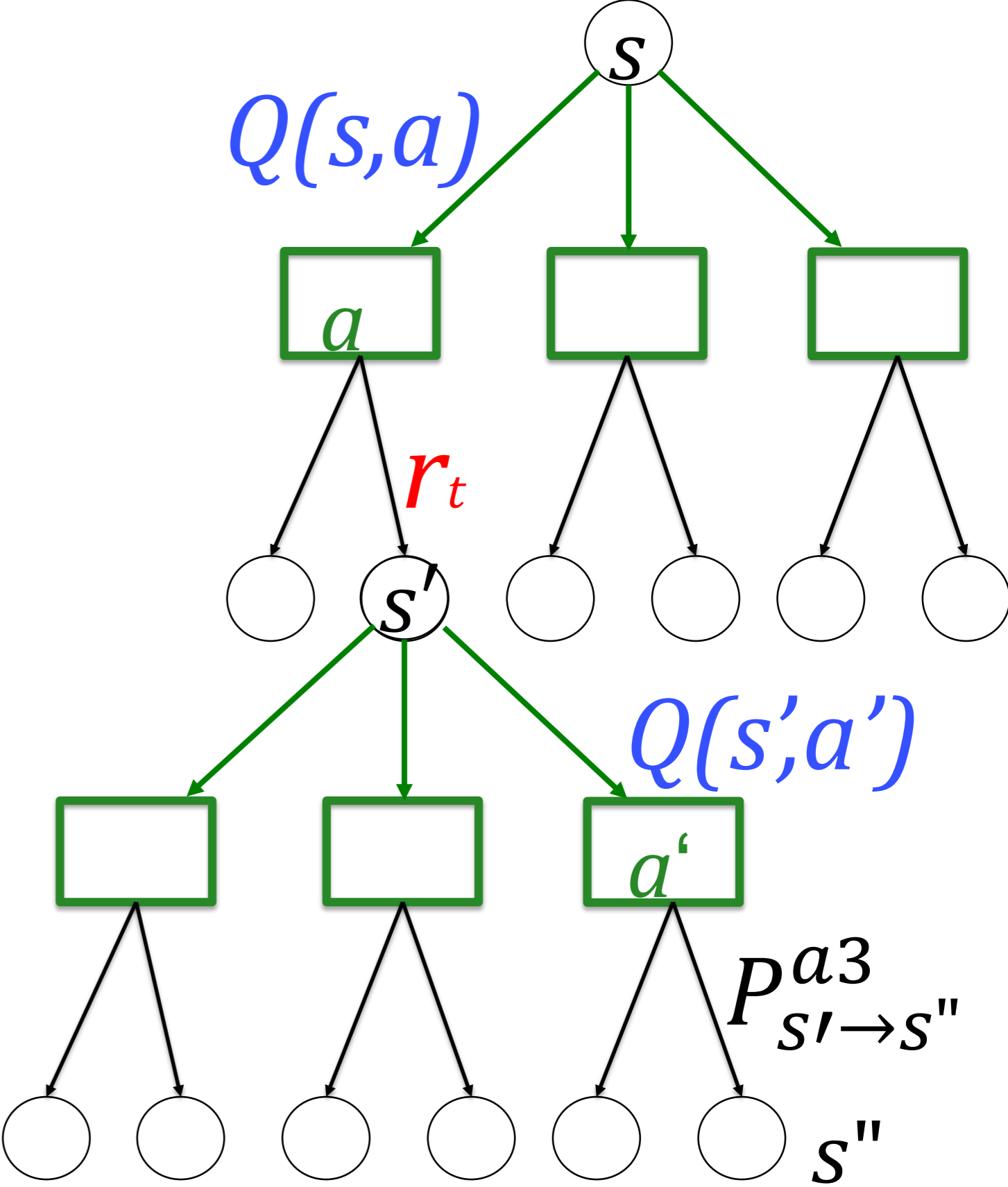

(previous slide)

During the discussion of the Bellman equation and SARSA, we stated repeatedly that essentially we formulate a consistency condition.

$$Q(s,a) = r + \gamma Q(s',a')$$

Where the equality sign has to be interpreted as 'should ideally on average be close to' and the right hand side is the 'target of learning'

The quadratic error function E measures how close we are to such an ideal case. This error function works not just for continuous state space, but also for a discrete state space such as in chess.

IMPORTANT NOTE: Since the 'target of learning' should be considered as momentarily fixed, we optimize the error function by taking the derivative of E with respect to the w in $Q(s,a)$ but ignore that the target $Q(s',a')$ also depends on w . In other words, during the optimization step we consider $Q(s',a')$ as fixed.

Taking the derivative with fixed target yields SARSA; see Exercise 5 of RL2.

Taking the derivative with fixed target is also called: semi-derivative.

Deep Neural Network for Value function

Action: move piece by epsilon greedy so as to increase V-value in each step

output: V-values:

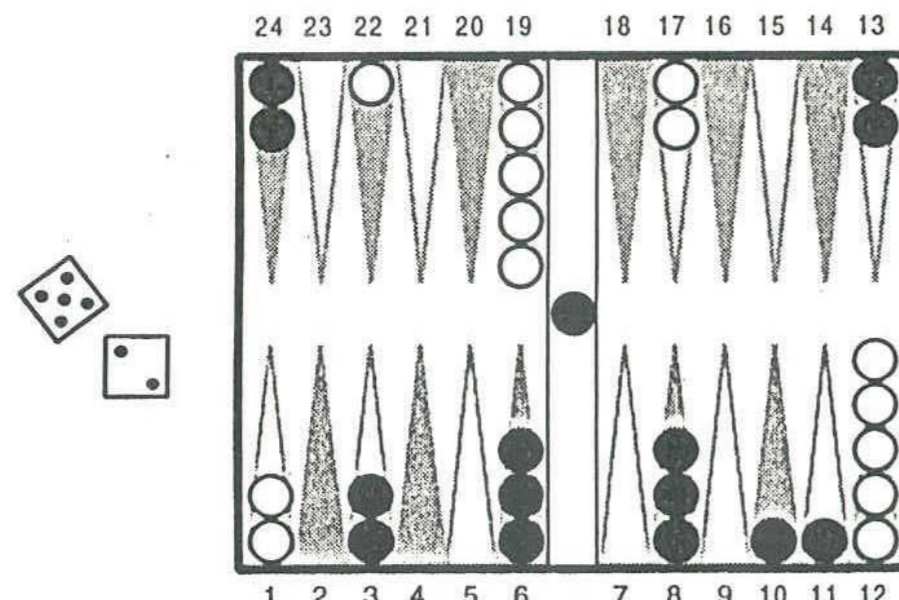
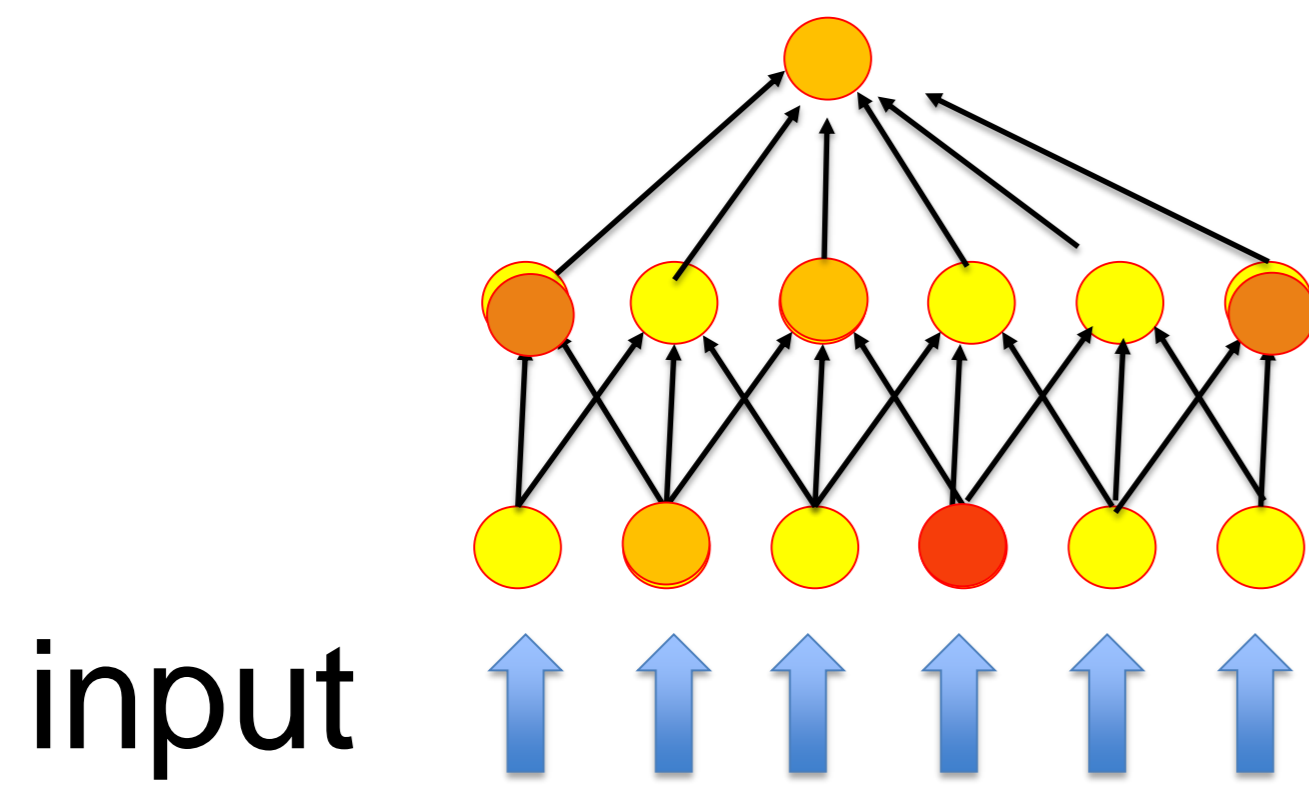

- **Neural network parameterizes V-values as a function of state s.**
- **One single output.**
- **Learn weights by playing against itself.**
- **Minimize TD-error of V-function**
- **use eligibility traces**

TD-Gammon

Tesauro, 1992, 1994, **1995**, 2002

(previous slide)

The very same ideas can also be applied to learning the V-values, instead of Q-values. The advantage is that we have one single output. The disadvantage is that we need to look ahead (next possible states) to choose the action. But for games with a small number of 'possible next states' this is not a problem.

The analogous Bellman equation for the V-values leads to a consistency condition characterized by an error function

$$E(\mathbf{w}) = \frac{1}{2} [r_t + \gamma V(s'|\mathbf{w}) - V(s|\mathbf{w})]^2$$

Eligibility traces enable to connect the reward at the end to states several steps before.

Neural networks to model input space

- for control problems, input space is naturally **continuous**

Example: moon lander

Aim: land between poles

→ generalize to neighboring states

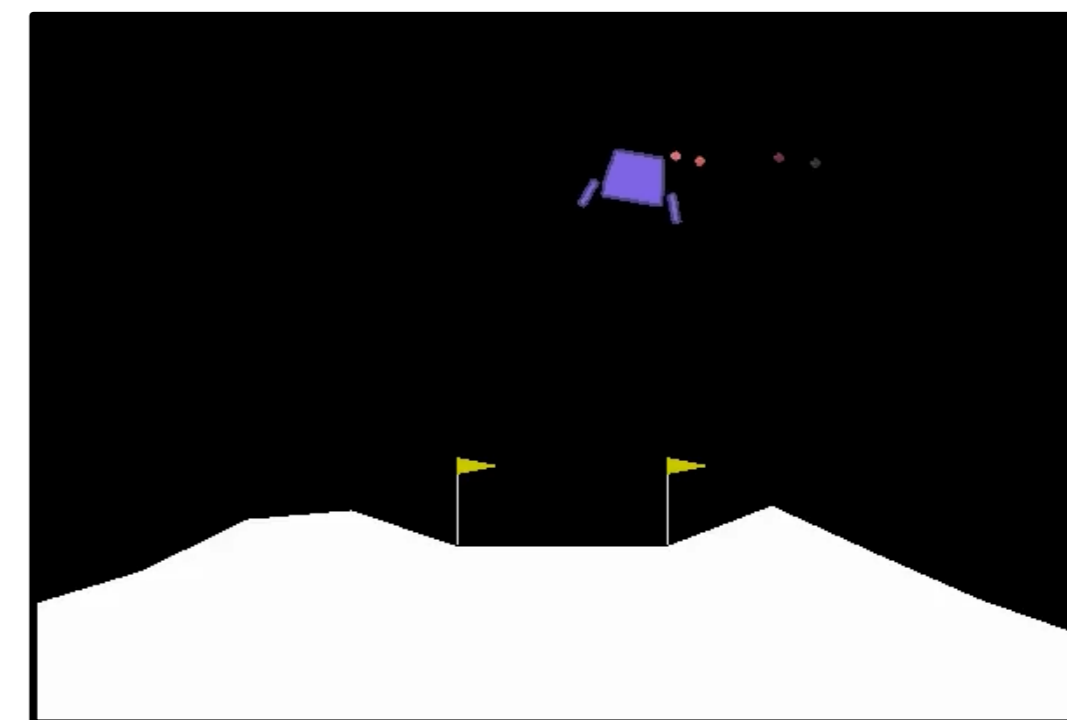

- for **discrete** games, the input space often too big

→ generalize via hidden states in neural networks

Chess

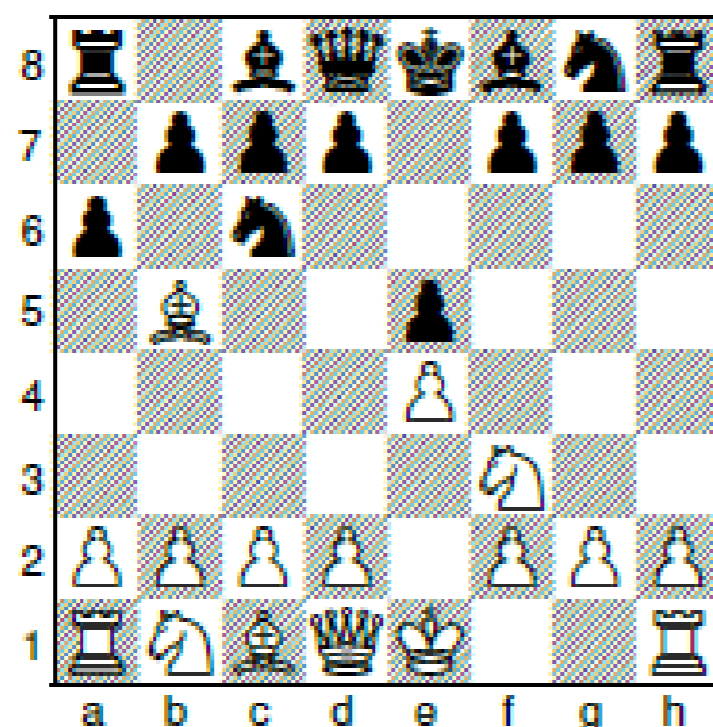

Go

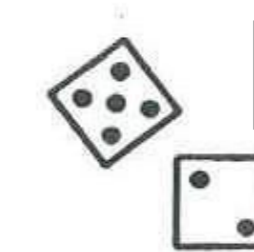
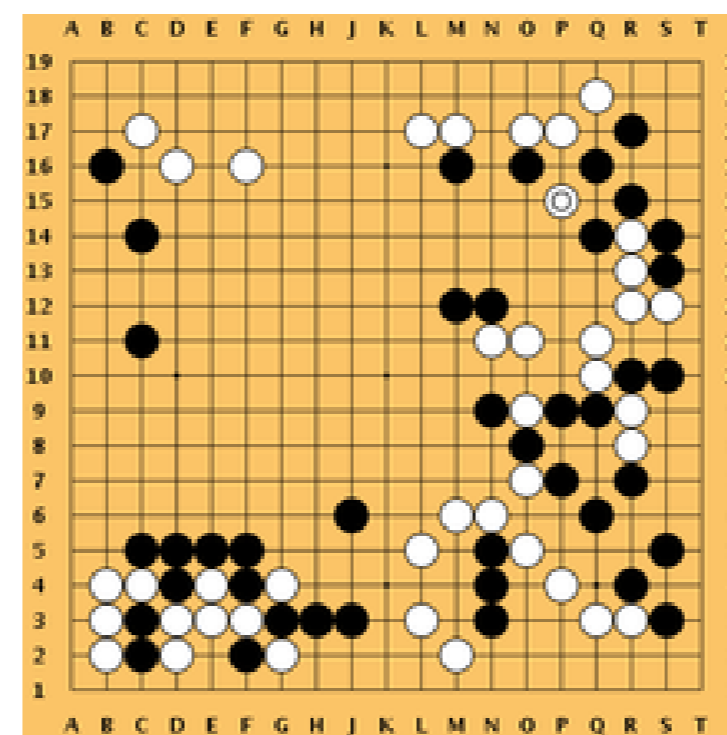

Backgammon

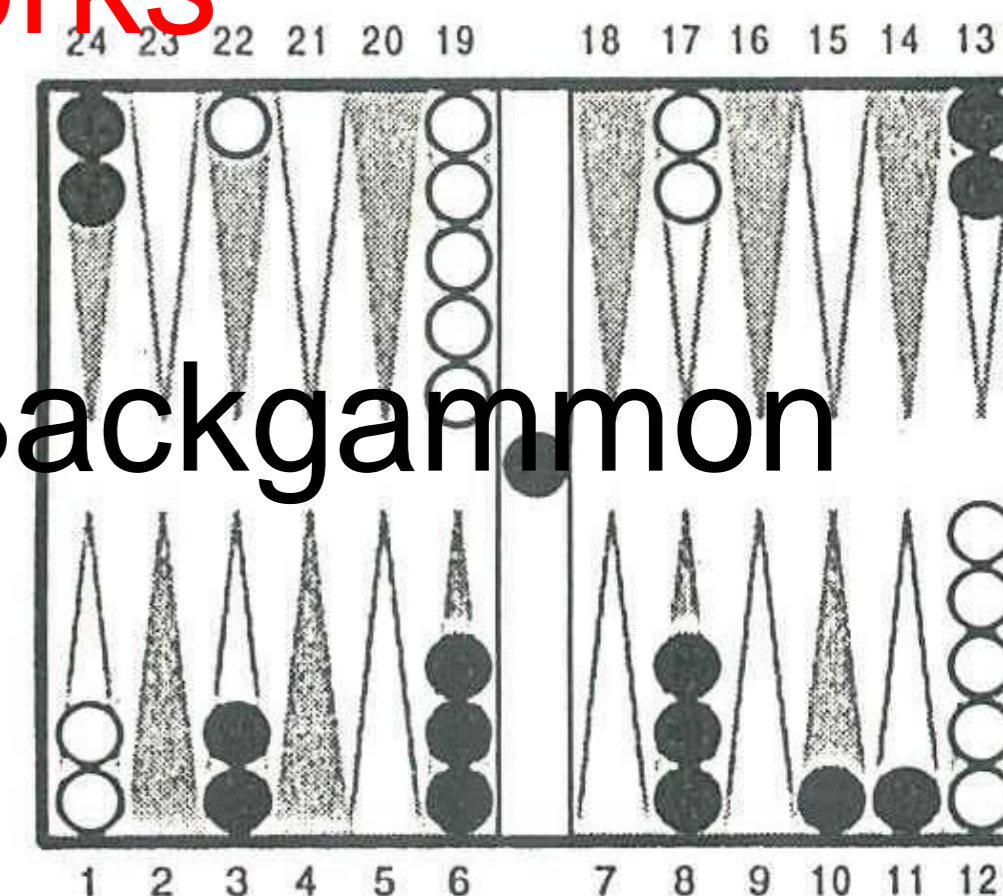

(previous slide)

Why is it useful to use a continuous (as apposed to tabular) description of input space even in cases where the input is naturally discrete such as in games?

The reason is that describing Q-values as a SMOOTH function of the input enables generalization. Hidden layers of neural networks are able to extract compressed representations of the input space that introduce heuristic but useful notion of what it means that two states are 'similar' or 'neighbors'.

Related ideas have been used in many other applications, beyond chess backgammon or Go. We will study some of these later in this class.

TD learning where Q-values are V-values are described by a smooth function, is also called 'function approximation in TD learning'. The family of functions can be defined by the parameters of a Neural Network or by the parameters of a linear superposition of basis functions.

Summary: Deep Neural Network for TD learning

In all TD learning methods

(includes n-step SARSA, Q-learning, TD(λ))

- V-values OR Q-values are the central quantities
- actions are taken with softmax, greedy, or epsilon-greedy policy **derived from Q-values/V-values**

(previous slide)

In the previous two weeks, we have seen many different versions of TD learning. This includes SARSA and Q-learning, TD learning, with eligibility traces (decay factor $\lambda < 1$) or without, or n-step V-learning.

In all of these algorithms the V-values or Q-values are the central quantities. We first learn the V-values (or Q-values) and then the policy is based on these values.

TD learning versus Policy Gradient

Aim of this lecture:

- learn actions directly
- no need for Q-value estimation

→ Policy Gradient

→ A glimpse into Deep Reinforcement Learning

(previous slide)

The question for today is: Can we learn directly the policy – without taking the detour via the Q-values or V-values? The answer is yes and leads to a family of methods that are called ‘policy gradient’.

A secondary aim is to give a preparation of modern developments in Deep Reinforcement Learning.

Artificial Neural Networks

Policy Gradient Methods

Wulfram Gerstner

EPFL, Lausanne, Switzerland

Part 2: Basic idea of policy gradient

1. First steps toward deep reinforcement learning
2. **Basic idea of policy gradient**

(previous slide)

Let us start with the reasons to work with policy gradients rather than V-values or Q-values.

Disadvantages of Q-learning, SARSA, or TD-learning

- For **continuous states**, **function approximation** is necessary (which is potentially unstable).
- Even in fully observable (Markov) settings, off-policy TD algorithms (e.g. Q-learning) can diverge using **function approximation**.
- In **partially observable** environments (non-Markov), TD algorithms are problematic
- **Continuous actions** are difficult to represent using TD methods.

World is not a Markov Process

World is not fully observable

World is not tabular (not discrete states)

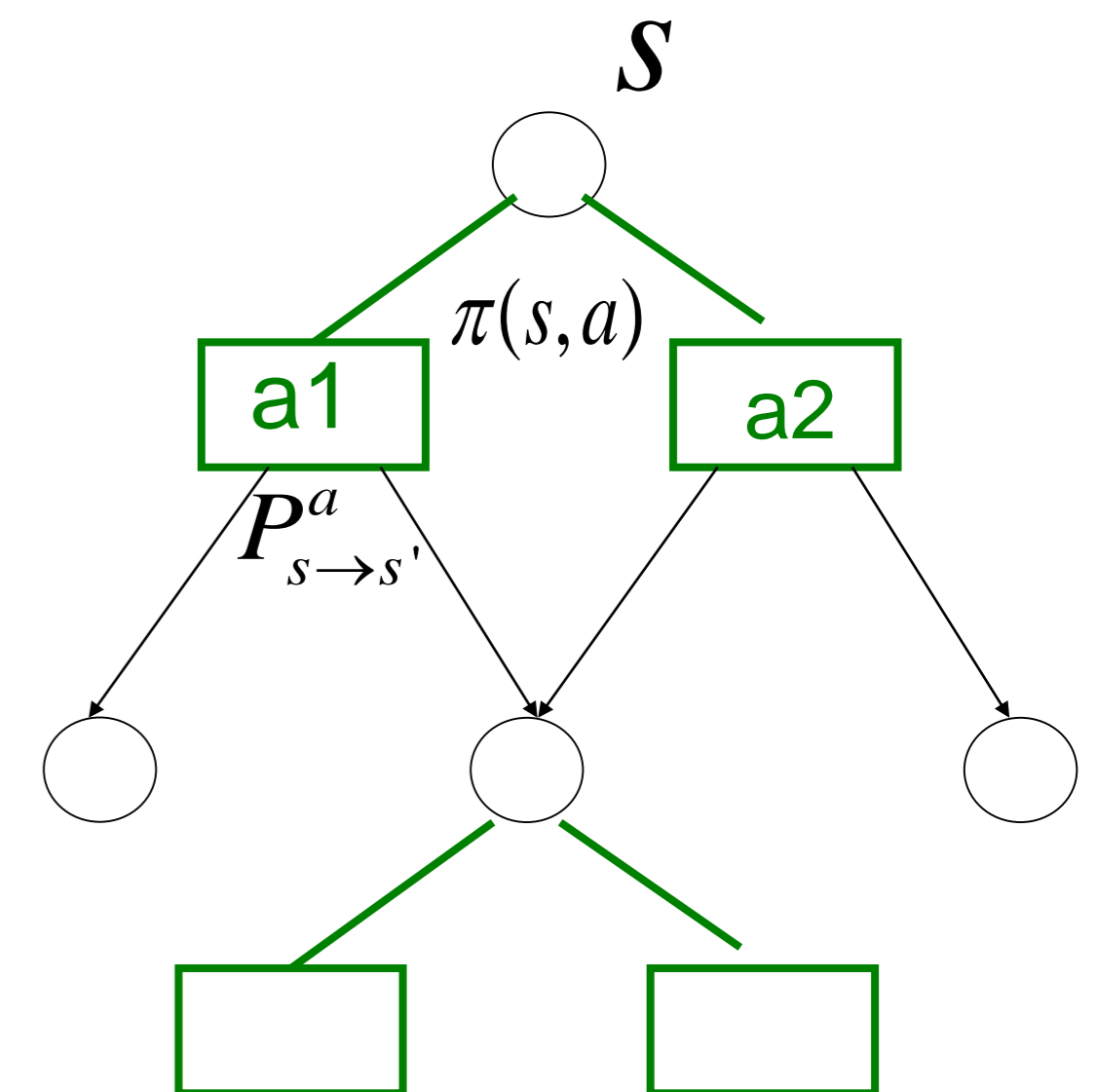

(previous slide)

Q-values and V-values work best in an environment that has Markov properties, in particular discrete, distinguishable states, and transition probabilities between these states. Building V-values (or Q-values) then means building a table of these states (or state-action pairs).

But the world is not Markovian; however, if we use the Markovian assumptions in an environment where this is not true, then there is no guarantee that these algorithms converge.

Policy Gradient methods: basic idea

- Forget Q-values
- Optimize directly the reward
- Associate actions with stimuli stochastically

Table in Q-learning:
(state,action) \rightarrow Q

	a_1	a_2	a_3
s_1	$Q(s_1, a_1)$	$Q(s_1, a_2)$	
s_2	$Q(s_2, a_1)$		
s_3			
s_4			

Table in Policy gradient:
state \rightarrow Prob(action|state)

	a_1	a_2	a_3
s_1	0.1	0.8	0.1
s_2	0.75	0.1	0.15
s_3	0.01	0.02	0.97
s_4	0.5	0.5	0.0

(previous slide)

Difference between Q-learning and policy gradient:

In Q-learning you build a table of $Q(s,a)$ for each state-action pair. Then you derive the policy from this (e.g., epsilon-greedy).

In policy gradient you learn directly the probability of taking action a in state s . Since these are probabilities, they must sum to one.

Policy Gradient methods: basic idea

- Forget Q-values
- Optimize directly the reward
- Associate actions with stimuli using a stochastic policy
- **Change parameters so as to maximize rewards**

stochastic policy

$$\pi(a|s, \theta)$$

parameter

Table in Policy gradient: $\pi(a|s, \theta)$
state \rightarrow Prob(action|state, parameters)

	a_1	a_2	a_3
s_1	0.1	0.8	0.1
s_2	0.75	0.1	0.15
s_3	0.01	0.02	0.97
s_4	0.5	0.5	0.0

(previous slide)

The basic ideas are now that

(i) these probabilities will depend on a set of parameters θ

(ii) these probabilities can be directly interpreted as the policy $\pi(a|s, \theta)$

Note sometimes the policy is written with parameters suppressed, or parameters added as an index:

$$\pi(a|s, \theta) \rightarrow \pi_{\theta}(a|s)$$

Summary: idea of Policy Gradient

1. stochastic policy

$$\pi(a|s, \theta)$$

Prob(action|state, parameters)

parameter



2. Change parameters so as to maximize rewards

3. Different from TD learning: No need for Q-values or V-values

Summary.

Artificial Neural Networks

Policy Gradient Methods

Wulfram Gerstner
EPFL, Lausanne, Switzerland

Part 3: Policy gradient with 1-step horizon

1. First steps toward deep reinforcement learning
2. Basic idea of policy gradient
3. **Example: 1-step horizon**

(previous slide)

To make these abstract notions concrete, we start with a simple example.

Policy Gradient methods: 1-step horizon

- Associate actions with stimuli
- Optimize directly the reward

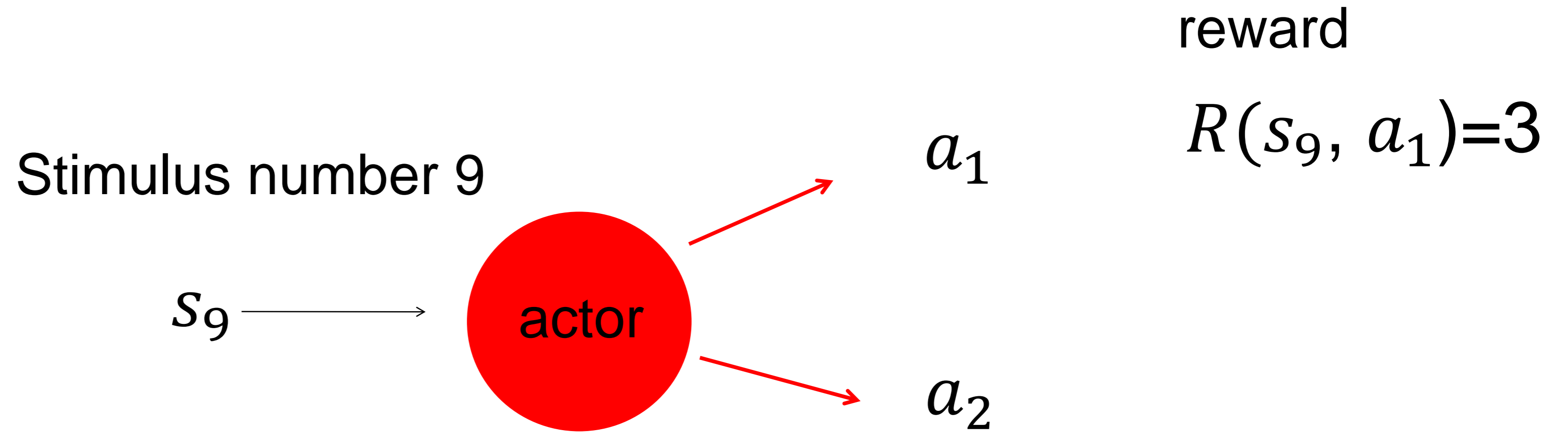

(previous slide)

As always in reinforcement learning, the goal is to optimize rewards. We start with a one-step horizon and a binary choice.

For each stimulus (here stimulus number 9) there is the choice of two actions.

For example if the agent takes action a_1 in response to stimulus s_9 , it receives a reward of value 3.

Policy Gradient methods: 1-step horizon

stimulus=state=input vector

Stimulus number 9 is a vector

$$\vec{x}^9 = (x_1^9, x_2^9, \dots, x_N^9)^T$$

$$s_9 = \vec{x}^9 \longrightarrow$$

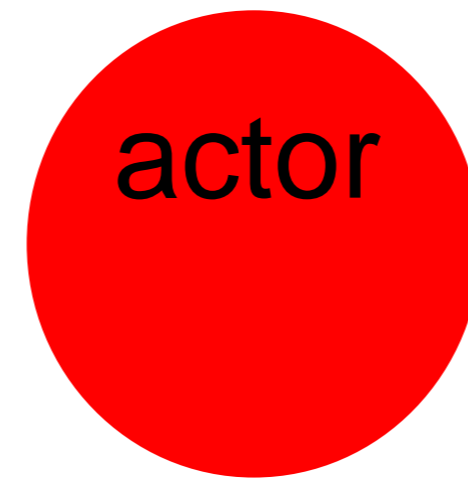

a_1

a_2

$$R(\vec{x}^9, a_1) = 3$$

(previous slide)

We model the stimulus s as in input vector (input pattern \vec{x}).

The actor can take two possible actions.

Policy Gradient methods: 1-step horizon

Aim: change weights of neuron

→ Maximize expected reward!

$$\langle R \rangle = \sum_x \sum_{y=\{0,1\}} \pi(y|\vec{x}) p(\vec{x}) R(y, \vec{x})$$

Stimulus number 9

$$\vec{x}^9 = (x_1^9, x_2^9, \dots, x_N^9)^T$$

Output of neuron

$$a_1 \rightarrow y = 1$$

$$s_9 = \vec{x}^9 \longrightarrow$$

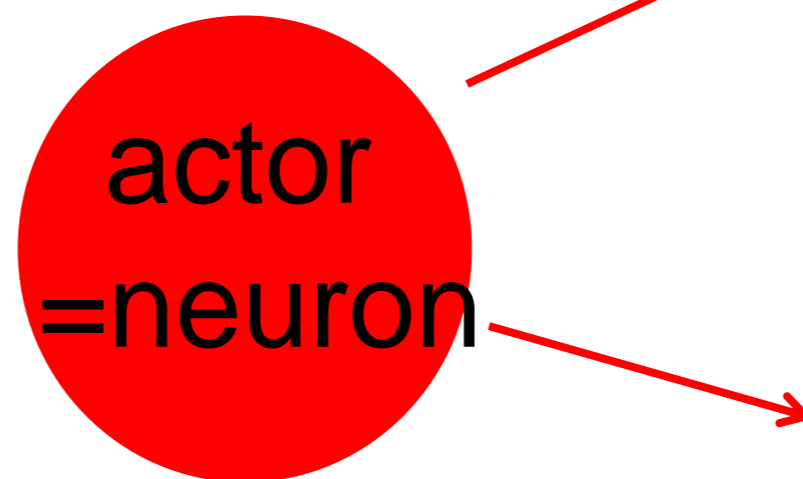

$$a_2 \rightarrow y = 0$$

Choice of actions

policy: $\pi(a_1|\vec{x}, \vec{w}) = \text{prob}(y = 1|\vec{x}, \vec{w}) = g\left(\sum_k^N w_k x_k\right)$

(previous slide)

We now model the policy as a single sigmoidal neuron with transfer function g and weight vector \vec{w} .

It is convenient to introduce a binary output variable: y takes the value of 1 if action a_1 is taken and zero otherwise.

The question now is:

How should we adapt the weight vector so that (averaged over all possible stimuli) the reward is maximal?

Define the mean reward as

$$\langle R \rangle = \sum_{\vec{x}} \sum_{y=\{0,1\}} \pi(y|\vec{x}) p(\vec{x}) R(y, \vec{x})$$

and use $\pi(y = 1|\vec{x}) = g(\sum_k^N w_k x_k)$

Exercise 1: maximize expected reward

*Exercise 1 now (10min)
Next Lecture at 11h47*

Exercise 1. (in Class): Single neuron as an actor

Assume an agent with binary actions $Y \in \{0, 1\}$. Action $y = 1$ is taken with a probability $\pi(Y = 1|\vec{x}; \vec{w}) = g(\vec{w} \cdot \vec{x})$, where \vec{w} are a set of weights and \vec{x} is the input signal that contains the state information. The function g is monotonically increasing and limited by the bounds $0 \leq g \leq 1$.

For each action, the agent receives a reward $R(Y, \vec{x})$.

a. Calculate the gradient of the mean reward $\langle R \rangle = \sum_{Y, \vec{x}} R(Y, \vec{x}) \pi(Y|\vec{x}; \vec{w}) P(\vec{x})$ with respect to the weight w_j .

Hint: Insert the policy $\pi(Y = 1|\vec{x}; \vec{w}) = g(\sum_k w_k x_k)$ and $\pi(Y = 0|\vec{x}; \vec{w}) = 1 - g(\sum_k w_k x_k)$. Then take the gradient.

b. The rule derived in (a) is a batch rule. Can you transform this into an ‘online rule’?

Hint: Pay attention to the following question: what is the condition that we can simply ‘drop the summation signs’?

$$\vec{x}^9 = (x_1^9, x_2^9, \dots, x_N^9)^T$$

\vec{x}^9

actor
=neuron

$$a_1 \rightarrow y = \frac{1}{N}$$

$$\pi(y = 1|\vec{x}, \vec{w}) = g\left(\sum_k w_k x_k\right)$$

$$a_2 \rightarrow y = 0$$

(your calculations)

Policy Gradient methods: 1-step horizon

blackboard1

$$\langle R \rangle = \sum_x \sum_{y=\{0,1\}} \pi(y|\vec{x}) p(\vec{x}) R(y, \vec{x})$$

reward

$$R(y, \vec{x})$$

policy

$$\pi(y = 1|\vec{x}, \vec{w}) = g(\vec{w}^\top \vec{x})$$

$$\pi(y = 0|\vec{x}, \vec{w}) = 1 - g(\vec{w}^\top \vec{x})$$

policy

$$\pi(y = 1|\vec{x}, \vec{w}) = g\left(\sum_k^N w_k x_k\right)$$

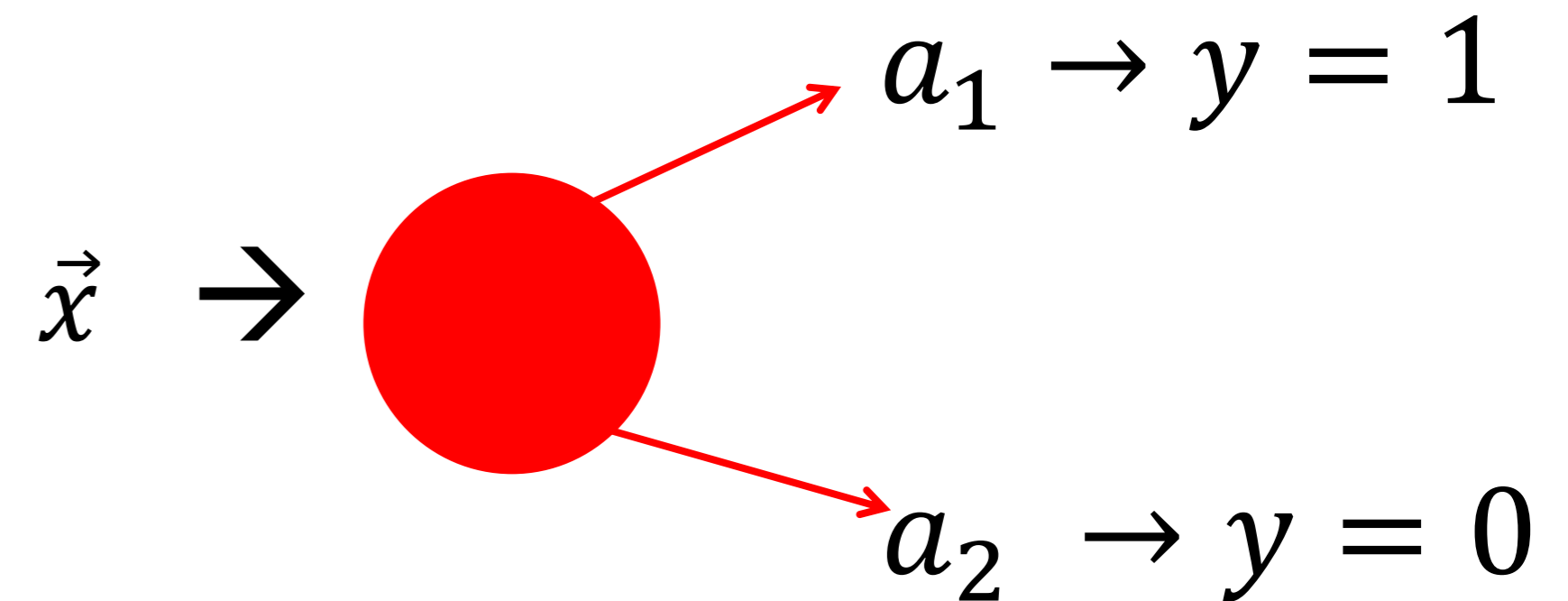

(your calculations)

From Batch rule to Online rule (pedestrian approach)

$$\langle R \rangle = \sum_x \sum_{y=\{0,1\}} \pi(y|\vec{x}) p(\vec{x}) R(y, \vec{x}) \quad (*)$$

blackboard1

policy

$$\pi(y = 1|\vec{x}, \vec{w}) = g(\vec{w}^\top \vec{x}) \quad (1)$$

$$\pi(y = 0|\vec{x}, \vec{w}) = 1 - g(\vec{w}^\top \vec{x}) \quad (2)$$

batch

$$\Delta w_j = \alpha$$

?

(3)

From Batch rule to Online rule

$$(*) \langle R \rangle = \sum_x \sum_{y=\{0,1\}} \pi(y|\vec{x}) p(\vec{x}) R(y, \vec{x})$$

$P(y, x)$

$\uparrow \uparrow$

batch

$$(3) \Delta w_j = \alpha \sum_x p(\vec{x}) [\text{?}] x_j$$

$$\Delta w_j = \alpha \sum_x p(\vec{x}) g' \left[\frac{\pi(y=1|\vec{x}, \vec{w})}{g(\vec{w}^T \vec{x})} R(1, x) - \frac{\pi(y=0|\vec{x}, \vec{w})}{1-g(\vec{w}^T \vec{x})} R(0, x) \right] \cdot x_j$$

$y=1$ $y=0$

$$= \alpha \cdot \sum_x p(\vec{x}) \sum_{y \in \{0,1\}} \pi(y|\vec{x}) \cdot R(y, x) \cdot g' \left[\frac{y}{g(\vec{w}^T \vec{x})} - \frac{1-y}{1-g(\vec{w}^T \vec{x})} \right] \cdot x_j \quad (4)$$

policy

$$\pi(y=1|\vec{x}, \vec{w}) = g(\vec{w}^T \vec{x}) \quad (1)$$

$$\pi(y=0|\vec{x}, \vec{w}) = 1 - g(\vec{w}^T \vec{x}) \quad (2)$$

Note: This is the pedestrian approach (see video for step-by step calculation) – there are more elegant ways of arriving at this result



Policy Gradient methods: 1-step horizon (summary)

Next Lecture at 12h15

reward

$$R(y, \vec{x})$$

policy

$$\pi(y = 1 | s, \vec{w}) = g\left(\sum_k^N w_k x_k\right)$$

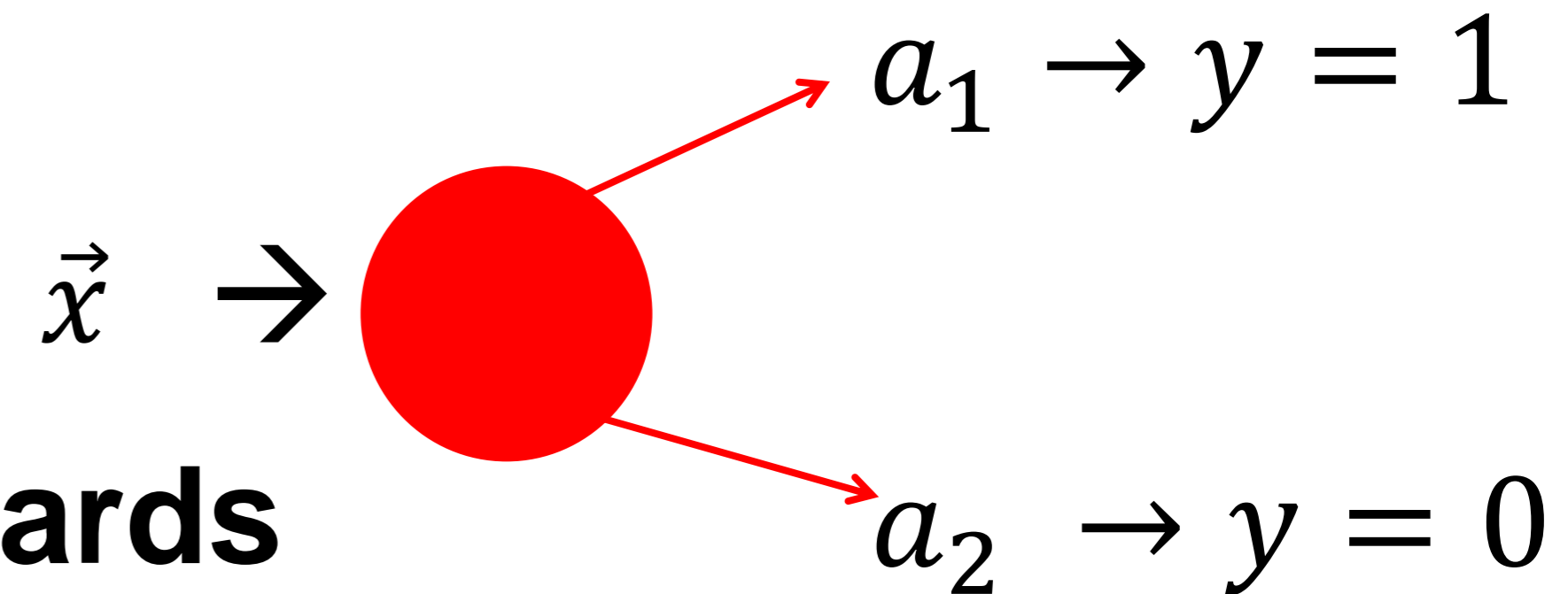

Update parameters to maximize rewards

$$\left. \begin{array}{l} \text{If } y = 1: \quad \Delta w_j = \alpha \frac{g'}{g} R(1, \vec{x}) x_j \\ \text{If } y = 0: \quad \Delta w_j = \alpha \frac{-g'}{(1-g)} R(0, \vec{x}) x_j \end{array} \right\} (4)$$

(previous slide)

The optimal update rule (last two lines) has a simple interpretation:

The weight w_j is moved in direction of x_j if the reward is positive.

The notation g' refers to the derivative of the sigmoidal function g .

Equation (4) can be written using the if condition (main slide), or alternatively

$$\Delta w_j = \alpha g' R(y, \vec{x}) \left[\frac{y}{g} - \frac{(1-y)}{(1-g)} \right] x_j \quad (4)$$

Here, the if condition is implemented by y and $(1-y)$, respectively.

Summary: Policy Gradient methods, from Batch-to-Online

Attention at transition 'Batch to Online':
→ natural statistical weight must be correct!

We have a **stochastic starting point** with weight $p(s)$
as well as **stochastic transitions** and a **stochastic policy**

$$\sum_{s'} P_{s \rightarrow s'}^a$$

weighting factor
for 'next state'

$$\sum_{a'} \pi(a' | s, \vec{w})$$

weighting factor
for 'next action'

(previous slide)

Batch rule (like in standard ANN): a single update is performed after having processed many patterns (minibatch) or all patterns (standard batch rule).

Online rule (like in standard ANN): an update is performed at every time step (after each pattern).

The example (and your calculations in the exercise) show that the transition from batch to online is not always possible by deleting the sum signs. In fact, it is only possible if the statistical weighting factor is correct.

Artificial Neural Networks

Policy Gradient Methods

Wulfram Gerstner

EPFL, Lausanne, Switzerland

Part 4: From Batch to Online: Log-likelihood trick

1. First steps toward deep reinforcement learning
2. Basic idea of policy gradient
3. Example: 1-step horizon
4. **From Batch to Online: Log-likelihood trick**

(previous slide)

Is there a more systematic way to perform the transition from batch to online?

The answer is yes and given by (what I call) the log-likelihood trick

From Batch to Online

Change parameters w to maximize average reward

$$\langle R \rangle_w = \sum_x \sum_y p(\vec{x}) \pi_w(y|\vec{x}) R(y, \vec{x})$$

Is there an 'elegant' way to keep a correct statistical weight when averaging a gradient in 'online' mode?

(previous slide)

The aim is to maximize the gradient of a reward function which involves averaging.

Is there a more systematic way to perform the transition from batch to online?
The answer is yes. How to implement this elegant derivation is explained next.

Log-likelihood trick

$$\langle R \rangle_w = \sum_x \sum_y p(\vec{x}) \pi_w(y|\vec{x}) R(y, \vec{x})$$

optimization yields online rule

$$\Delta w_j = \alpha R(y, \vec{x}) \frac{d}{dw_j} \ln \pi_w(y|\vec{x})$$

(your comments)

Log-likelihood trick

$$\begin{aligned}\nabla_{\theta} J &= \int \nabla_{\theta} p(H) R(H) dH \\ &= \int \frac{p(H)}{p(H)} \nabla_{\theta} p(H) R(H) dH \\ &= \int p(H) \nabla_{\theta} \log p(H) R(H) dH\end{aligned}$$

J = function you want to optimize

H = ensemble over which you integrate

(previous slide)

From BATCH to ONLINE (review of calculation with different notation).

Suppose you want to optimize some function J which is given by the integral over the **statistical ensemble H** . Instead of an integral you often have the discrete sum over all possible patterns, for example.

You want to do optimization by gradient ascent, therefore you need to calculate the gradient.

For the correct statistical weight you need the weight factor $p(H)$.

Normally this factor disappears when you naively take the gradient. However, if you rewrite this as the gradient of $(\log p)$ and then multiply by $p(H)$, you have the exactly the same result – but now the correct weight factor $p(H)$ is explicit. Once the weighting factor is visible, you can cut out the integral and $p(H)$ and get a valid online rule.

Policy gradient derivation

$$\nabla_{\theta} J = \int p(H) \nabla_{\theta} \log p(H) R(H) dH.$$

Taking the sample average as Monte Carlo (MC) approximation of this expectation by taking N trial histories we get

$$\nabla_{\theta} J = \mathbf{E}_H \left[\nabla_{\theta} \log p(H) R(H) \right] \approx \frac{1}{N} \sum_{n=1}^N \nabla_{\theta} \log p(H^n) R(H^n).$$

which is a fast approximation of the policy gradient for the current policy

(previous slide)

Delete the integral and $p(H)$ and sum over all examples, and you have a good approximation to your original integral. It works because the examples appear with their natural statistical weight!

Summary: Log-likelihood trick (1-step horizon)

Aim: change weights so as to maximize

$$\langle R_w \rangle = \sum_x \sum_y p(\vec{x}) \pi_w(y|\vec{x}) R(y, \vec{x})$$

Optimization by gradient decent yields online rule

$$\Delta w_j = \alpha R(y, \vec{x}) \frac{d}{dw_j} \ln \pi_w(y|\vec{x}) \quad (5) \quad (\text{online policy gradient})$$

The derivative of log of policy plays an important role!

(previous slide)

In the setting of a 1-step-horizon, a policy gradient algo adapts the parameters w so as to maximize the expected reward

$$\langle R_w \rangle = \sum_x \sum_y p(\vec{x}) \pi_w(y|\vec{x}) R(y, \vec{x})$$

Our aim is to arrive at an online update rule with the correct statistical weight. To achieve this we use the derivative of the logarithm of the policy. Then the we can cut out the natural statistical weight and find the online rule

$$\Delta w_j = \alpha R(y, \vec{x}) \frac{d}{dw_j} \ln \pi_w(y|\vec{x})$$

Note that w_j is one of the many parameters that together form the parameter vector w

Artificial Neural Networks

Policy Gradient Methods

Wulfram Gerstner

EPFL, Lausanne, Switzerland

Part 4*: From Batch to Online: Log-likelihood trick

1. First steps toward deep reinforcement learning
2. Basic idea of policy gradient
3. Example: 1-step horizon
4. From Batch to Online: Log-likelihood trick
- 4* Example (1-step horizon) revisited**

(previous slide).

We now return to our one-dimensional example!

Policy gradient evaluation: Example (1-step horizon)

Claim: log-likelihood trick yields
online rule

$$\Delta w_j = \alpha g' R(y, \vec{x}) \left[\frac{y}{g} - \frac{(1-y)}{(1-g)} \right] x_j \quad (4)$$

$$= \alpha \frac{g'}{g(1-g)} R(y, \vec{x}) [y - \langle y \rangle] x_j \quad (6)$$

Proof: use Eq. (5)

$$\Delta w_j = \alpha R(y, \vec{x}) \frac{d}{dw_j} \ln \pi_w(y|\vec{x})$$

(online policy gradient)

reward

$$R(y, \vec{x})$$

Blackboard 2b

policy

$$\pi(y = 1|\vec{x}, \vec{w}) = g(\vec{w}^\top \vec{x})$$

$$\pi(y = 0|\vec{x}, \vec{w}) = 1 - g(\vec{w}^\top \vec{x})$$

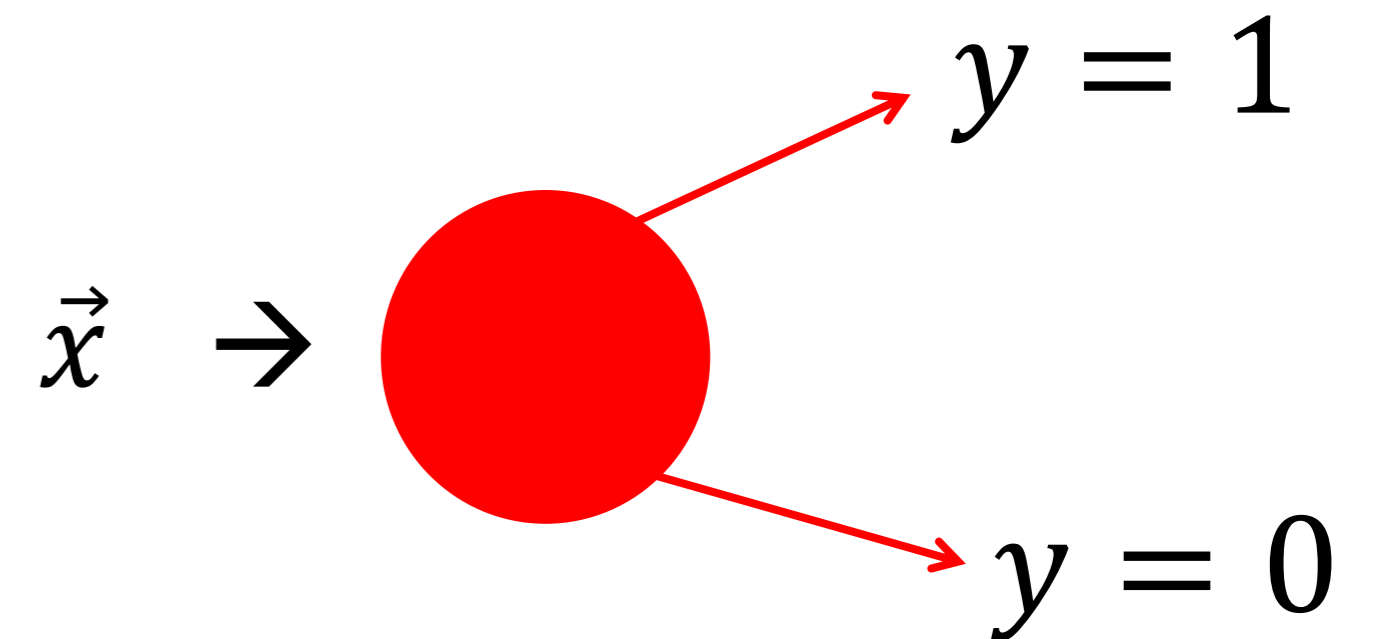

(your comments)

Update rule of example

observe input \vec{x} , output y , and reward $R(y, \vec{x})$

Earlier result, Eq. (4):

$$\text{If } y = 1: \quad \Delta w_j = \alpha \frac{g'}{g} \cdot R(1, \vec{x}) x_j$$

$$\text{If } y = 0: \quad \Delta w_j = \alpha \frac{-g'}{(1-g)} R(0, \vec{x}) x_j$$

policy

$$\pi(y = 1 | s, \vec{w}) = g \left(\sum_k^N w_k x_k \right)$$

Now rewritten as:

$$\Delta w_j = \alpha \frac{g'}{g(1-g)} R(y, \vec{x}) [y - \langle y \rangle] x_j \quad (6)$$

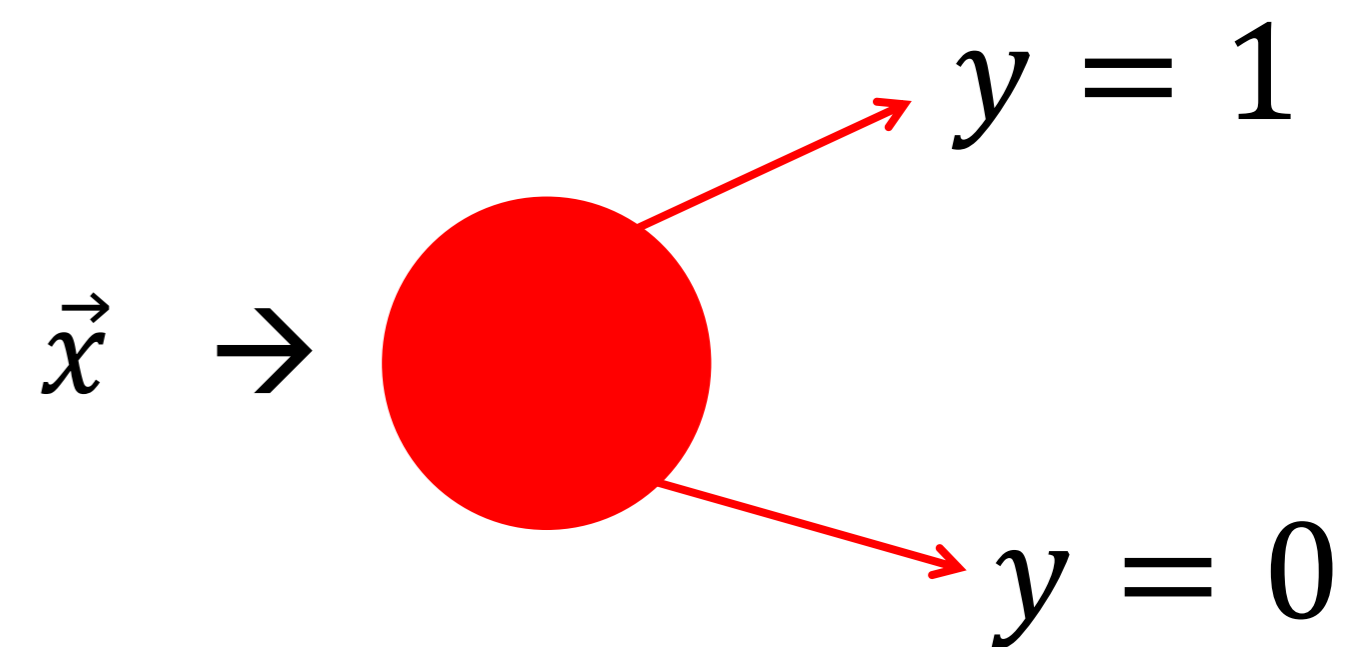

Note: $\langle y \rangle = g(\sum_k^N w_k x_k)$

(previous slide)

Using the log-likelihood trick we arrive at the same result as before but faster and, importantly, via a systematic sequence of steps.

Last line – two important comments:

- (i) The two cases ($y=+1$) and ($y=0$) can be summarized in a single update rule
- (ii) $\langle y \rangle$ is the expectation of the output, given the input vector \vec{x}

Comparison with Perceptron

parameter = weight w_j

$$\Delta w_j \propto R(y, \vec{x}) [y - \langle y \rangle] x_j$$

Weight vector turns in direction of input

$$\Delta \mathbf{w} \propto \pm \mathbf{x}$$

$$R > 0 \text{ and } y = 1 \rightarrow \Delta \mathbf{w} \propto +\mathbf{x}$$

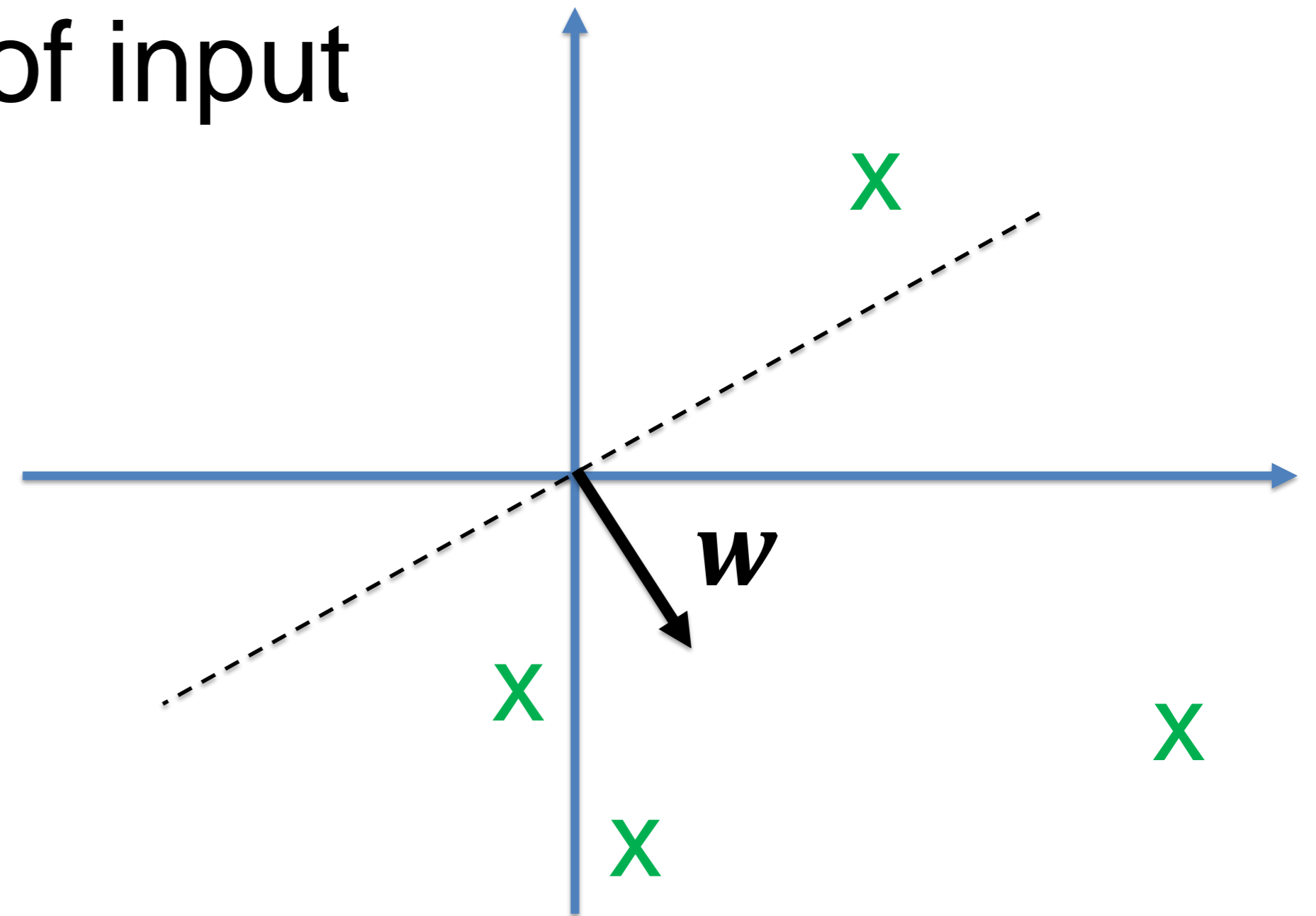

(previous slide)

Similar to the perceptron update rule, the update with gradient descent can be interpreted as a weight vector that turns in direction of an input pattern (with positive or negative sign)

Comparison with Biology

parameter = weight w_j

$$\Delta w_j \propto R(y, \vec{x}) [y - \langle y \rangle] x_j$$

Stimulus

reward

pre

j

i

post

Weight vector turns in direction of input

Three factors: reward

post

pre

$$\Delta w_{ij} = \eta \frac{g'}{g(1-g)} R(\vec{y}, \vec{x}) [y_i - \langle y_i \rangle] x_j$$

postsynaptic factor is

'activity – expected activity'

(previous slide)

The update rule give also rise to an interesting biological interpretation.

The learning rule depends on three factors:

- (i) The reward
- (ii) The 'state' of the postsynaptic neuron where 'state'=activity minus expected activity
- (iii) The presynaptic activity

Presynaptic cell: the neuron that sends a signal across the connection (sender)

Postsynaptic cell: the neuron that receives the signal (receiver).

We will come back to the link between reinforcement learning and the brain in lecture 12.

Generalization: subtract a reward baseline

maximizing $\langle R \rangle = \sum_x \sum_y p(\vec{x}) \pi(y|\vec{x}) R(y, \vec{x})$

we derived this online gradient rule

$$\Delta w_j \propto R(y, \vec{x}) [y - \langle y \rangle] x_j$$

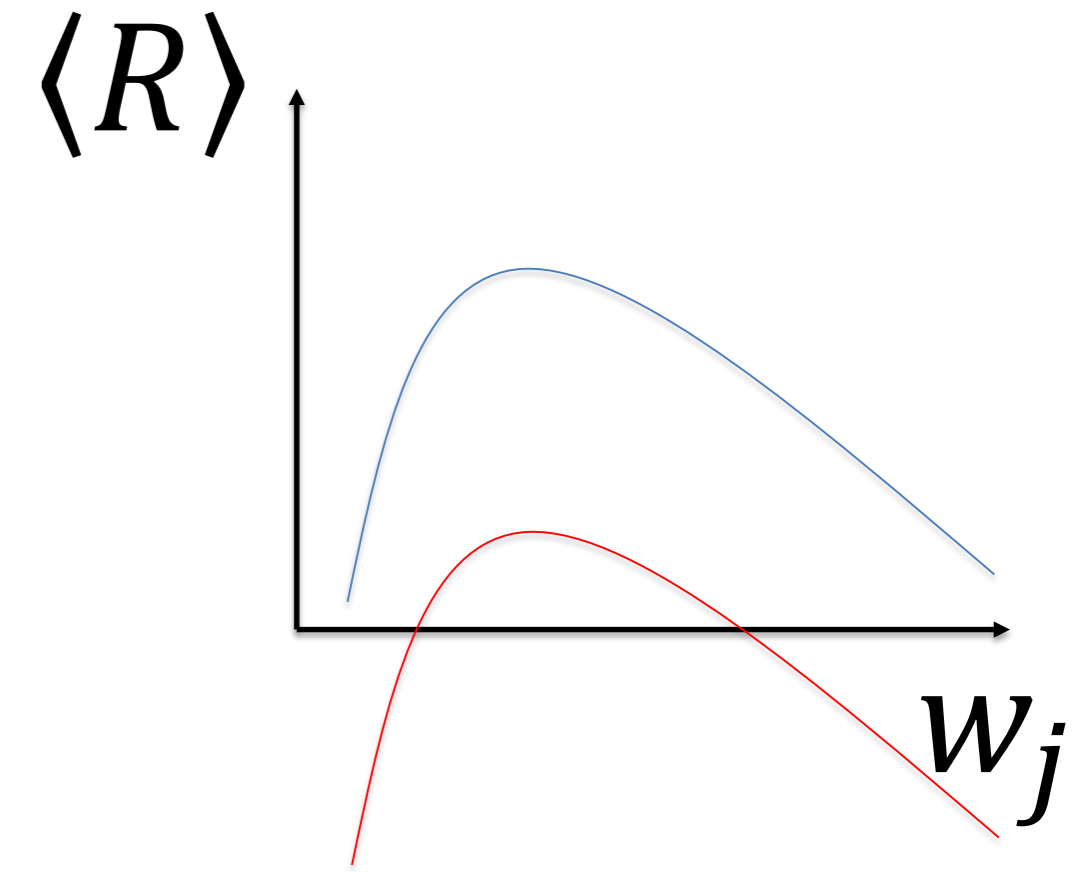

But then this rule is also an online gradient rule

$$\Delta w_j \propto [R(y, \vec{x}) - b] [y - \langle y \rangle] x_j$$

with the same location of maximum

(start with $\langle R - b \rangle$, but the baseline shift
is irrelevant if we take the gradient)

(previous slide)

Note that we are interested in finding the set of weights that optimize the expected reward $\langle R \rangle$.

The update rule has been derived by taking the gradient on the mean reward $\langle R \rangle$.

But a function $\langle R - b \rangle$ with constant bias b would have exactly the same location of the maximum.

If we repeated the gradient steps, the results would lead to an update rule with a factor $[R - b]$ instead of R . Therefore, the rule with $[R - b]$ is also a valid online rule.

Why subtract a baseline?

Subtracting an appropriate baseline makes an online algorithm less noisy so that it converges better. Good baseline is mean.

Example: estimate mean of product $x(y - \bar{y})$ of two indep. variables

with subtraction

mean:

$$\langle (x - \bar{x})(y - \bar{y}) \rangle = 0$$

Sample k:

$$(x_k - \bar{x})(y_k - \bar{y})$$

$$x_k = 5 \pm 1$$

$$y_k = 8 \pm 1$$

without subtraction

mean:

$$\langle x(y - \bar{y}) \rangle = 0$$

Sample k:

$$x_k(y_k - \bar{y})$$

$$= (x_k - \bar{x})(y_k - \bar{y}) + \bar{x}(y_k - \bar{y})$$

$$\text{order} = \pm 1$$

$$\text{noise} = \pm 5$$

(previous slide)

Why is it useful to subtract the mean?

Whatever the choice of baseline, the algorithm should eventually converge to the same set of parameters. However, since the algorithm is based on stochastic gradient descent (i.e., the online rule instead of the full batch rule), the algorithm makes **noisy steps** that only go on average in the right direction.

Subtracting a baseline that is close to the mean generally reduces the noise.

The example with a product of independent variables shows that by subtracting the mean of x , the noise is considerably reduced in each of the samples!

Note that we have seen earlier that the update rule of policy gradient can be written as a product of R and something like $(y - \bar{y})$ for fixed input. Replace x by R and you are done, assuming independence of the two variables.

Quiz: Policy Gradient and Reinforcement learning

Your friend has followed over the weekend a tutorial in reinforcement learning and claims the following. Is he right?

- All reinforcement learning algorithms work either with Q-values or V-values
- The transition from batch to online is always easy: you just drop the summation signs and bingo!
- Both TD algorithms and policy gradient algorithms aim to optimize the expected total reward (potentially discounted if there are multiple time steps)
- The derivative of the log-policy is some abstract quantity that has no intuitive meaning.

(your comments)

Exercise 2: Subtract baseline

Exercise 2 now
Next Lecture at 14h15

Exercise 2. Subtracting the mean

You have two stochastic variables, x and y with means $\langle x \rangle$ and $\langle y \rangle$. Angles denote expectations. We are interested in the product $z = (x - b)(y - \langle y \rangle)$ with a fixed parameter b .

- Show that $\langle z \rangle$ is independent of the choice of the parameter b .
- Show that $\langle z^2 \rangle$ is minimal if $b = \frac{\langle xf(y) \rangle}{\langle f(y) \rangle}$, where $f(y) = (y - \langle y \rangle)^2$.
Hint: write $\langle z^2 \rangle = F(b)$ and set $dF/db = 0$.
- What is the optimal b , if x and $f(y)$ are approximately independent?
- Make the connection to policy gradient rules.

Hint: take $x = r$ (reward) and y the action taken in state s . Compare with the policy gradient formula of the simple 1-neuron actor. What can you conclude for the best value of b ? Consider different states s . Why should b depend on s ?

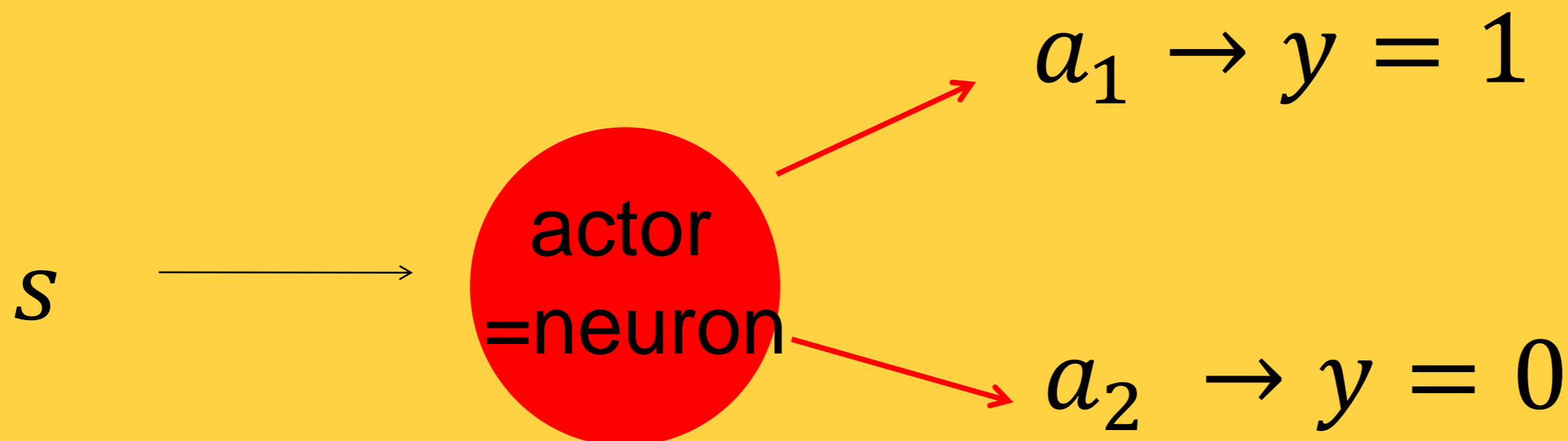

(your calculations)

Artificial Neural Networks

Policy Gradient Methods

Wulfram Gerstner
EPFL, Lausanne, Switzerland

Part 5: Multiple time steps

1. First steps toward deep reinforcement learning
2. Basic idea of policy gradient
3. Example: 1-step horizon
4. Log-likelihood trick
5. **Multiple time steps**

(previous slide)

So far the discussion has been restricted to scenarios with a one-step horizon.

The agent takes an action, gets a reward, and the episode ends.

Now we need to generalize to scenarios that extend over multiple time steps.

Teaching monitoring – monitoring of understanding

[] today, up to here, at least 60% of material was new to me.

[] up to here, I have the feeling that I have been able to follow (at least) 80% of the lecture.

(previous slide)

Policy Gradient methods over multiple time steps

Aim:

update the parameters θ
of the policy $\pi(a|s, \theta)$

so as to maximize the average
total discounted reward from s
(expected **Return**)

$$\langle R_{s_t \rightarrow s_{end}} \rangle = \langle r_t + \gamma^1 r_{t+1} + \gamma^2 r_{t+2} + \gamma^3 r_{t+3} \quad \rangle$$

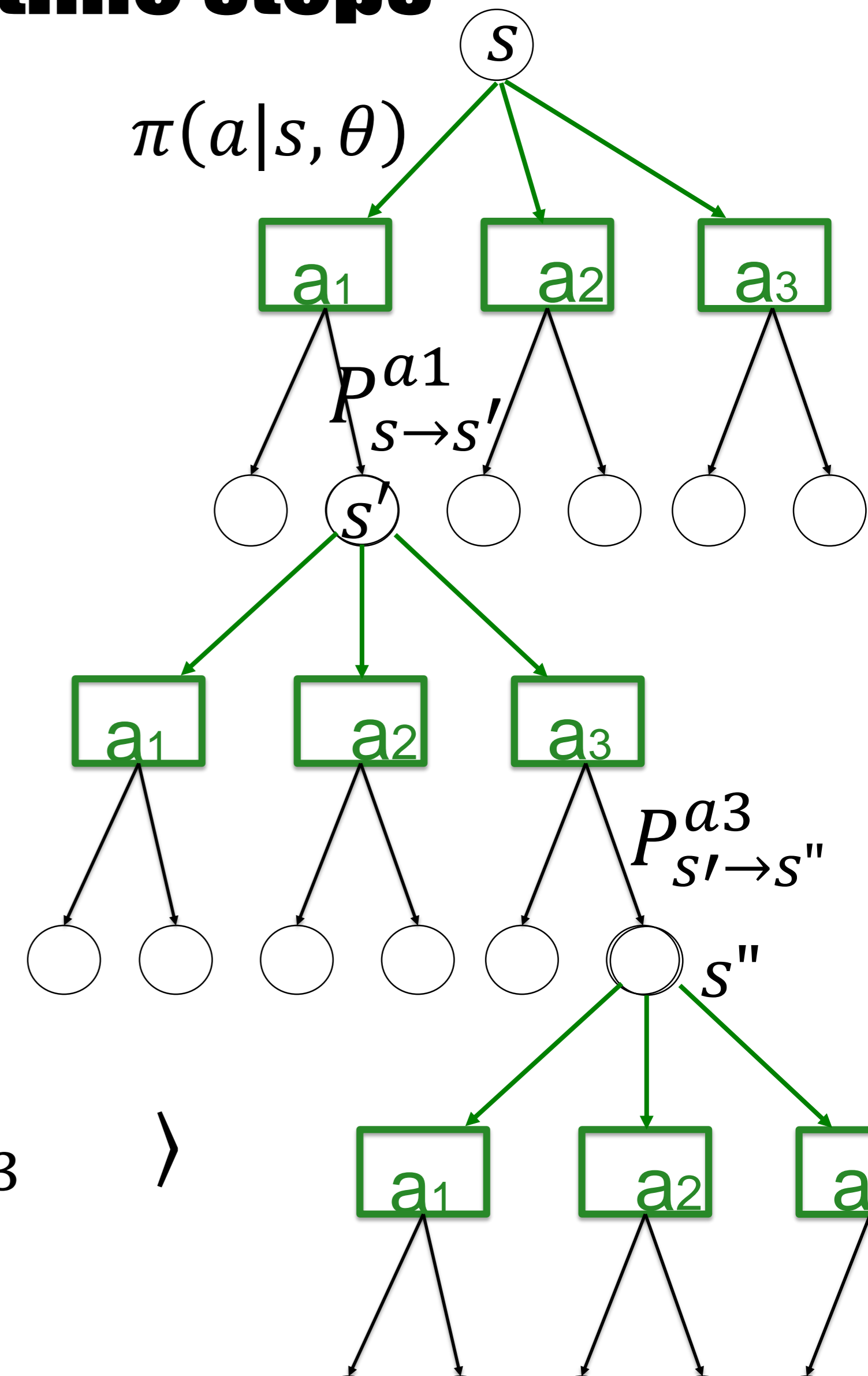

(previous slide)

We use the same graph of the multistep Markov decision model as for the derivation of the Bellman equation.

However, now we work directly on a policy $\pi(a|s,\theta)$ which depends on parameters θ .

Policy Gradient methods over multiple time steps

Blackboard 3

$$\langle R_{s_t \rightarrow s_{end}} \rangle = \langle r_t + \gamma^1 r_{t+1} + \gamma^2 r_{t+2} + \gamma^3 r_{t+3} \rangle$$

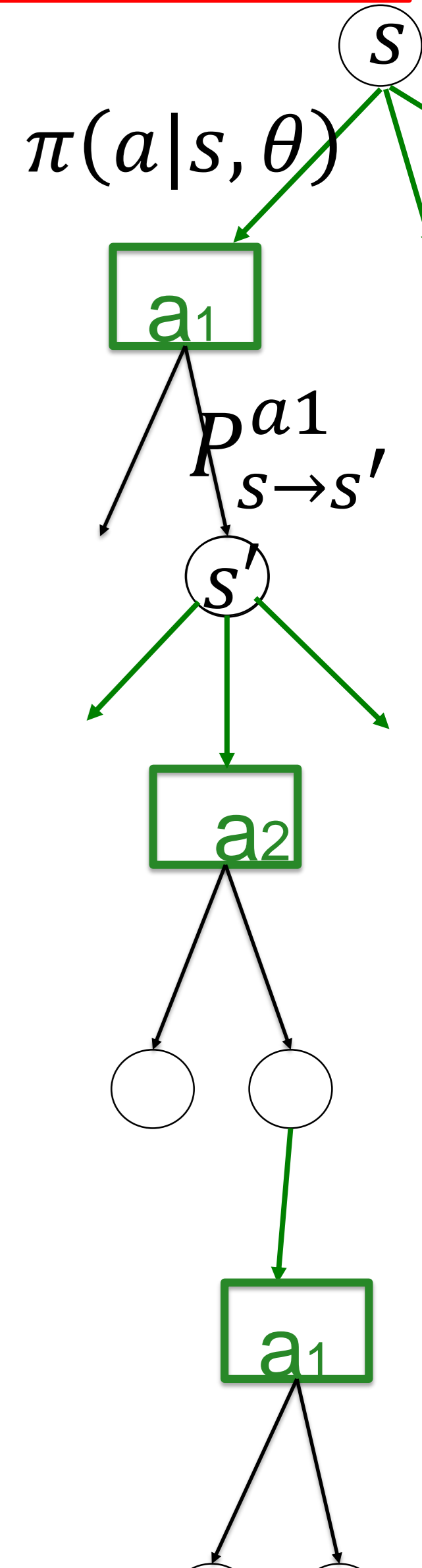

Policy Gradient methods over multiple time steps

Calculation yields several terms of the form

Total accumulated discounted reward
collected in one episode starting at s_t, a_t

$$\begin{aligned} \Delta\theta_j \propto & \left[R_{s_t \rightarrow s_{end}}^{a_t} \right] \frac{d}{d\theta_j} \ln[\pi(a_t | s_t, \theta)] \\ & + \gamma \left[R_{s_{t+1} \rightarrow s_{end}}^{a_{t+1}} \right] \frac{d}{d\theta_j} \ln[\pi(a_{t+1} | s_{t+1}, \theta)] \\ & + \dots \end{aligned}$$

(previous slide)

We consider a single episode that started in state s_t with action a_t and ends after several steps in the terminal state s_{end}

The result of the calculation gives an update rule for each of the parameters.

The update of the parameter θ_j contains several terms.

(i) the first term is proportional to the total accumulated (discounted) reward, also called return $R_{s_t \rightarrow s_{end}}^{a_t}$

(ii) the second term is proportional to γ times the total accumulated (discounted) reward but starting in state s_{t+1}

(iii) the third term is proportional to γ^2 times the total accumulated (discounted) reward but starting in state s_{t+2}

(iv) We can think of this update as one update step for one episode. Analogous to the terminology last week, Sutton and Barto call this the Monte-Carlo update for one episode.

Note that each of the terms is proportional to $\ln \pi$

Pseudo-code for algo REINFORCE (Policy Gradient)

REINFORCE: Monte-Carlo Policy-Gradient Control (episodic) for π_*

Input: a differentiable policy parameterization $\pi(a|s, \theta)$

Algorithm parameter: step size $\alpha > 0$

Initialize policy parameter $\theta \in \mathbb{R}^{d'}$ (e.g., to $\mathbf{0}$)

Loop forever (for each episode):

Generate an episode $S_0, A_0, r_1, \dots, S_{T-1}, A_{T-1}, r_T$, following $\pi(\cdot|\cdot, \theta)$

Loop for each step of the episode $t = 0, 1, \dots, T - 1$:

$$G \leftarrow \sum_{k=t+1}^T \gamma^{k-t-1} r_k \quad (G_t)$$
$$\theta \leftarrow \theta + \alpha \gamma^t G \nabla \ln \pi(A_t|S_t, \theta)$$

From book:

Sutton and Barto, 2018

Different states S_0, S_1, S_2, \dots during one episode

G = total accumulated reward during the episode starting at S_t ;

All updates done AT THE END of the episode

Algorithm maximizes expected discounted rewards starting at S_0

(previous slide)

The algorithm in Pseudocode taken from the book of Sutton and Barto. The update concerns a single episode.

The only notational difference with respect to the earlier slide is a rewrite of the factors gamma – you can check the equivalence by taking a piece of paper.

Note that for an implementation it would be most convenient to start at the terminal state of the episode and work backwards so as to reuse the return calculations.

Variations of this algorithm are the basis of policy gradient methods and widely used in applications.

IMPORTANT: This version of the algo is derived for the situation where we optimize the return from a known starting state and a known terminal state. In practice it works better to optimize the return from ALL possible states (appropriately weighted).

Summary: Policy Gradient methods over multiple time steps:

-starting at s_t

-derivative of log-policy at different states visited during episode,

$$\frac{d}{d\theta_j} \ln[\pi(a_t | s_t, \theta)] \quad R_{s_t \rightarrow s_{end}}^{a_t}$$

$$+\gamma^1 \frac{d}{d\theta_j} \ln[\pi(a_{t+1} | s_{t+1}, \theta)] \quad R_{s_{t+1} \rightarrow s_{end}}^{a_{t+1}}$$

$$+\gamma^2 \frac{d}{d\theta_j} \ln[\pi(a_{t+2} | s_{t+2}, \theta)] \quad R_{s_{t+2} \rightarrow s_{end}}^{a_{t+2}}$$

- Multiplied with the returns from each state

- discounted with γ

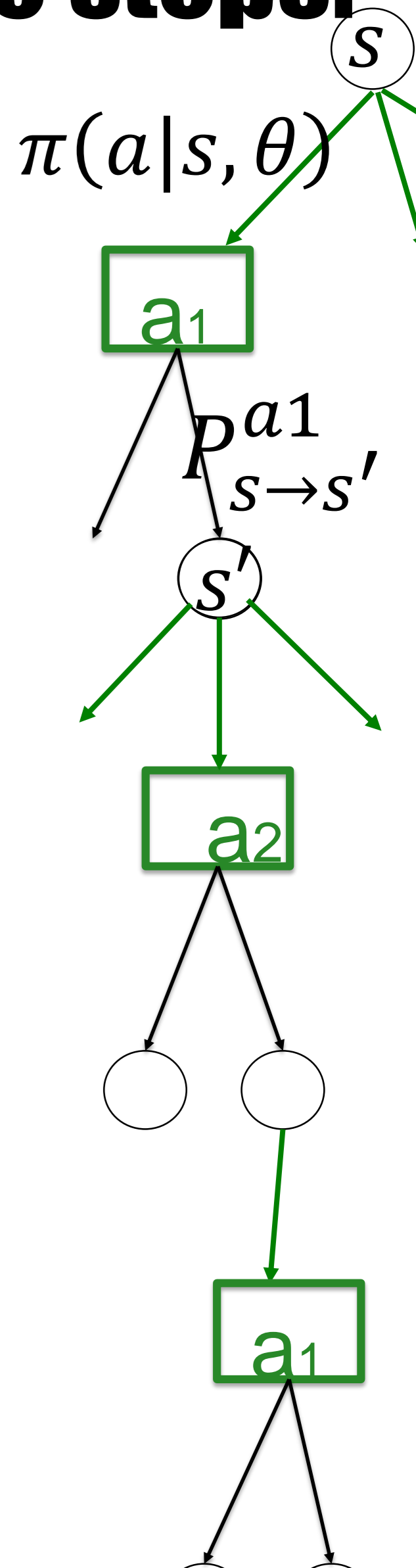

(previous slide)

Summary of the basic algorithmic principle of a policy gradient method over multiple time steps, if many episodes start in the same state s , and you optimize return for this state s . Episodes end at the terminal state. This is called the episodic case.

In practice algorithms that optimize the return from all states work better, because this version of the episodic algorithm puts most weight on rewards in states close to the starting state. However, if the only reward is at the end (at the terminal state) then it is better to either use a discount very close to 1, or to optimize the return from ALL states (i.e., also from those closer to the target).

We will come back to this in the lecture on deep reinforcement learning

Here we optimize $\langle R_{s_t \rightarrow s_{end}} \rangle$ where the return is averaged over paths starting in s_t

Later we optimize $\langle R_{s \rightarrow s_{end}} \rangle$ where the return is averaged over all states encountered during the path. Thus we optimize the MEAN return. This usually works better.

Part 6: Subtracting the mean via the value function

1. First steps toward deep reinforcement learning
2. Basic idea of policy gradient
3. Example: 1-step horizon
4. Log-likelihood trick
5. Multiple time steps
6. **Subtracting the mean via the value function**

(previous slide)

In the simple one-step scenario we have seen that we can subtract a bias b from the reward.

Review: subtract a reward baseline (1-step horizon)

we derived this online gradient rule (for 1-step horizon)

$$\Delta w_j \propto R(y, \vec{x}) [y - \langle y \rangle] x_j$$

But then this rule is also an online gradient rule

$$\Delta w_j \propto [R(y, \vec{x}) - b] [y - \langle y \rangle] x_j$$

with the same expectation

(because a baseline shift drops out if we take the gradient)

(previous slide)

The question arises whether the same is true in the multi-step episodes.

The answer is YES.

Subtract a reward baseline

online gradient rule for multi-step horizon
has many terms of form

$$\Delta\theta_j \propto [R_{s_t \rightarrow s_{end}}^{a_t}] \frac{d}{d\theta_j} \ln[\pi(a_t | s_t, \theta)]$$

But then this rule is also an online gradient rule

$$\Delta\theta_j \propto [R_{s_t \rightarrow s_{end}}^{a_t} - b(s_t)] \frac{d}{d\theta_j} \ln[\pi(a_t | s_t, \theta)]$$

with the same optimum

(because a baseline shift drops out if we take the gradient)

(previous slide)

Please remember that the full update rule for the parameter θ_j

in a multi-step episode contains several terms of this form; here only the first of these terms is shown.

Similar to the case of the one-step horizon, we can subtract a bias b from the reward without changing the location of the maximum of the total expected return.

Moreover, this bias $b(s_t)$ can itself depend on the state s_t .

Thus the update rule now has terms

$$\begin{aligned} \Delta\theta_j \propto & [R_{s_t \rightarrow s_{end}}^{a_t} - b(s_t)] \frac{d}{d\theta_j} \ln[\pi(a_t | s_t, \theta)] \\ & + \gamma [R_{s_{t+1} \rightarrow s_{end}}^{a_{t+1}} - b(s_{t+1})] \frac{d}{d\theta_j} \ln[\pi(a_{t+1} | s_{t+1}, \theta)] \\ & + \gamma^2 [R_{s_{t+2} \rightarrow s_{end}}^{a_{t+2}} - b(s_{t+2})] \frac{d}{d\theta_j} \ln[\pi(a_{t+2} | s_{t+2}, \theta)] \\ & + \dots \end{aligned}$$

Subtract a reward baseline

Total accumulated discounted reward
collected in one episode starting at s_t, a_t

$$\Delta\theta_j \propto [R_{s_t \rightarrow s_{end}}^{a_t} - b(s_t)] \frac{d}{d\theta_j} \ln[\pi(a_t | s_t, \theta)] + \dots$$

- 
- The bias b can depend on state s
 - Good choice is $b = \text{'mean of } [R_{s_t \rightarrow s_{end}}^{a_t}] \text{'}$
 - take $b(s_t) = V(s_t)$
 - learn value function $V(s)$

(previous slide

Is there a choice of the bias $b(s_t)$ that is particularly good?

One attractive choice is to take the bias equal to the expectation (or empirical mean). The logic is that if you take an action that gives more accumulated discounted reward than your empirical mean in the past, then this action was good and should be reinforced.

If you take an action that gives less accumulated discounted reward than your empirical mean in the past, then this action was not good and should be weakened.

But what is the expected discounted accumulated reward? This is, by definition, exactly the value of the state. Hence a good choice is to subtract the V-value.

And here is where finally the idea of Bellman equation and TD learning comes in through the backdoor: we can learn the V-value, and then use it as a bias in policy gradient.

Deep Reinforcement Learning: Lunar Lander and other games

actions

advance *push left*

value

$V(s)$

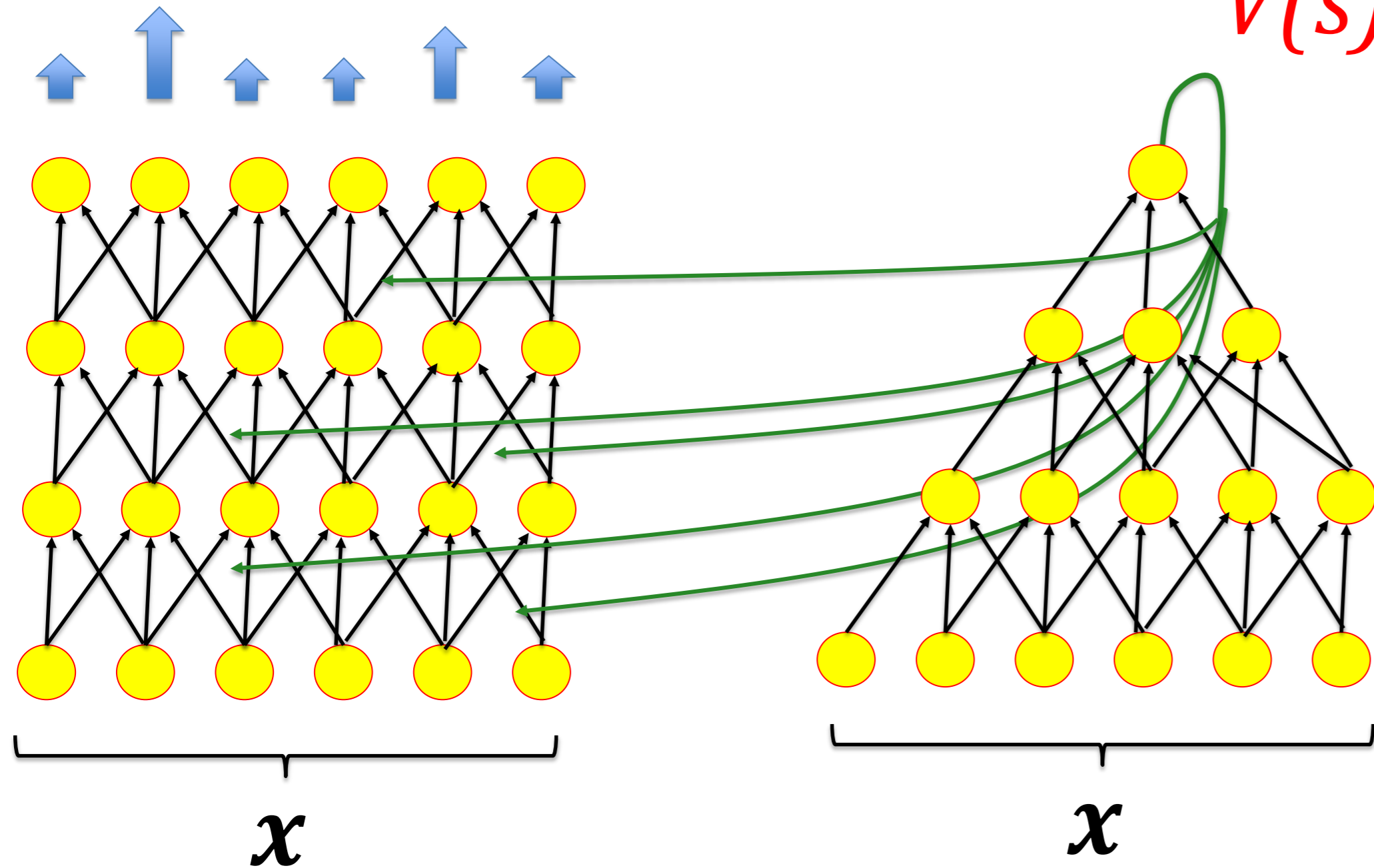

Aim: land between poles

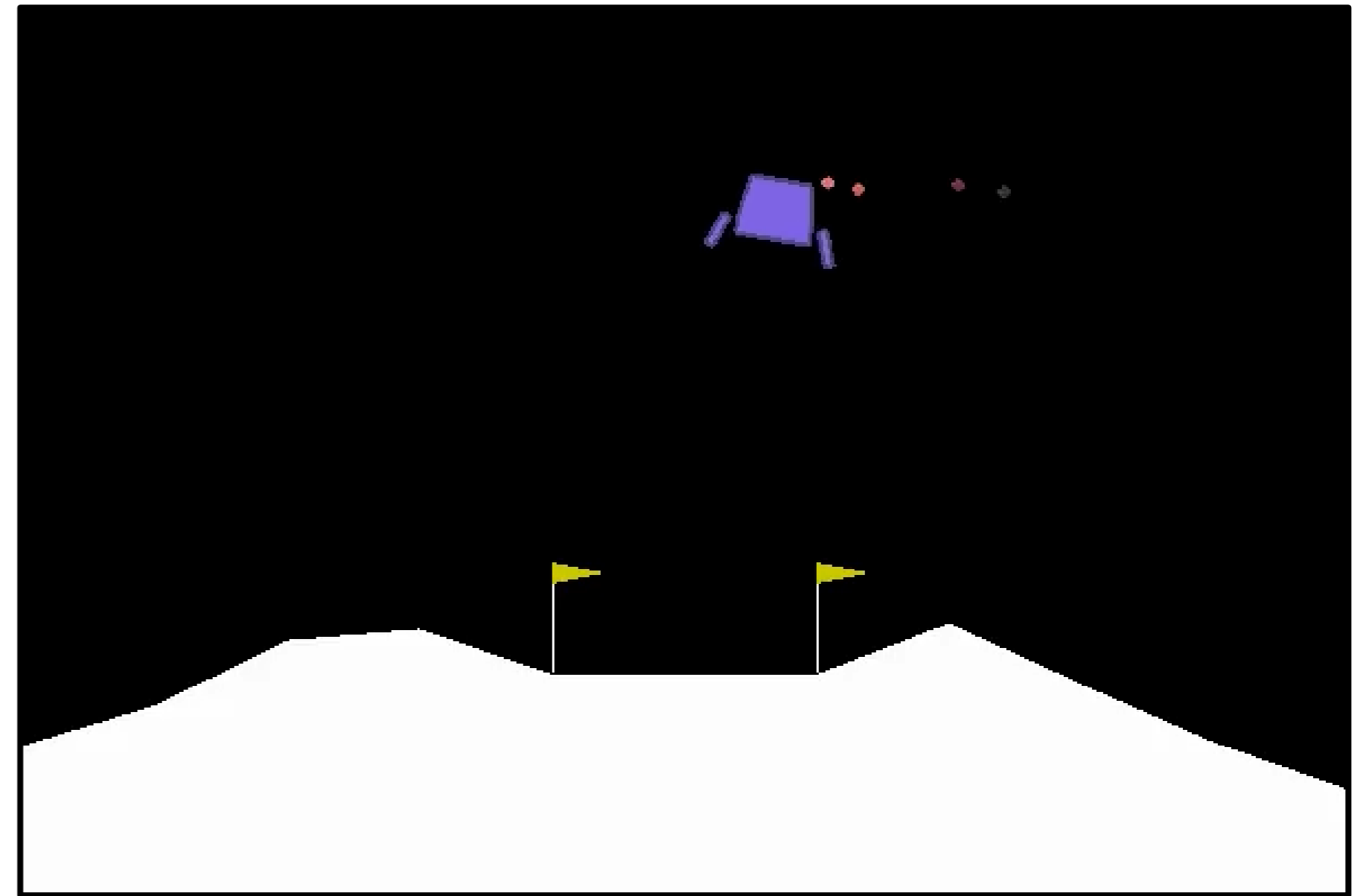

(previous slide)

And the value v can for example be estimated (=learned) in a separate network.

Learning two Neural Networks: actor and value

Actions:

- Learned by Policy gradient
- Uses $V(x)$ as baseline

Value function:

- Estimated by Monte-Carlo
- provides baseline $b=V(x)$ for action learning

Parameters are the network weights θ

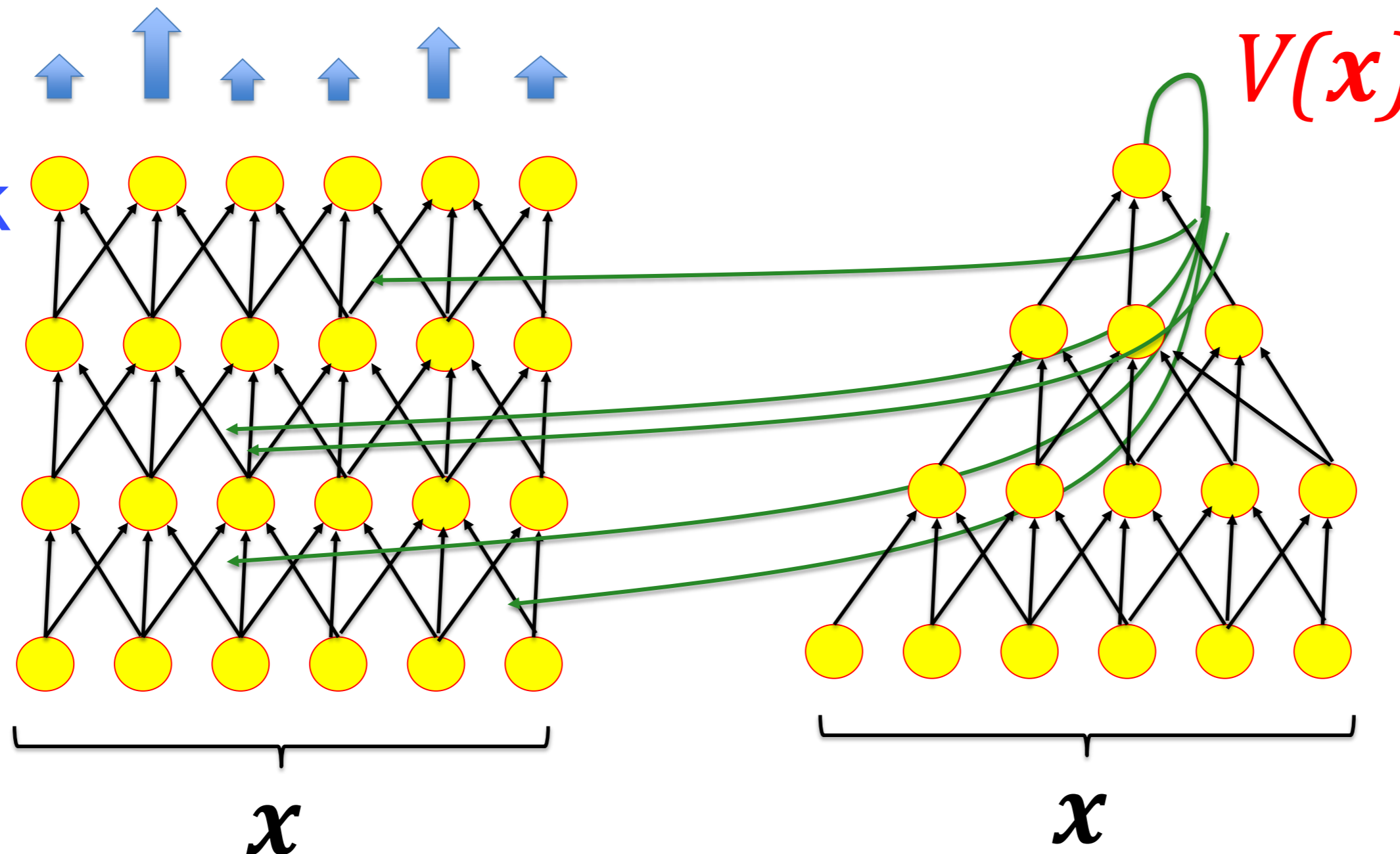

Parameters are the weights w

x = states from episode:
 $S_t, S_{t+1}, S_{t+2},$

(previous slide)

In the latter case we have two networks:

The actor network learns a first set of parameters, called θ in the algorithm of Sutton and Barto.

The value network learns a second set of parameters, with the label w .

The value $b(x = s_{t+n}) = V(x)$ is the estimated total accumulated discounted reward of an episode starting at $x = s_{t+n}$

The total accumulated discounted ACTUAL reward in ONE episode is $R_{s_{t+n} \rightarrow s_{end}}^{a_{t+n}}$

'REINFORCE' with baseline

From book:
Sutton and Barto, 2018

REINFORCE with Baseline (episodic), for estimating $\pi_{\theta} \approx \pi_*$

Input: a differentiable policy parameterization $\pi(a|s, \theta)$

Input: a differentiable state-value function parameterization $\hat{v}(s, \mathbf{w})$

Algorithm parameters: step sizes $\alpha^{\theta} > 0, \alpha^{\mathbf{w}} > 0$

Initialize policy parameter $\theta \in \mathbb{R}^{d'}$ and state-value weights $\mathbf{w} \in \mathbb{R}^d$ (e.g., to $\mathbf{0}$)

Loop forever (for each episode).

Generate an episode $S_0, A_0, \mathbf{r}_1, \dots, S_{T-1}, A_{T-1}, \mathbf{r}_T$ following $\pi(\cdot|\cdot, \theta)$

Loop for each step of the episode $t = 0, 1, \dots, T - 1$:

$$G \leftarrow \sum_{k=t+1}^T \gamma^{k-t-1} r_k \quad (G_t)$$

$$\delta \leftarrow G - \hat{v}(S_t, \mathbf{w})$$

$$\mathbf{w} \leftarrow \mathbf{w} + \alpha^{\mathbf{w}} \gamma^t \delta \nabla \hat{v}(S_t, \mathbf{w})$$

$$\theta \leftarrow \theta + \alpha^{\theta} \gamma^t \delta \nabla \ln \pi(A_t | S_t, \theta)$$

(previous slide)

Algorithm in pseudocode taken from the book of Sutton and Barto.

For the actor, the algorithm evaluates terms of the form

$$\left[R_{s_{t+n} \rightarrow s_{end}}^{a_{t+n}} - b(s_{t+n}) \right] \frac{d}{d\theta_j} \ln[\pi(a_{t+n} | s_{t+n}, \theta)]$$

Where the return is $G = R_{s_{t+n} \rightarrow s_{end}}^{a_{t+n}}$

And the bias estimate is $v(s_{t+n}) = b(s_{t+n})$

The terminal state in their notation occurs at time T and the initial state has index 0.

For the value function, they use Monte-Carlo estimation of the total accumulated reward in one episode (see last week).

Why subtract the mean?

Subtracting the expectation provides estimates that have (normally) smaller variance (look less noisy)

Note: in multi-step RL, the minimal variance is not exactly at bias=expectation.

Reason: correlations

(previous slide)

Why is it useful to subtract the mean?

Whatever the choice of baseline, the algorithm should eventually converge to the same set of parameters. However, since the algorithm is based on stochastic gradient descent (i.e., the online rule instead of the full batch rule), the algorithm makes **noisy steps** that only go on average in the right direction.

Subtracting a baseline that is close to the mean generally reduces the noise.

The example with a product of independent variables shows that by subtracting the mean of x , the noise is considerably reduced in each of the samples! (Exercise 2)

Unfortunately, in a multi-step reinforcement learning scenario, the minimal noise is not exactly the situation where one subtracts the mean because of correlations, but it is close to it.

Outlook: Deep Reinforcement Learning

Policy gradient involves many terms of the form:

$$\frac{d}{d\theta_j} \ln[\pi(a_t | s_t, \theta)]$$

Output of network: policy

Parameters are the weights of the network.

$$[R_{s_t \rightarrow s_{end}}^{a_t} - (V(s_t))]$$

Output of network:
value (baseline)

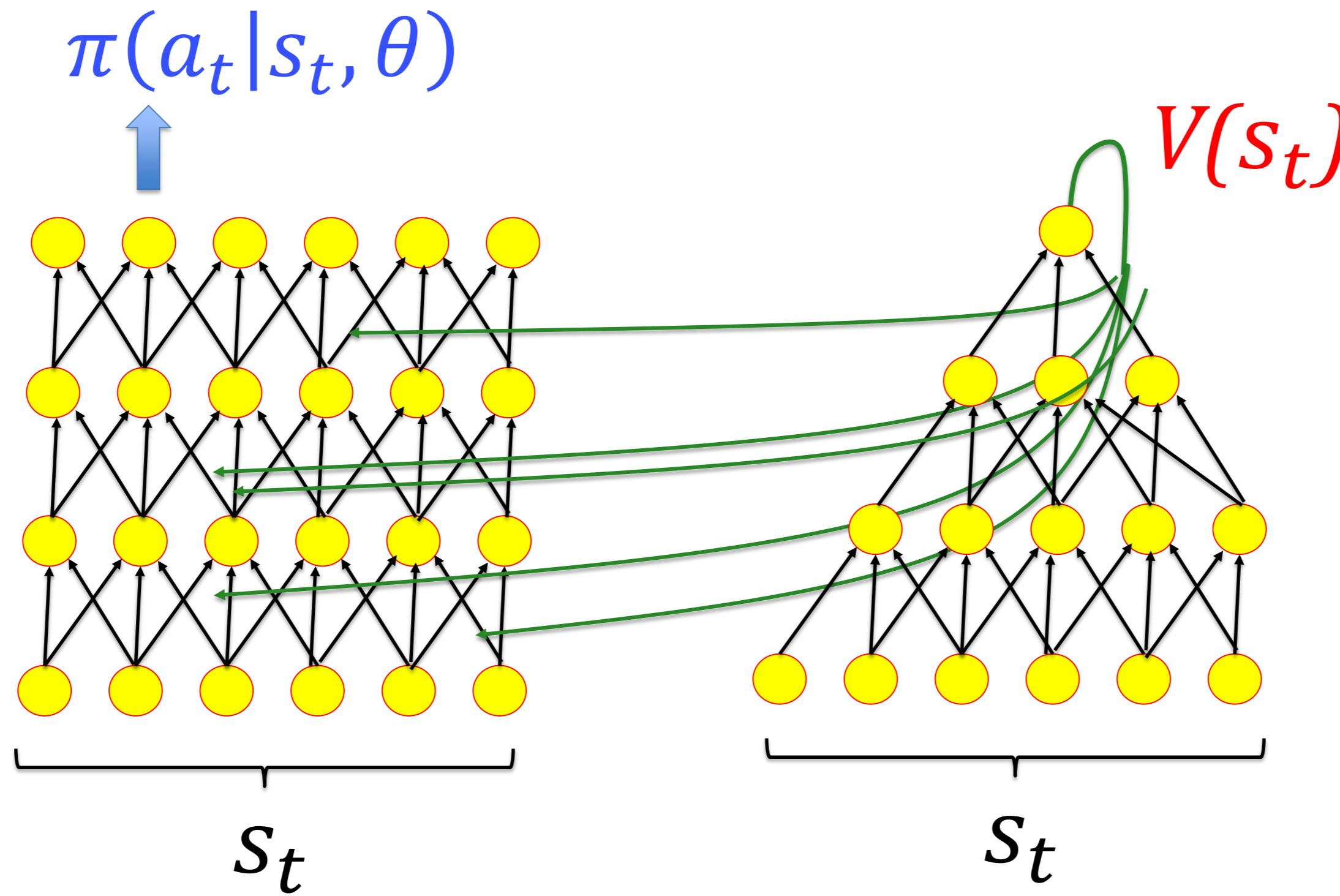

Learning signal:
[actual Return - $V(s)$]

(previous slide)

Both actor and critic are optimized by changing the parameters according to a gradient descent rule.

Gradient descent in a multi-layer network is called BackProp or Deep Learning.

We start with Deep Learning next week. Algorithm in pseudocode taken from the book of Sutton and Barto.

For the actor, the algorithm evaluates terms of the form

Outlook: Deep reinforcement learning: alpha-zero

Network for choosing action

action:

Advance king

2^e output for **value** of state:

output ↑ ↑ ↑ ↑ ↑

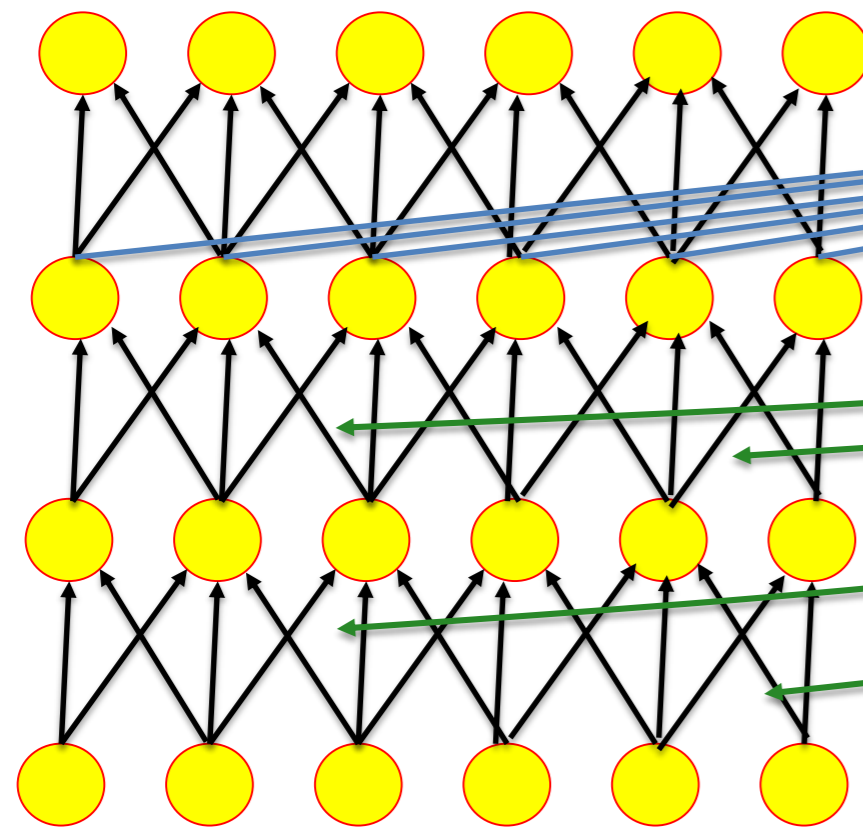

$V(s)$

learning:

→ change connections

aims:

- learn value $V(s)$ of position
- learn action policy to win

Learn $V(s)$ with TD learning!

input

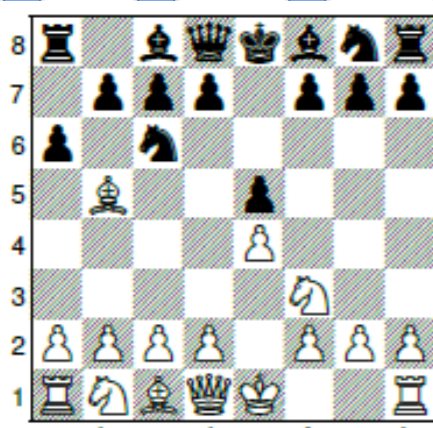

(previous slide)

Very schematically is this one of the ideas of deep reinforcement learning. We construct a deep network with multiple layers. We use the output units for action choice and optimize the parameters via policy gradient. We have a further output unit to estimate the V -value, and use it as a bias.

- The model of the V -value can share some units with the model of the actions
- The model of the V -value can be learned with tools from TD learning

This gives rise to actor-critic and 'advantage actor critic', to be discussed in the lecture on Deep Reinforcement Learning.

Learning outcomes and Conclusions:

- **basic idea of policy gradient: learn actions, not Q-values**
 - gradient ascent of total expected discounted reward
- **log-likelihood trick: getting the correct statistical weight**
 - enables transition from batch to online
- **policy gradient algorithms**
 - updates of parameter propto $[R - V] \frac{d}{d\theta_j} \ln[\pi]$ (several terms)
- **why subtract the mean reward?**
 - reduces noise of the online stochastic gradient
- **Reinforce with baseline**
 - a further output to subtract the mean reward

$$[R(s) - V(s)] \frac{d}{d\theta_j} \ln[\pi]$$

(previous slide) Your notes

Quiz: Policy Gradient and Reinforcement learning

Your friend has followed over the weekend a tutorial in reinforcement learning and claims the following. Is she right?

Even some policy gradient algorithms use V-values

V-values for policy gradient are calculated in a separate network (but some parameters can be shared with the actor network)

Teaching monitoring – monitoring of understanding

The End

[] today, up to here, at least 60% of material was new to me.

[] up to here, I have the feeling that I have been able to follow (at least) 80% of the lecture.