

Stellar orbits

2nd part

Outlines

Examples of orbits in spherical potentials

- Keplerian orbits
- orbits in an homogeneous sphere
- important remarks

Orbits in axisymmetric potentials

- orbits in the equatorial plane
- orbits outside the equatorial plane
- equations of motion
- orbits in the meridian plane
- examples

Nearly circular orbits

- Epicycle frequencies

Stellar orbits

Spherical Systems

Examples

Examples

① Kepler potential (potential of a mass point)

$$\left\{ \begin{array}{l} \phi(r) = -\frac{GM}{r} \\ \frac{\partial \phi}{\partial r}(r) = \frac{GM}{r^2} = GMu^2 \end{array} \right.$$

$$\frac{d^2 u}{d\varphi^2} + u = \frac{1}{L^2 u^2} \frac{\partial \phi}{\partial r} \left(\frac{1}{u} \right)$$

\Rightarrow

$$\frac{d^2 u}{d\varphi^2} + u = \frac{GM}{L^2}$$

Harmonic equation,
with frequency 1

General solution

$$\frac{d^2 u}{d\varphi^2} + u = \frac{GM}{L^2}$$

$$u(\varphi) = C \cos(\varphi - \varphi_0) + \frac{GM}{L^2}$$

free parameter free parameter

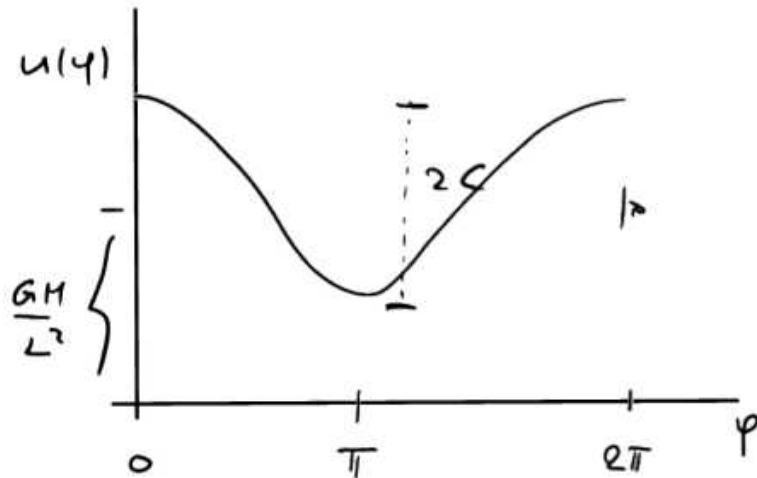

$$\text{period} = 2\pi$$

In term of r

$$r(\varphi) = \frac{1}{C \cos(\varphi - \varphi_0) + \frac{GM}{L^2}}$$

Introducing

$$\left\{ \begin{array}{l} e = \frac{CL^2}{GM} \quad \text{eccentricity} \\ a = \frac{L^2}{GM(1-e^2)} \quad \text{semi-major axis} \end{array} \right.$$

evaluate u and $\frac{du}{dt}$ for $\varphi = \varphi_0$ $\left(u(\varphi) = C + \frac{GM}{L^2} \quad \frac{du(\varphi)}{dt} = 0 \right)$

+ using $\frac{d^2u}{d\varphi^2} + u = \frac{1}{L^2 u^2} \frac{d\phi}{dr} \left(\frac{1}{u} \right)$

$$\left\{ \begin{array}{l} r(\varphi) = \frac{a(1-e^2)}{1+e \cos(\varphi-\varphi_0)} \\ \bar{E} = -\frac{GM}{2a} \end{array} \right.$$

↳ from the energy equation

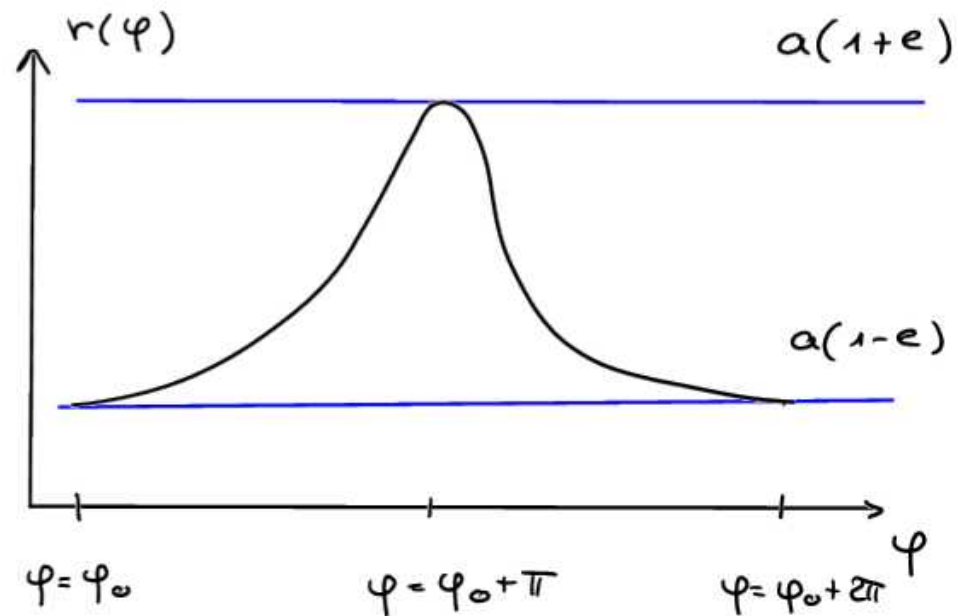

Cases

$$r(\varphi) = \frac{a(1 - e^2)}{1 + e \cos(\varphi - \varphi_0)}$$

$e \gg 1$

unbound orbit as $1 + e \cos(\varphi - \varphi_0)$ can be $= 0$
 $\Rightarrow r \rightarrow \infty$

$e < 1$

bound orbit (ellipse)

EXERCICE

pericenter / apocenter

$$r_{\min} = \frac{a(1 - e^2)}{1 + e} = a(1 - e)$$

$$r_{\max} = \frac{a(1 - e^2)}{1 - e} = a(1 + e)$$

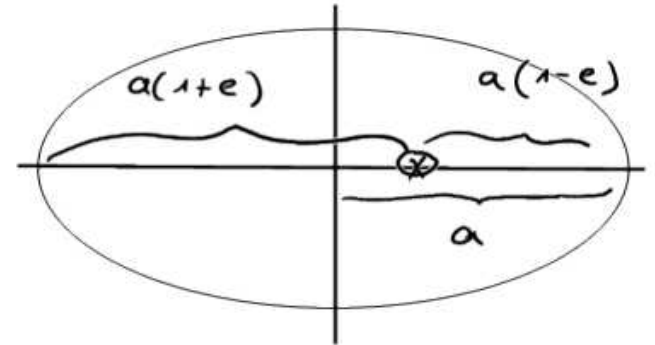

$e = 0$

$$r_{\min} = r_{\max} = a \quad (\text{circular orbit})$$

Kepler laws (1609-1619) :

EXERCICE

- The orbit of a planet is an ellipse with the Sun at one of the two foci.
- A line segment joining a planet and the Sun sweeps out equal areas during equal intervals of time.
- The square of a planet's orbital period is proportional to the cube of the length of the semi-major axis of its orbit.

Radial and azimuthal periods:

$$T_r = T_\phi$$

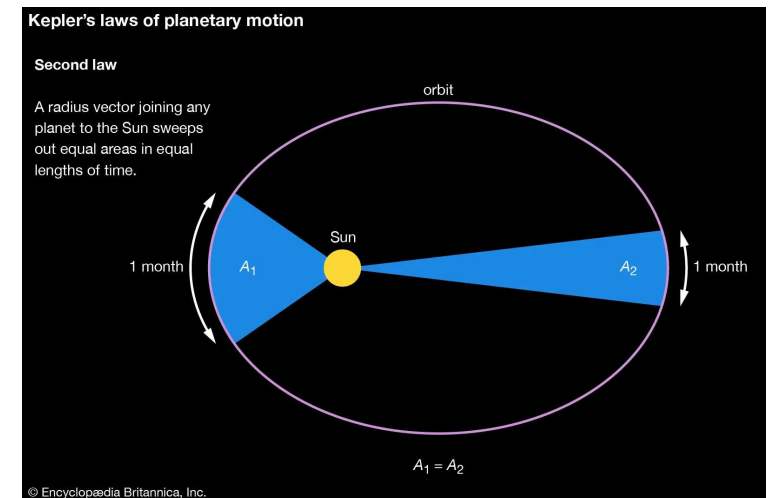

Keplerian orbits (point mass)

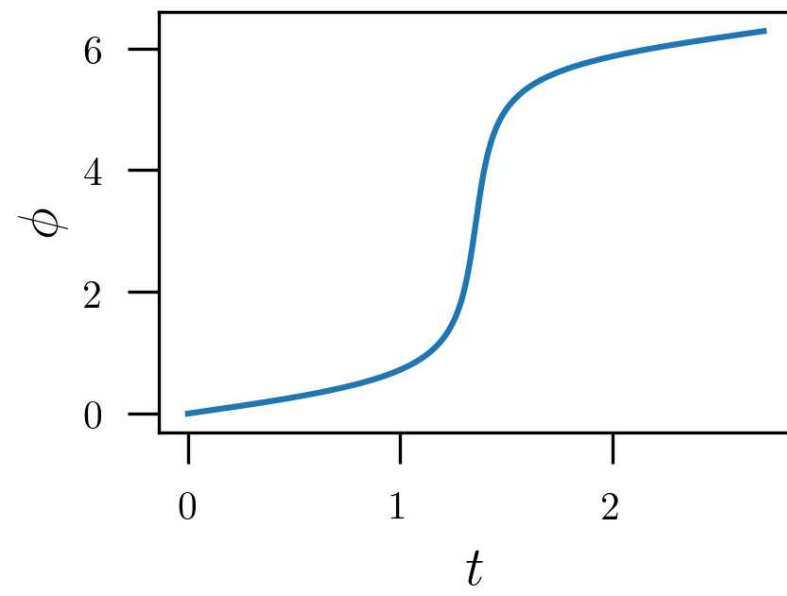
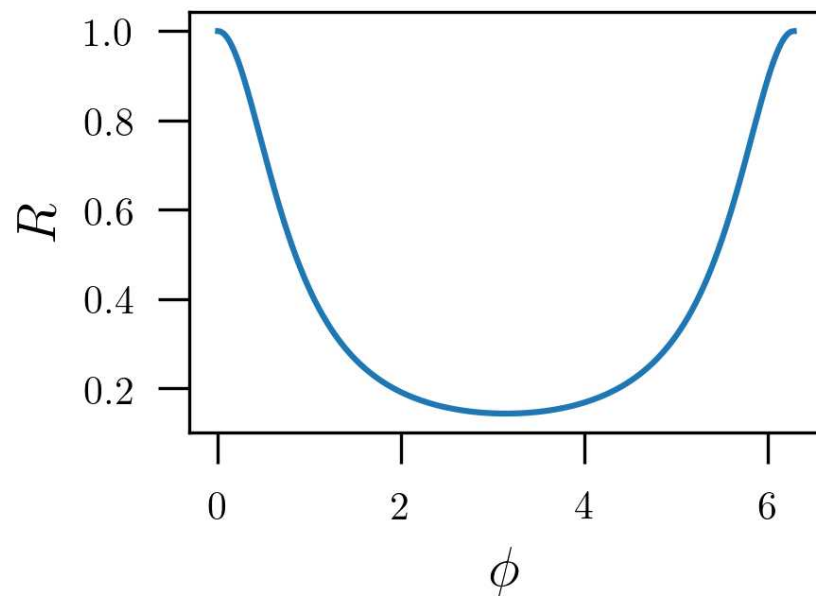
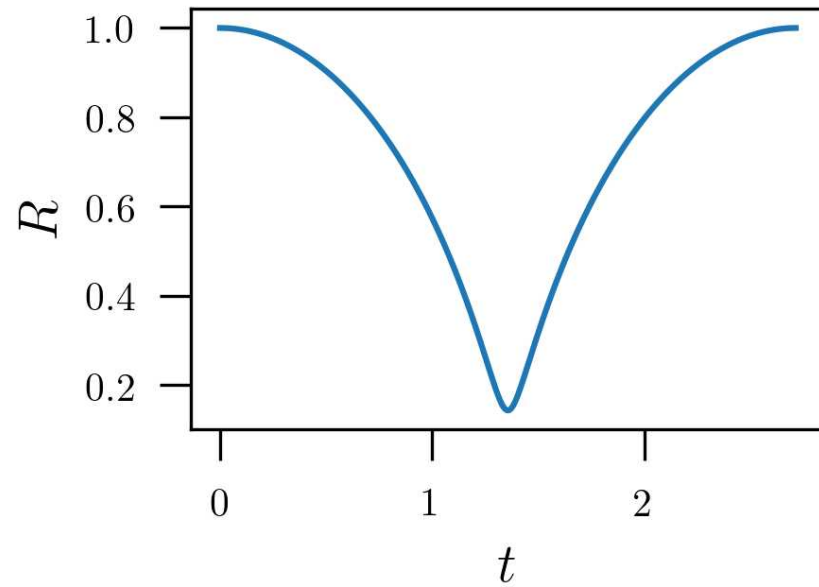
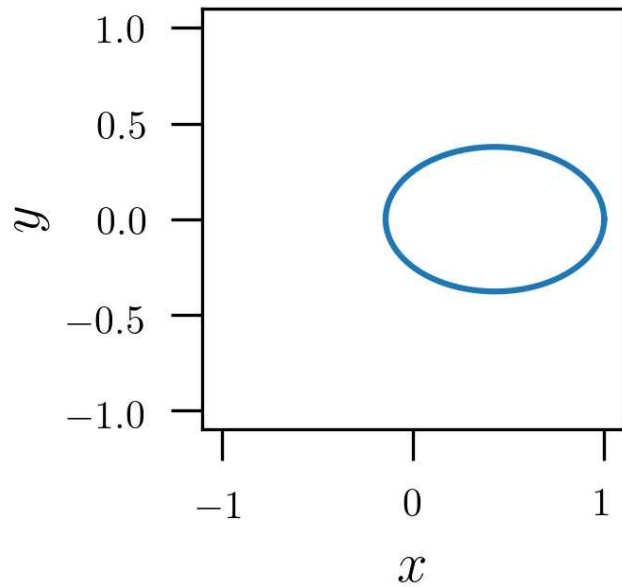

Keplerian orbits (point mass)

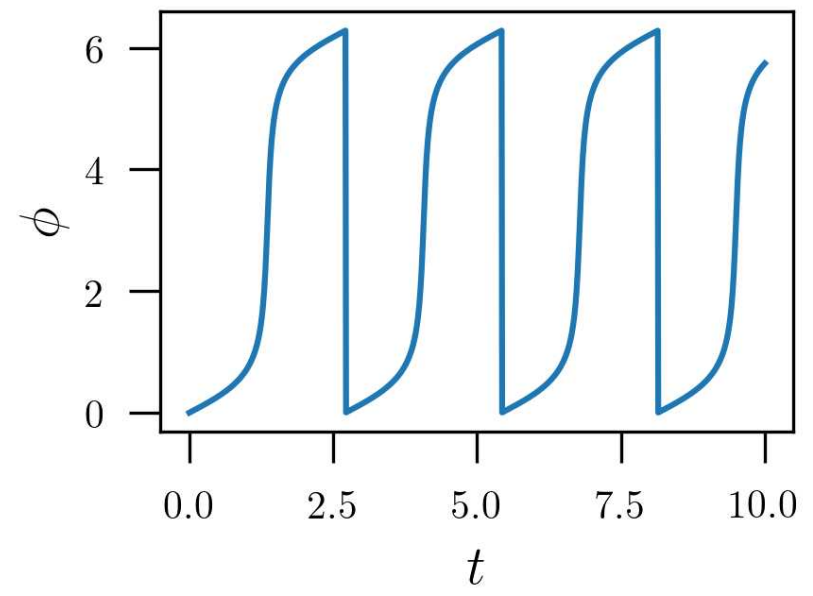
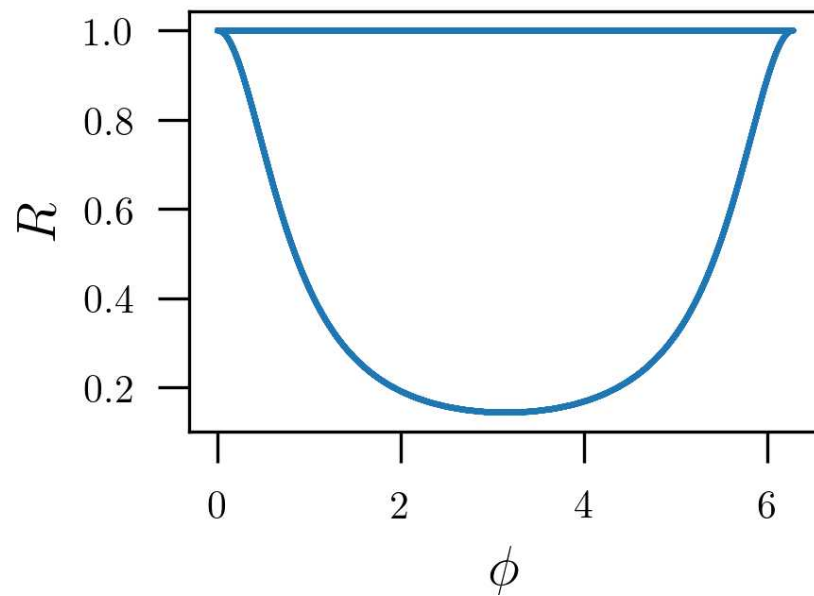
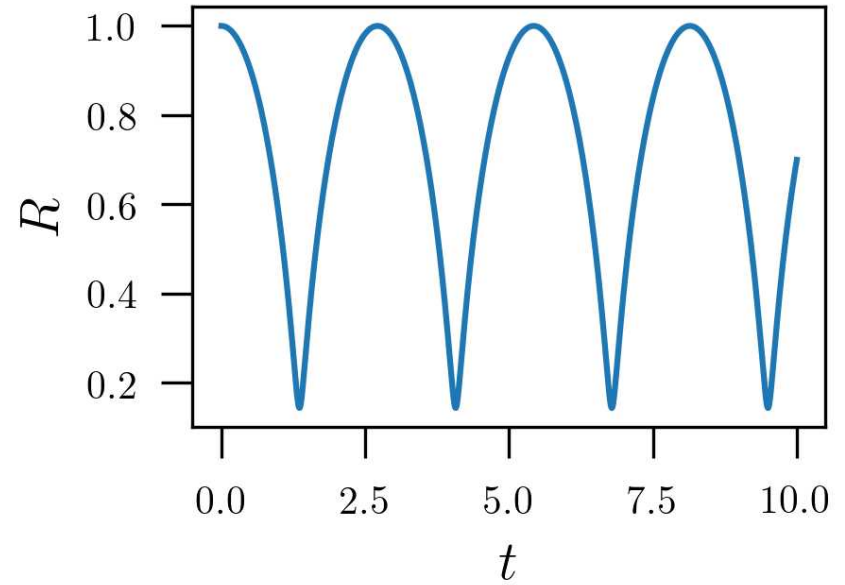
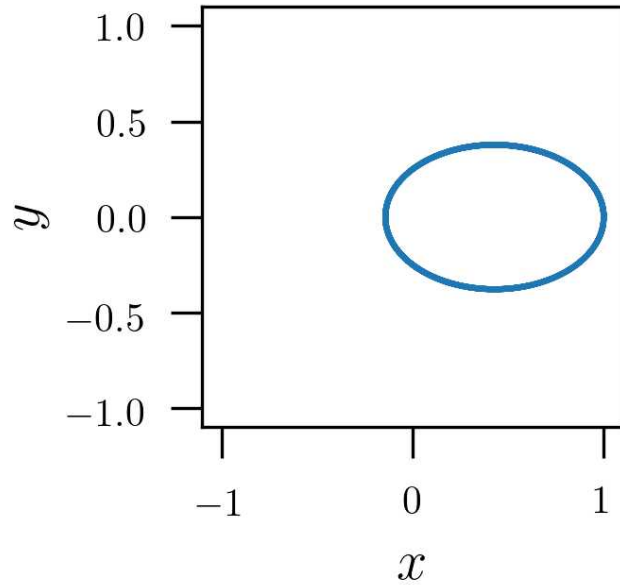

Keplerian orbits (point mass)

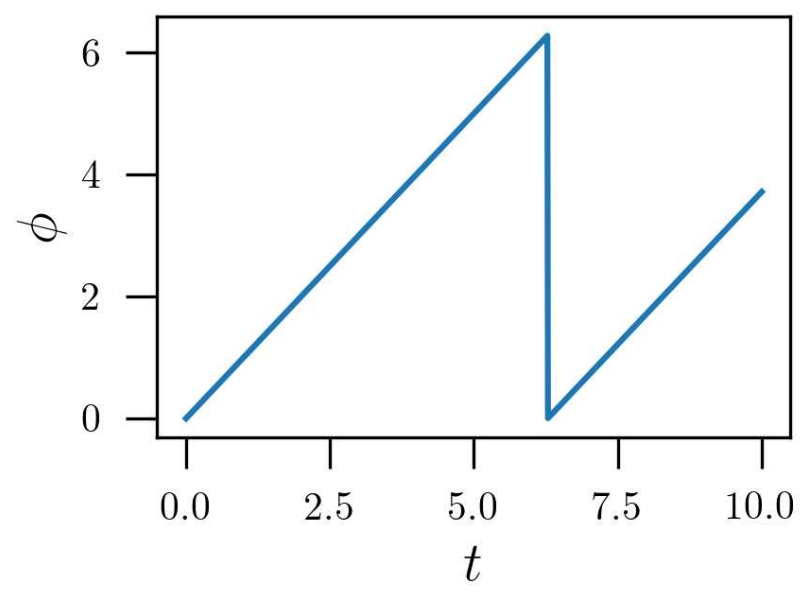
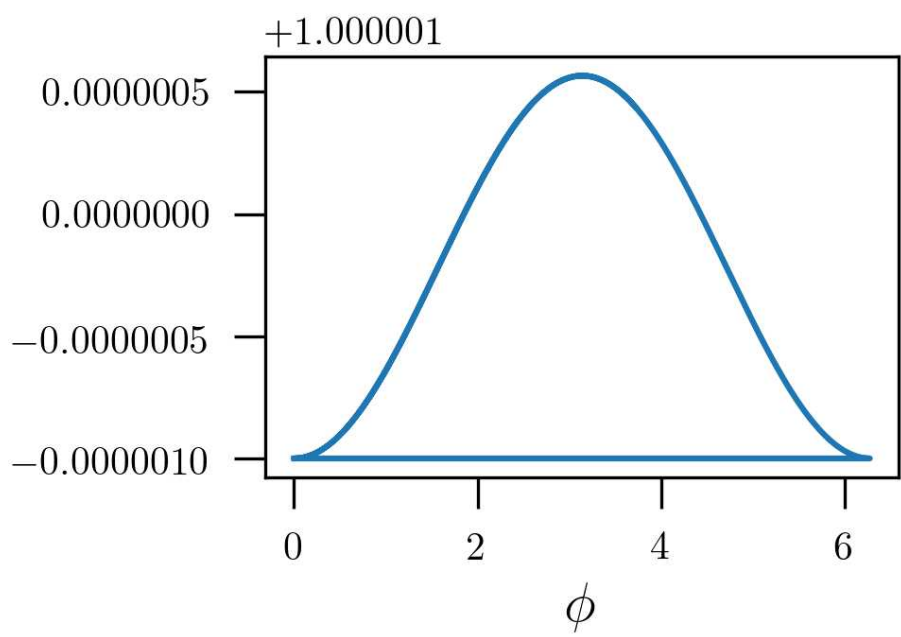
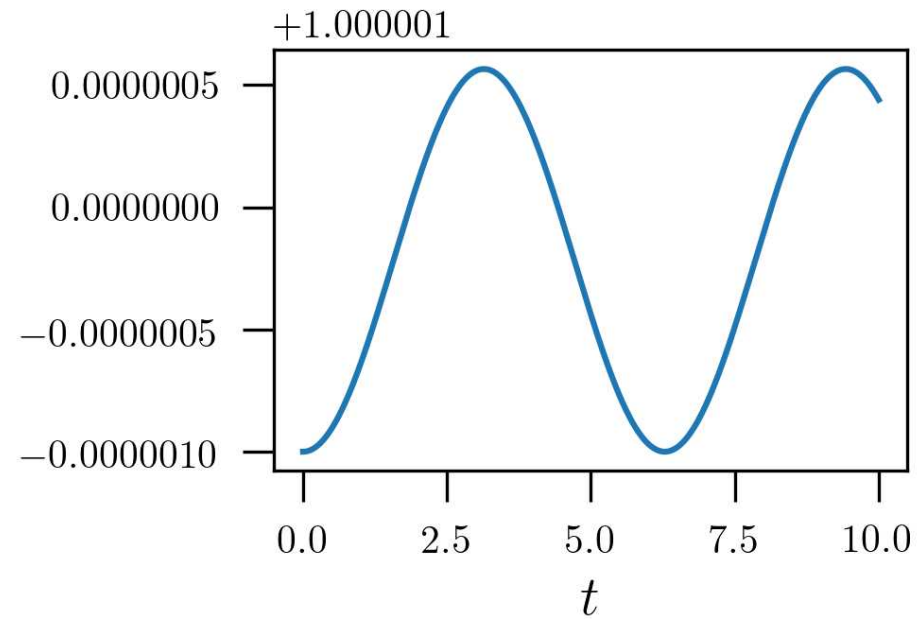
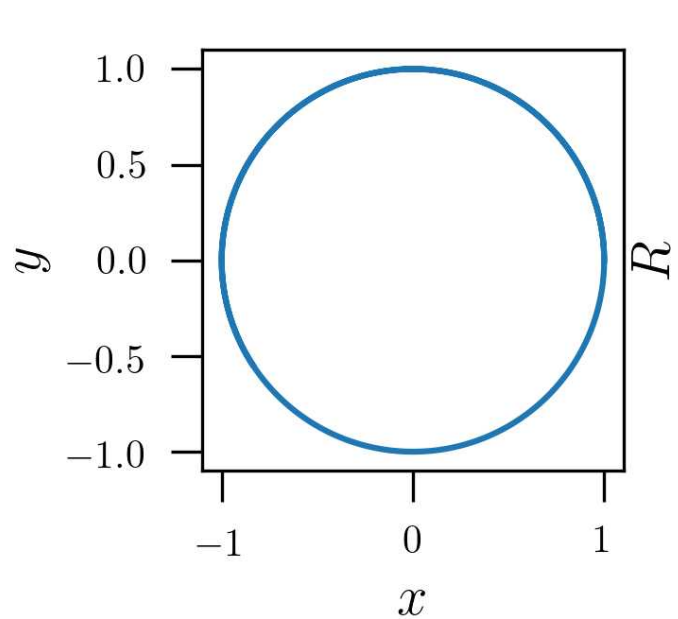

② Homogeneous sphere ρ_0, R_0 (Harmonic oscillations)

$$\phi(r) = \underbrace{-2\pi G \rho_0 R_0^2}_{\text{cte} \rightarrow 0} + \frac{2}{3} \pi G \rho_0 r^2$$

$$\underline{\phi(r) = \frac{1}{2} \Omega^2 r^2} \quad \text{with } \Omega = \sqrt{\frac{4}{3} \pi G \rho_0}$$

Equations of motion (in cartesian coordinates)

$$L(x, y, \dot{x}, \dot{y}) = \frac{1}{2} \dot{x}^2 + \frac{1}{2} \dot{y}^2 - \frac{1}{2} \Omega^2 (x^2 + y^2)$$

$$\begin{cases} \ddot{x} = -\Omega^2 x \\ \ddot{y} = -\Omega^2 y \end{cases} \quad \begin{cases} x(t) = X \cos(\Omega t + \varepsilon_x) \\ y(t) = Y \cos(\Omega t + \varepsilon_y) \end{cases}$$

$X, Y, \varepsilon_x, \varepsilon_y$ constants fixed by the initial conditions

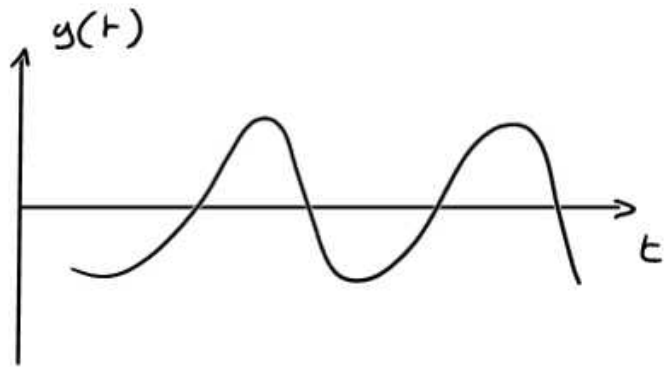
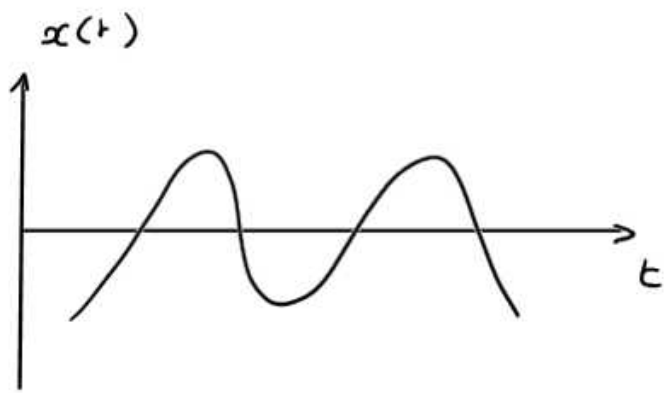

same period

\Rightarrow closed orbits (ellipse)

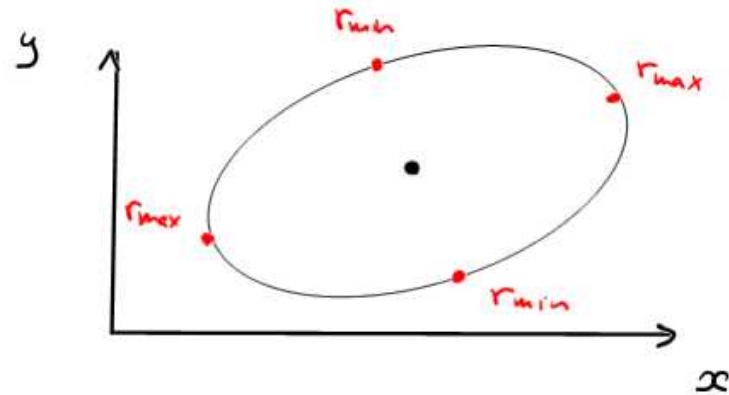

Periods

$$T_{\varphi} = \frac{2\pi}{\Omega}$$

$$T_r = \frac{1}{2} T_{\varphi} = \frac{\pi}{\Omega}$$

Homogeneous sphere (harmonic)

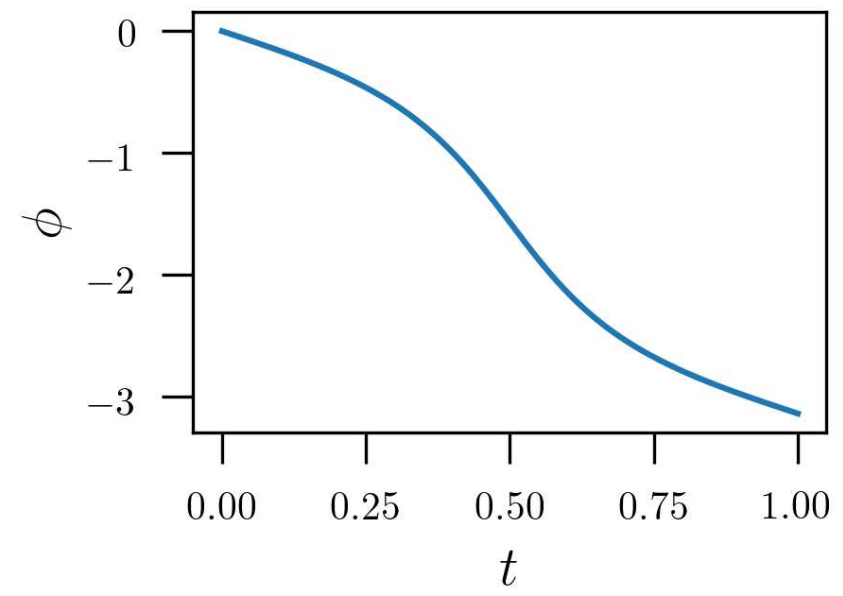
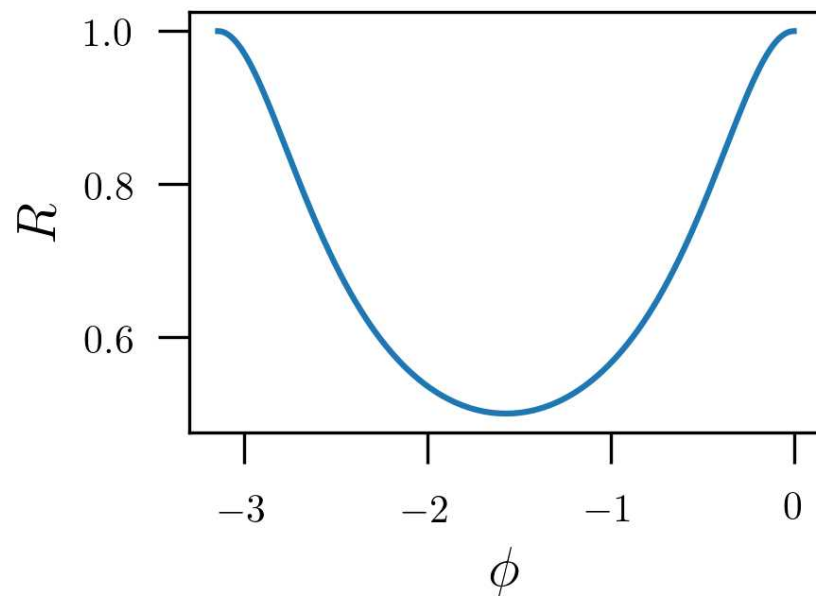
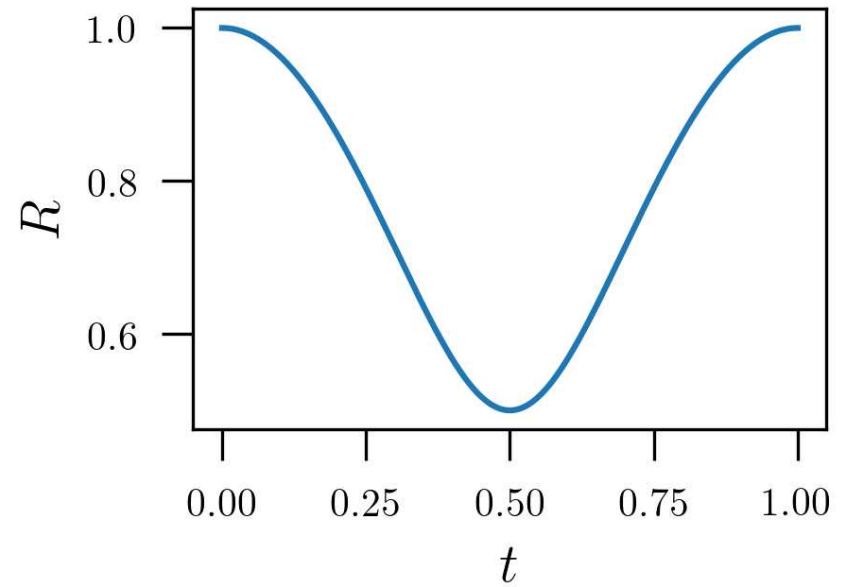
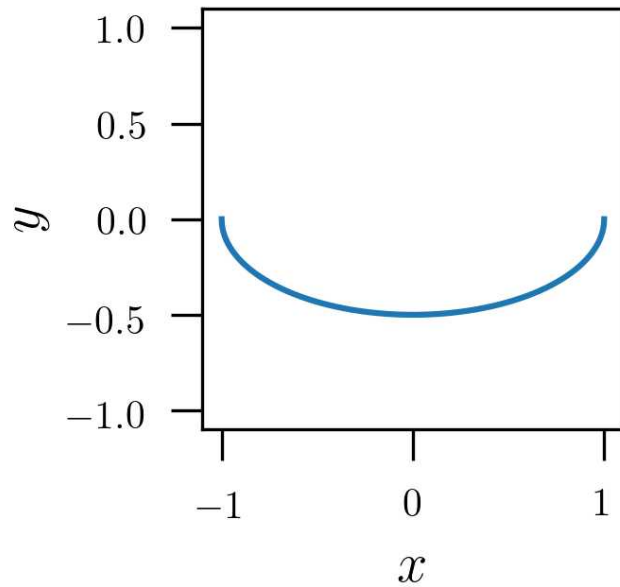

Homogeneous sphere (harmonic)

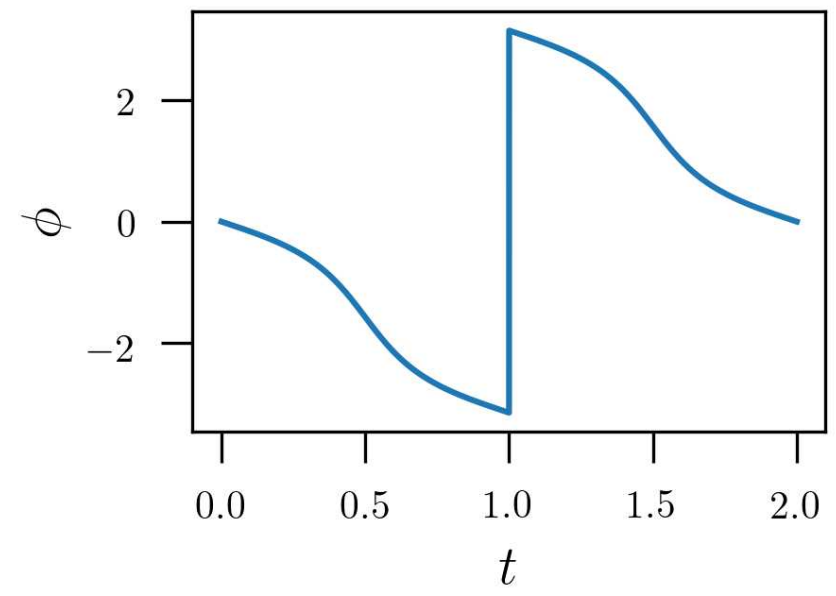
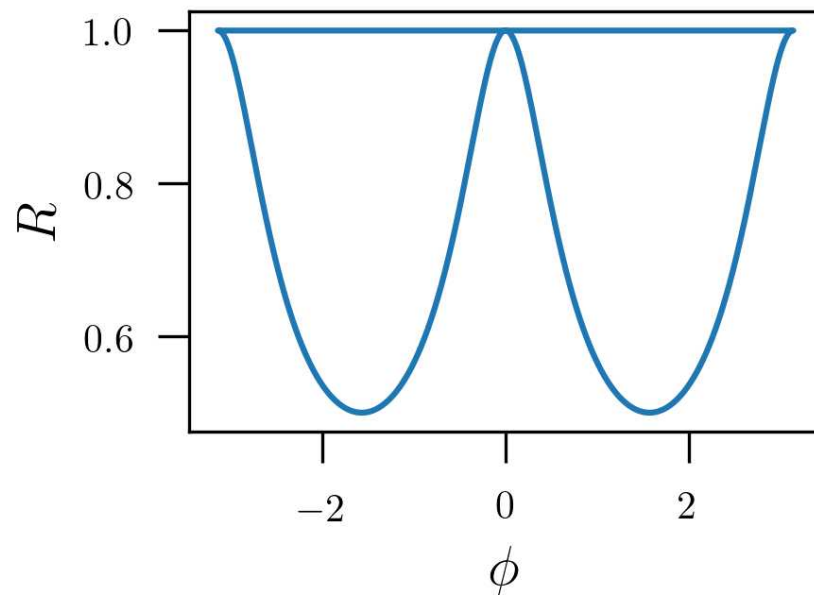
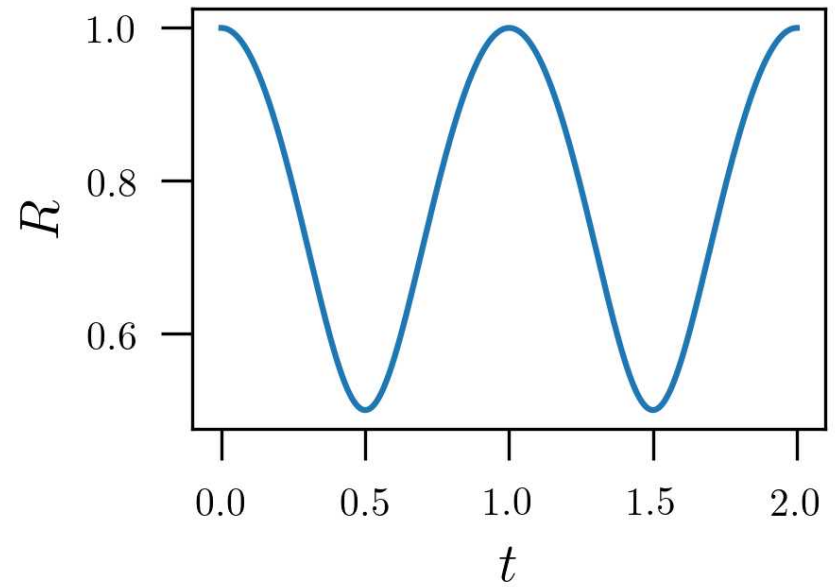
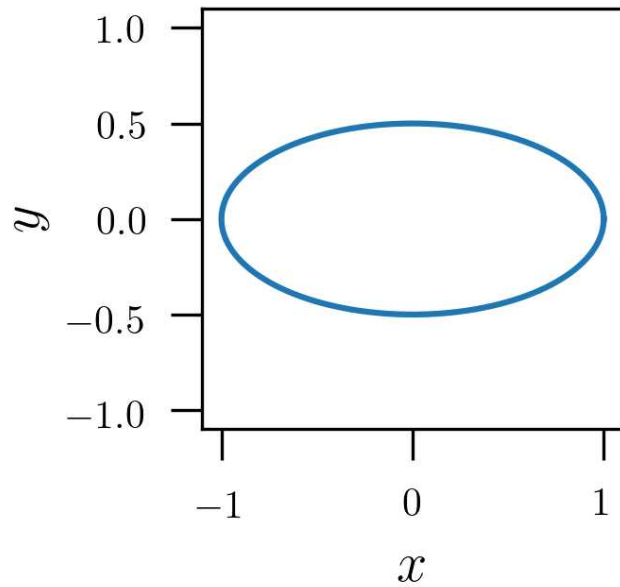

Homogeneous sphere (harmonic)

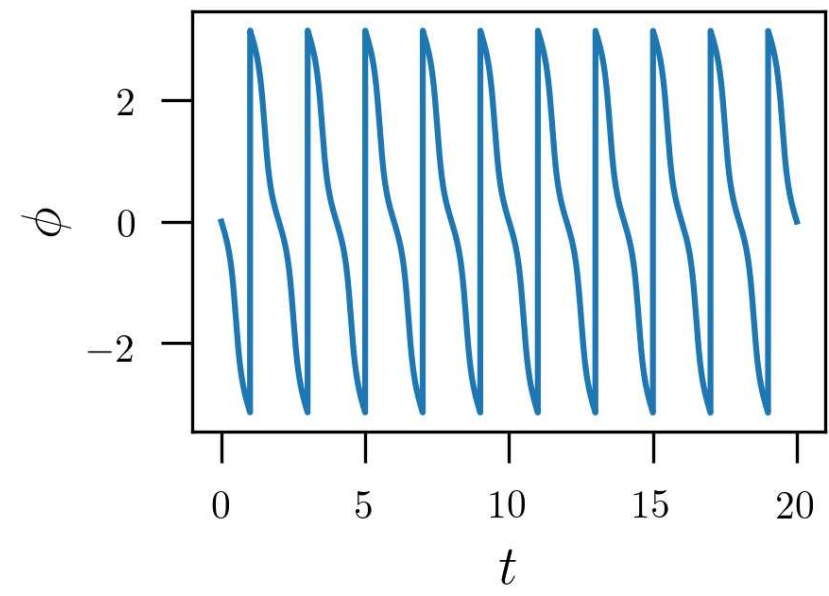
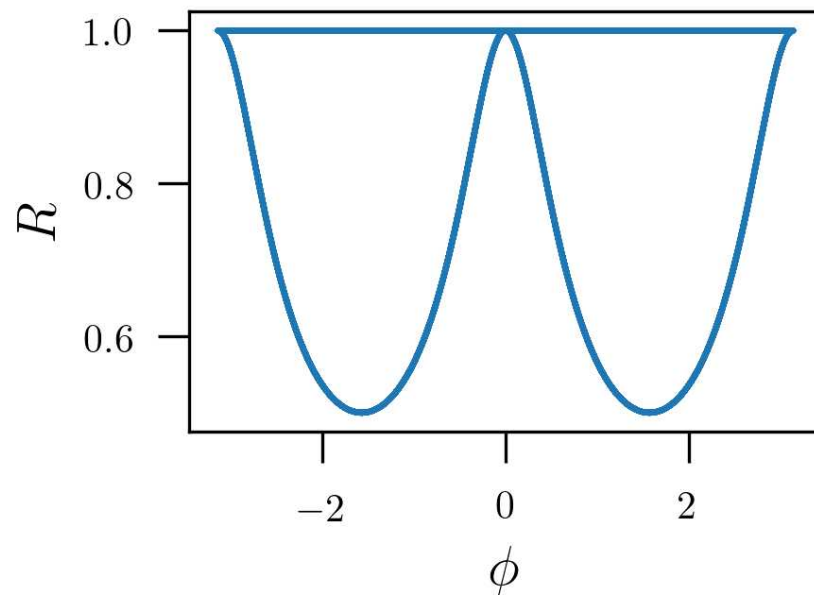
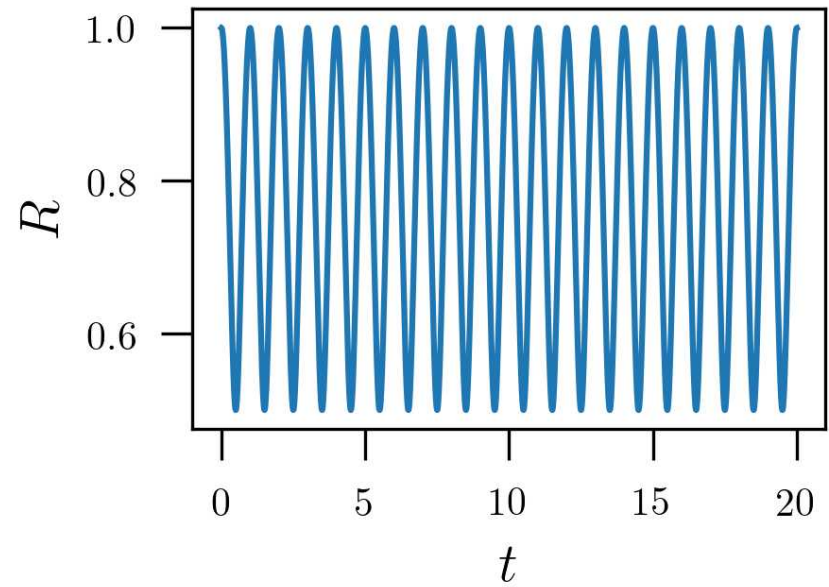
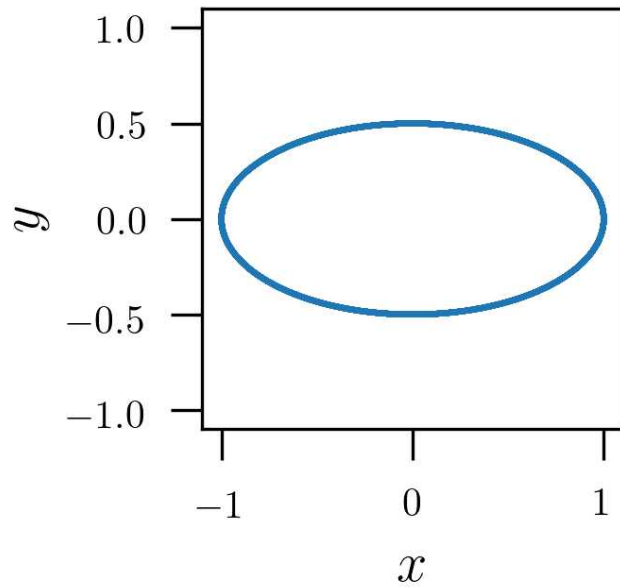

Important Remarks

Homogeneous sphere

$$T_r = \frac{1}{2} T_\varphi$$

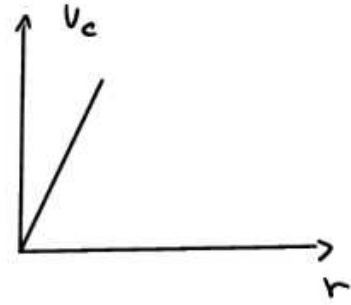
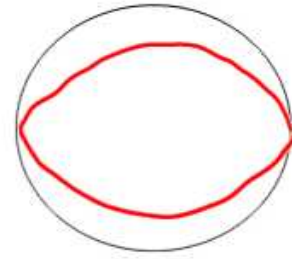
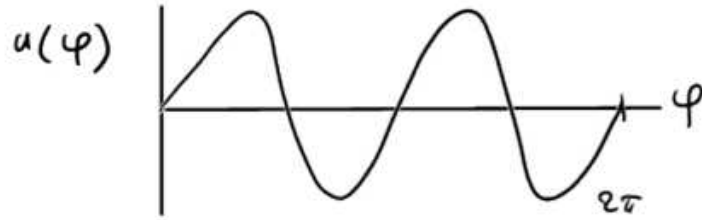

Important Remarks

Homogeneous sphere

$$T_r = \frac{1}{2} T_\varphi$$

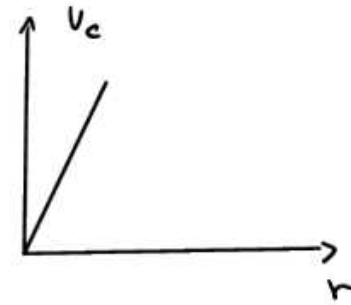
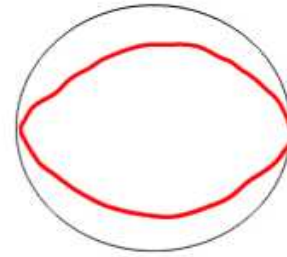
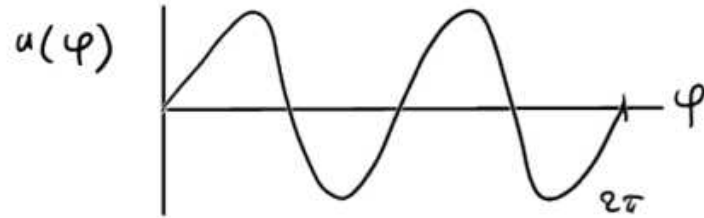

Keplerian potential

$$T_r = T_\varphi$$

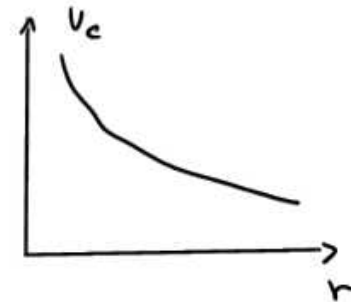
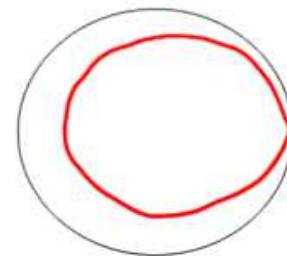
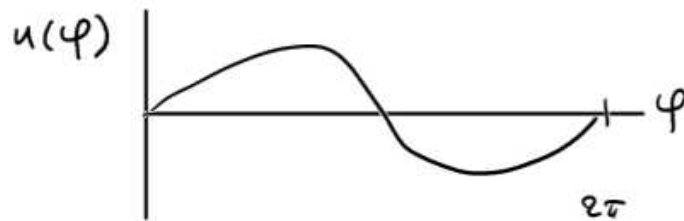

Important Remarks

Homogeneous sphere

$$T_r = \frac{1}{2} T_\varphi$$

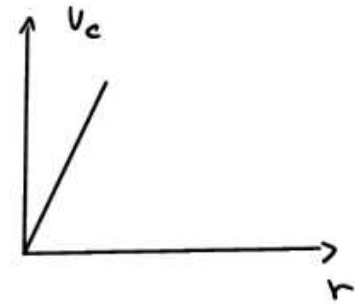
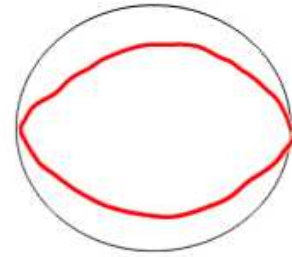
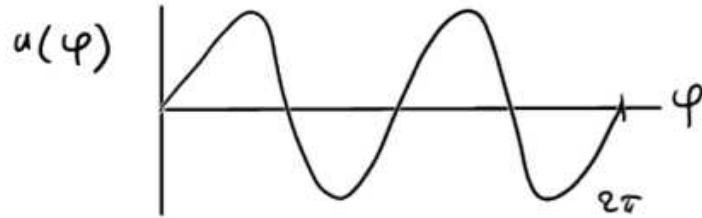

Galaxy

$$\frac{1}{2} T_\varphi < T_r < T_\varphi$$

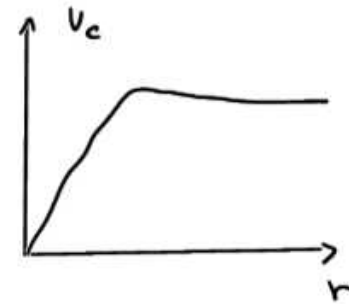
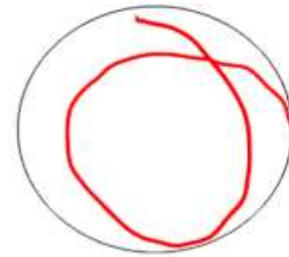
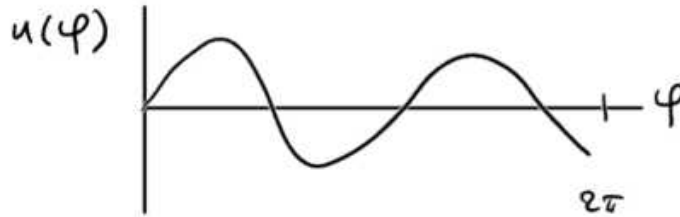

Keplerian potential

$$T_r = T_\varphi$$

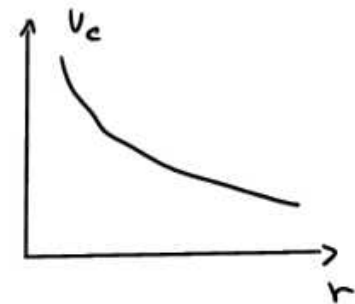
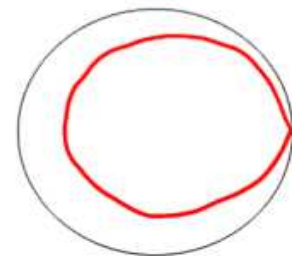
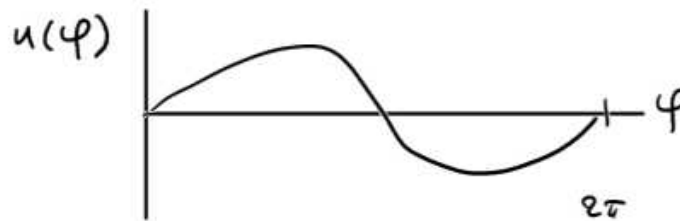

Stellar orbits

Axisymmetric Systems

Orbits in axisymmetric potentials

Axisymmetric potential

$$\phi(\vec{x}) = \phi(R, |z|)$$

- symmetry of revolution around z
- reflection symmetry with respect to the $z=0$ plane

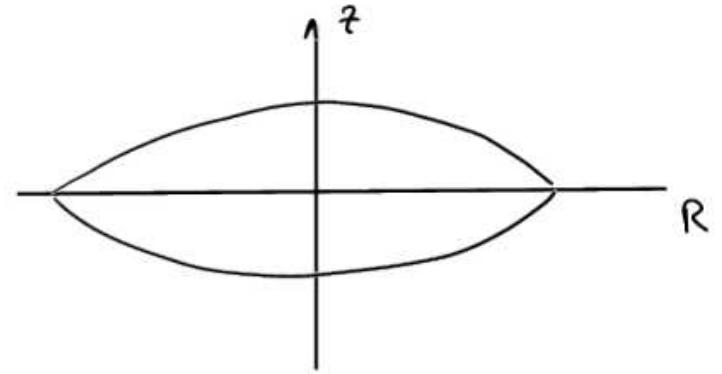

Definitions

Oblate systems : c , the semi-minor axis is parallel to \vec{z}

Prolate systems : a , the semi-major axis is parallel to \vec{z}

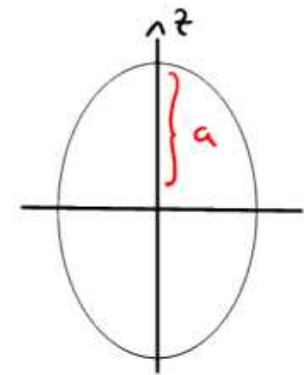
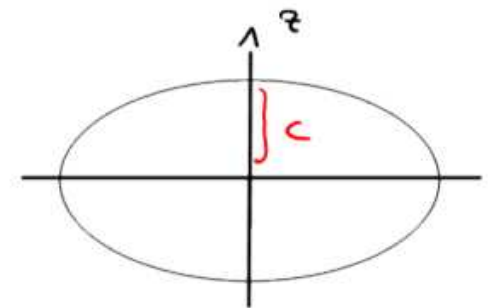

Description of the dynamics

Cylindrical coordinates

(R, θ, z)

Orbits in the equatorial plane

$\forall t, \underline{z = 0}$

$$\phi(R, |z|=0) \equiv \phi(R)$$

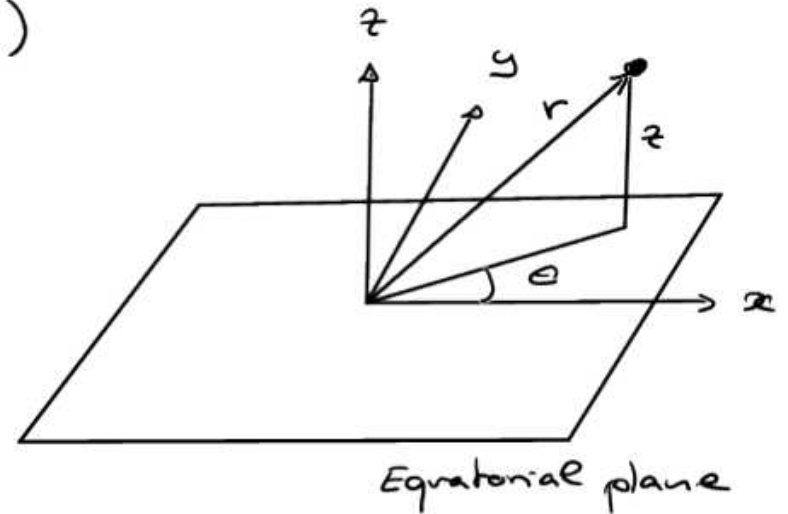

The potential seen by the stars is similar to a spherical potential

- description of the orbits in polar coordinates r, φ
- recycle all results developed for spherical potentials

Torque and angular momentum

$$\begin{cases} \dot{\vec{e}}_R = \dot{\theta} \vec{e}_\theta \\ \dot{\vec{e}}_\theta = -\dot{\theta} \vec{e}_R \\ \dot{\vec{e}}_z = 0 \end{cases}$$

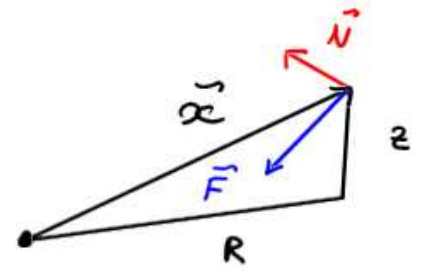

$$\begin{cases} \vec{x} = R \vec{e}_R + z \vec{e}_z \\ \vec{v} = \dot{R} \vec{e}_R + R \dot{\theta} \vec{e}_\theta + \dot{z} \vec{e}_z \\ \vec{F} = -\vec{\nabla} \phi = -\frac{\partial \phi}{\partial R} \vec{e}_R - \frac{1}{R} \frac{\partial \phi}{\partial \theta} \vec{e}_\theta - \frac{\partial \phi}{\partial z} \vec{e}_z \end{cases}$$

Torque

$$\begin{aligned} \vec{N} &= \vec{x} \times \vec{F} = (R \vec{e}_R + z \vec{e}_z) \times \left(-\frac{\partial \phi}{\partial R} \vec{e}_R - \frac{\partial \phi}{\partial z} \vec{e}_z \right) \\ &= \left(z \frac{\partial \phi}{\partial R} - R \frac{\partial \phi}{\partial z} \right) \vec{e}_\theta \end{aligned}$$

Angular momentum

$$\vec{L} = \vec{x} \times \vec{v} = (R \vec{e}_R + z \vec{e}_z) \times (\dot{R} \vec{e}_R + R \dot{\theta} \vec{e}_\theta + \dot{z} \vec{e}_z)$$

$$= \underbrace{-zR\dot{\theta}}_{L_R} \vec{e}_R + \underbrace{(z\dot{R} - R\dot{z})}_{L_\theta} \vec{e}_\theta + \underbrace{R^2\dot{\theta}}_{L_z} \vec{e}_z$$

$$\frac{d\vec{L}}{dt} = (\dot{L}_R - L_\theta \dot{\theta}) \vec{e}_R + (\dot{L}_\theta + L_R \dot{\theta}) \vec{e}_\theta + \dot{L}_z \vec{e}_z$$

\swarrow $\frac{d\vec{L}}{dt} = \vec{N}$

$$= \left(z \frac{\partial \phi}{\partial R} - R \frac{\partial \phi}{\partial z} \right) \vec{e}_\theta$$

So:

- \vec{e}_R : $\dot{L}_R - L_\theta \dot{\theta} = 0 = \frac{d}{dt}(-zR\dot{\theta}) - (z\dot{R} - R\dot{z})\dot{\theta} = 0$
 $\Rightarrow R^2\dot{\theta} = cte$

- \vec{e}_z : $\dot{L}_z = 0 = R^2\dot{\theta}$
 $\Rightarrow R^2\dot{\theta} = cte$

The z -component of the angular momentum is conserved

Orbits that moves outside the equatorial plane

Cylindrical coordinates

$$\begin{cases} x = R \cos \theta & \dot{x} = \dot{R} \cos \theta - R \sin \theta \dot{\theta} \\ y = R \sin \theta & \dot{y} = \dot{R} \sin \theta + R \cos \theta \dot{\theta} \\ z = z & \dot{z} = \dot{z} \end{cases}$$

$$\underline{\dot{x}^2 + \dot{y}^2 = \dot{R}^2 + R^2 \dot{\theta}^2}$$

Lagrangian (specific) in cylindrical coordinates

$$\mathcal{L} = \frac{1}{2} (\dot{x}^2 + \dot{y}^2) + \phi(\sqrt{x^2 + y^2}) = \frac{1}{2} (\dot{R}^2 + R^2 \dot{\theta}^2 + \dot{z}^2) - \phi(R, z)$$

Lagrange equations

$$\frac{d}{dt} \left(\frac{\partial \mathcal{L}}{\partial \dot{\vec{q}}} \right) - \frac{\partial \mathcal{L}}{\partial \vec{q}} = 0$$

$$\vec{q} = \begin{cases} R \\ \theta \\ z \end{cases} \quad \dot{\vec{q}} = \begin{cases} \dot{R} \\ \dot{\theta} \\ \dot{z} \end{cases}$$

Lagrange equations

$$\begin{cases} \ddot{R} = R\dot{\theta}^2 & - \frac{\partial \phi}{\partial R} & \textcircled{1} \\ \frac{d}{dt}(R^2\dot{\theta}) = & \left(-\frac{\partial \phi}{\partial \theta}\right) = 0 & \textcircled{2} \\ \ddot{z} = & - \frac{\partial \phi}{\partial z} & \textcircled{3} \end{cases}$$

$$\textcircled{2} \quad R^2\dot{\theta} = \text{cte} = L_z$$

The z -component of the angular momentum is conserved

Solution

$$\theta(t) = L_z \int_{t_0}^{t_1} \frac{1}{R^2(t)} dt$$

$\textcircled{1} + \textcircled{3}$ two coupled through $\phi(R, z)$ equations for R and z

Hamiltonian/Energy

$$H(\vec{q}, \vec{p}, t) := \vec{p} \cdot \dot{\vec{q}} - \mathcal{L}(\vec{q}, \dot{\vec{q}}, t)$$

$$\vec{q} = \begin{cases} R \\ \theta \\ z \end{cases} \quad \dot{\vec{q}} = \begin{cases} \dot{R} \\ \dot{\theta} \\ \dot{z} \end{cases}$$

$$\vec{p} = \begin{cases} \frac{\partial \mathcal{L}}{\partial \dot{R}} = \dot{R} \\ \frac{\partial \mathcal{L}}{\partial \dot{\theta}} = R^2 \dot{\theta} \\ \frac{\partial \mathcal{L}}{\partial \dot{z}} = \dot{z} \end{cases}$$

$$p_{\theta} = R^2 \dot{\theta} = L_z$$

$$H(R, \dot{R}, \theta, \dot{\theta}, z, \dot{z}) = \frac{1}{2} (\dot{R}^2 + R^2 \dot{\theta}^2 + \dot{z}^2) + \phi(R, z) = E$$

E (Energy) is conserved

as \mathcal{L} is time independent

ϕ

Effective potential

$$\text{with } L_z = R^2 \dot{\theta}$$

Definition

$$\phi_{\text{eff}}(R, z) = \phi(R, z) + \frac{L_z^2}{2R^2}$$

$$L_z^2 = R^4 \dot{\theta}^2$$

$$\left\{ \begin{array}{l} \frac{\partial \phi_{\text{eff}}}{\partial R} = \frac{\partial \phi}{\partial R} - \frac{L_z^2}{R^3} \equiv \frac{\partial \phi}{\partial R} - R \dot{\theta}^2 \\ \frac{\partial \phi_{\text{eff}}}{\partial z} = \frac{\partial \phi}{\partial z} \end{array} \right.$$

The equations of motion (1) + (3) becomes

$$\left\{ \begin{array}{l} \ddot{R} = - \frac{\partial \phi_{\text{eff}}}{\partial R}(R, z) \\ \ddot{z} = - \frac{\partial \phi_{\text{eff}}}{\partial z}(R, z) \end{array} \right.$$

The 3D motion of a star in an axisymmetric potential is reduced to a 2D motion in the meridian plane (R, z)

phase space $6D \rightarrow 4D$

Hamiltonian in the meridian plane

These equations of motion may be derived from the Lagrangian

$$\mathcal{L}(R, \dot{R}, z, \dot{z}) = \frac{1}{2} \dot{R}^2 + \frac{1}{2} \dot{z}^2 - \phi_{\text{eff}}(R, z)$$

The corresponding Hamiltonian writes $(p_R = \dot{R}, p_z = \dot{z})$

$$\begin{aligned} H(R, \dot{R}, z, \dot{z}) &= \frac{1}{2} (\dot{R}^2 + \dot{z}^2) + \phi_{\text{eff}}(R, z) \\ &= \frac{1}{2} (\dot{R}^2 + \dot{z}^2) + \phi(R, z) + \frac{L_z^2}{2R^2} \\ &= \frac{1}{2} (\dot{R}^2 + \dot{z}^2) + \phi(R, z) + \frac{1}{2} R^2 \dot{\theta}^2 = E \end{aligned}$$

kinetic energy
in the orbital
plane

E is conserved
as ϕ_{eff} is
time independent

orbit's
total energy

Illustration in the $z=0$ plane

for $R \rightarrow \infty$

$$\phi_{\text{eff}} = \phi + \underbrace{\frac{L^2}{2}}_{\rightarrow 0} \frac{1}{R^2} \sim \phi$$

for $R \rightarrow 0$

$$\phi_{\text{eff}} = \underbrace{\phi}_{\text{bounded}} + \underbrace{\frac{L^2}{2}}_{\text{diverges}} \frac{1}{R^2} \sim \frac{1}{R^2}$$

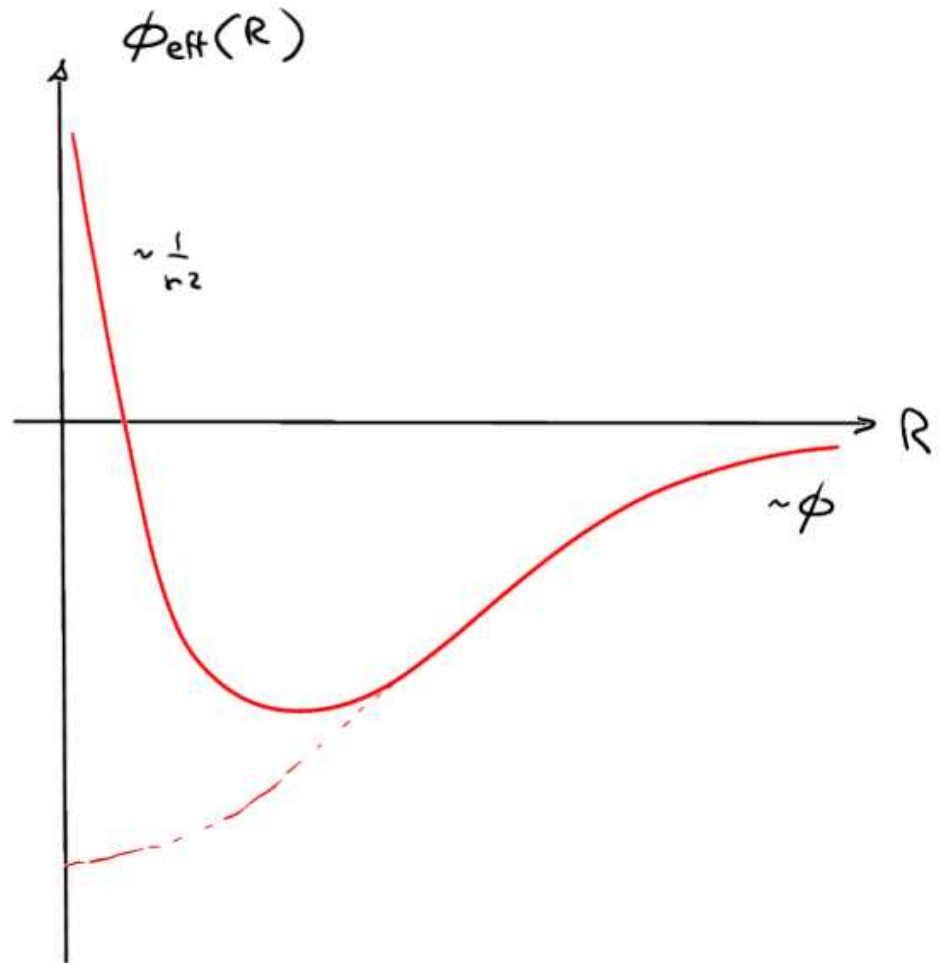
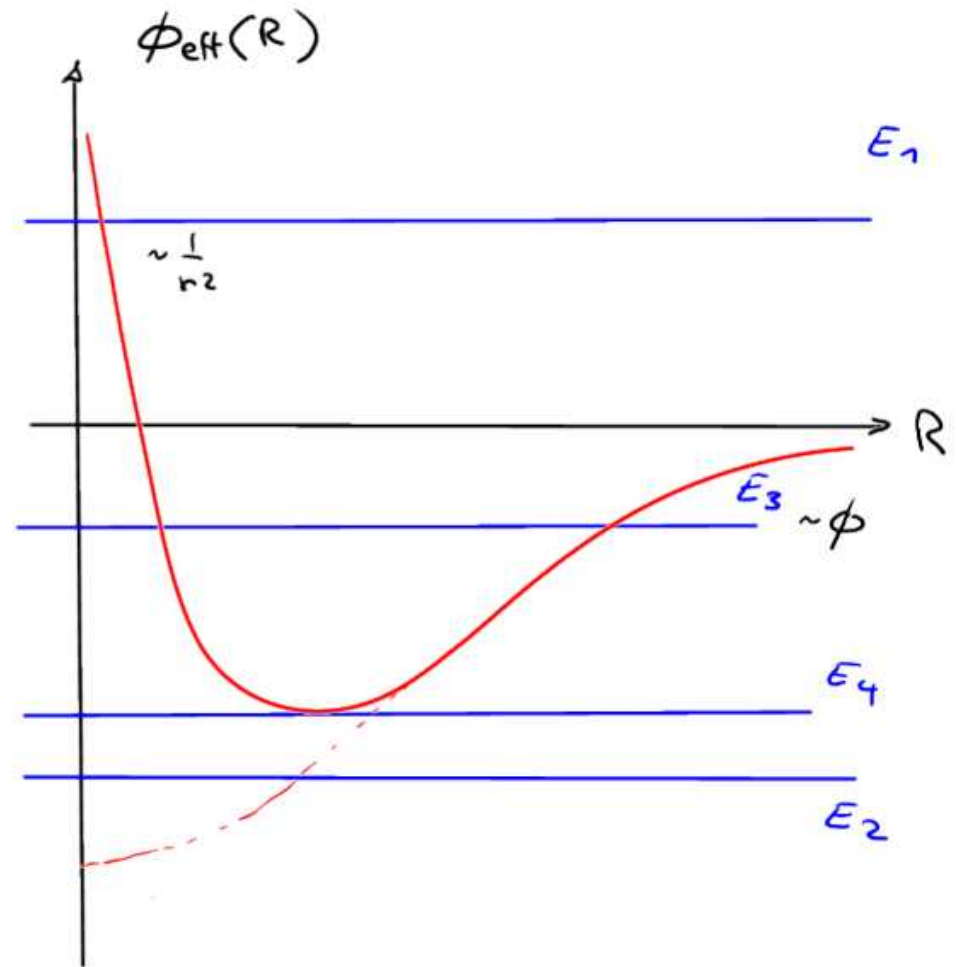

Illustration in the $z=0$ plane

$$E = \frac{1}{2} \dot{R}^2 + \phi_{\text{eff}}(R)$$

4 cases

- ① $E > \phi_{\text{eff}}(\infty)$ except at $E = \phi_{\text{eff}}$
 $\dot{R} \neq 0$ unbound orbits
- ② $E < \min(\phi_{\text{eff}}(R))$ $\dot{R}^2 < 0$
impossible
- ③ $\min(\phi_{\text{eff}}(R)) < E < \phi_{\text{eff}}(\infty)$
orbit bounded between R_1 and R_2 (where $\dot{R} = 0$)
- ④ $E = \min(\phi_{\text{eff}}(R))$ (stationary point)
 $R_1 = R_2$ (circular orbit)



Stationary point

$$\dot{R} = \ddot{R} = 0$$

$$\dot{z} = \ddot{z} = 0$$

from

$$\begin{cases} \ddot{R} = - \frac{\partial \phi_{\text{eff}}}{\partial R}(R, z) \\ \ddot{z} = - \frac{\partial \phi_{\text{eff}}}{\partial z}(R, z) \end{cases}$$

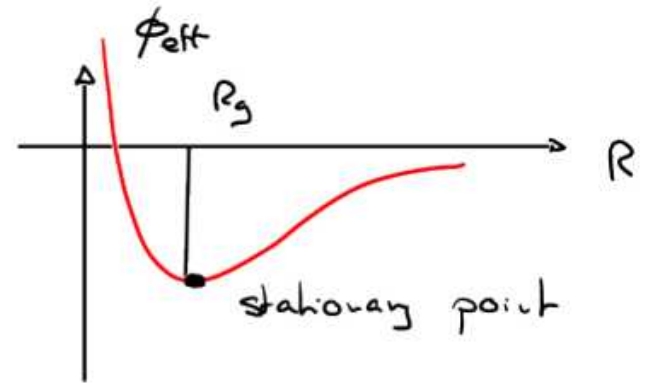

$$\begin{cases} \frac{\partial \phi_{\text{eff}}}{\partial R} = 0 & = \frac{\partial \phi}{\partial R} - \frac{L_z^2}{R^3} = 0 \\ \frac{\partial \phi_{\text{eff}}}{\partial z} = 0 & = \frac{\partial \phi}{\partial z} = 0 \end{cases}$$

→ by symmetry where $z=0$

$$R_g \text{ such that } \left. \frac{\partial \phi}{\partial R} \right|_{R_g, 0} = \frac{L_z^2}{R_g^3} = R_g e^2 \stackrel{V_g = R e^2}{=} \frac{V_e^2(R_g)}{R_g} = \frac{V_c^2(R_g)}{R_g}$$

$$V_c^2 = R \left. \frac{\partial \phi}{\partial R} \right|_{R, 0}$$

R_g : guiding center

The stationary point in R_g in the meridional plane corresponds to a circular orbit

Examples

① Miyamoto - Nagai potential

$$\phi(R, z) = - \frac{GM}{\sqrt{R^2 + (a + \sqrt{z^2 + b^2})^2}}$$

$$\phi_{df}(R, z=0) = - \frac{GM}{\sqrt{R^2 + (a+b)^2}} + \frac{L_z^2}{2R^2}$$

Miyamoto Nagai Potential

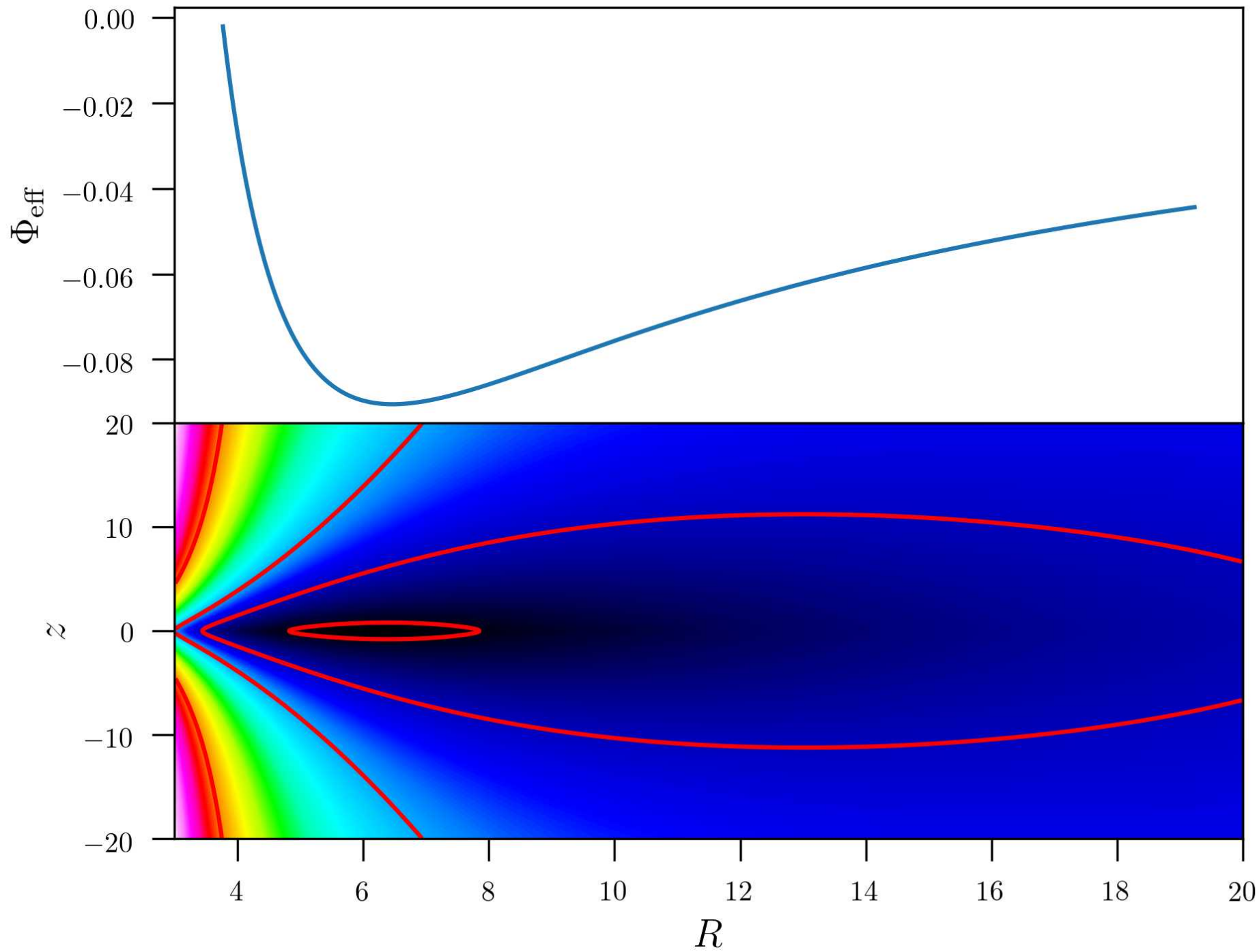

Miyamoto Nagai Potential

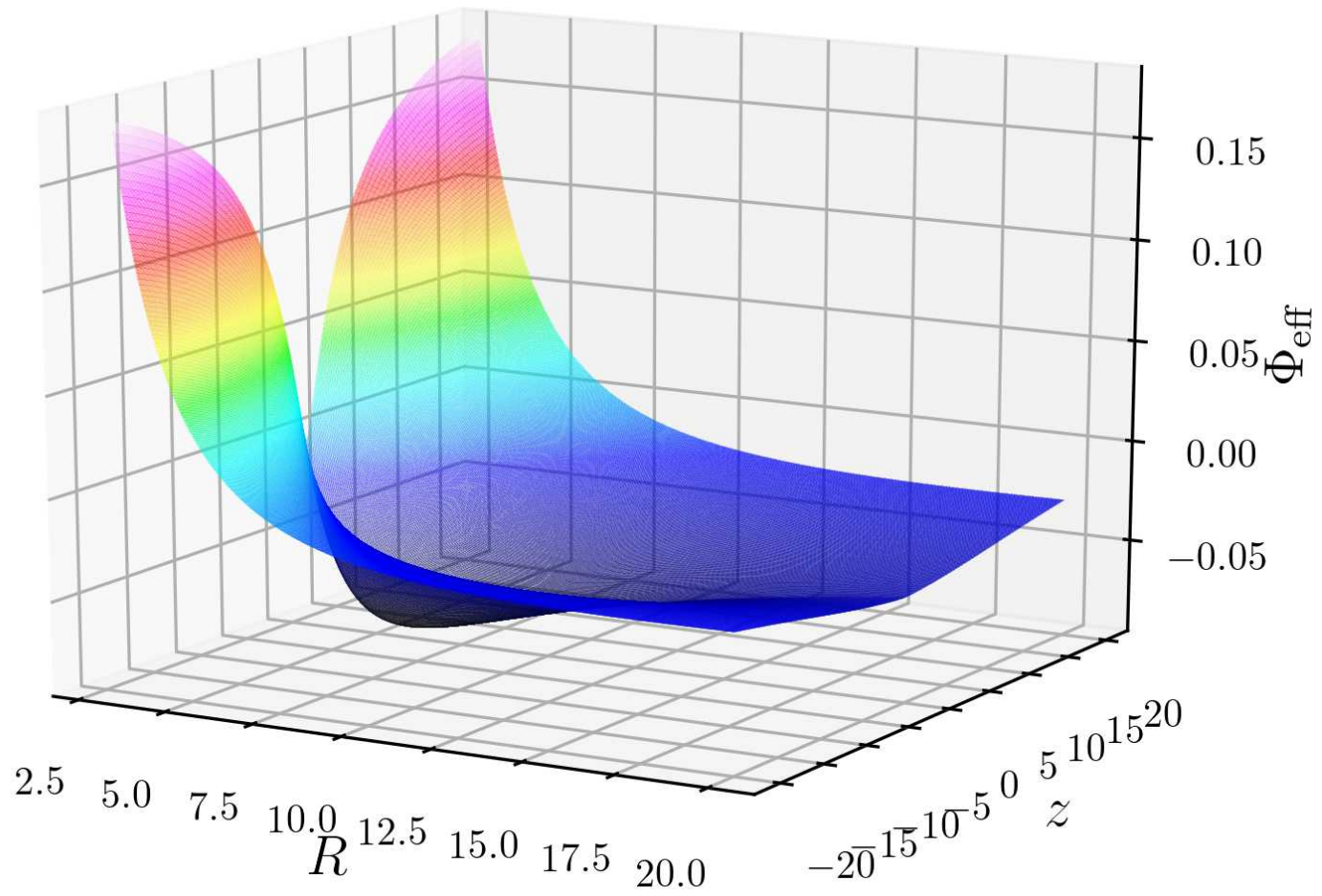

Examples

① Miyamoto - Nagai potential

$$\phi(R, z) = - \frac{GM}{\sqrt{R^2 + (a + \sqrt{z^2 + b^2})^2}}$$

$$\phi_{\text{eff}}(R, z=0) = - \frac{GM}{\sqrt{R^2 + (a+b)^2}} + \frac{L_z^2}{2R^2}$$

② Logarithmic potential

$$\phi(R, z) = \frac{1}{2} V_0^2 \ln \left(R^2 + \frac{z^2}{q^2} \right)$$

$$\phi_{\text{eff}}(R, z=0) = \frac{1}{2} V_0^2 \ln(R^2) + \frac{L_z^2}{2R^2}$$

Logarithmic Potential

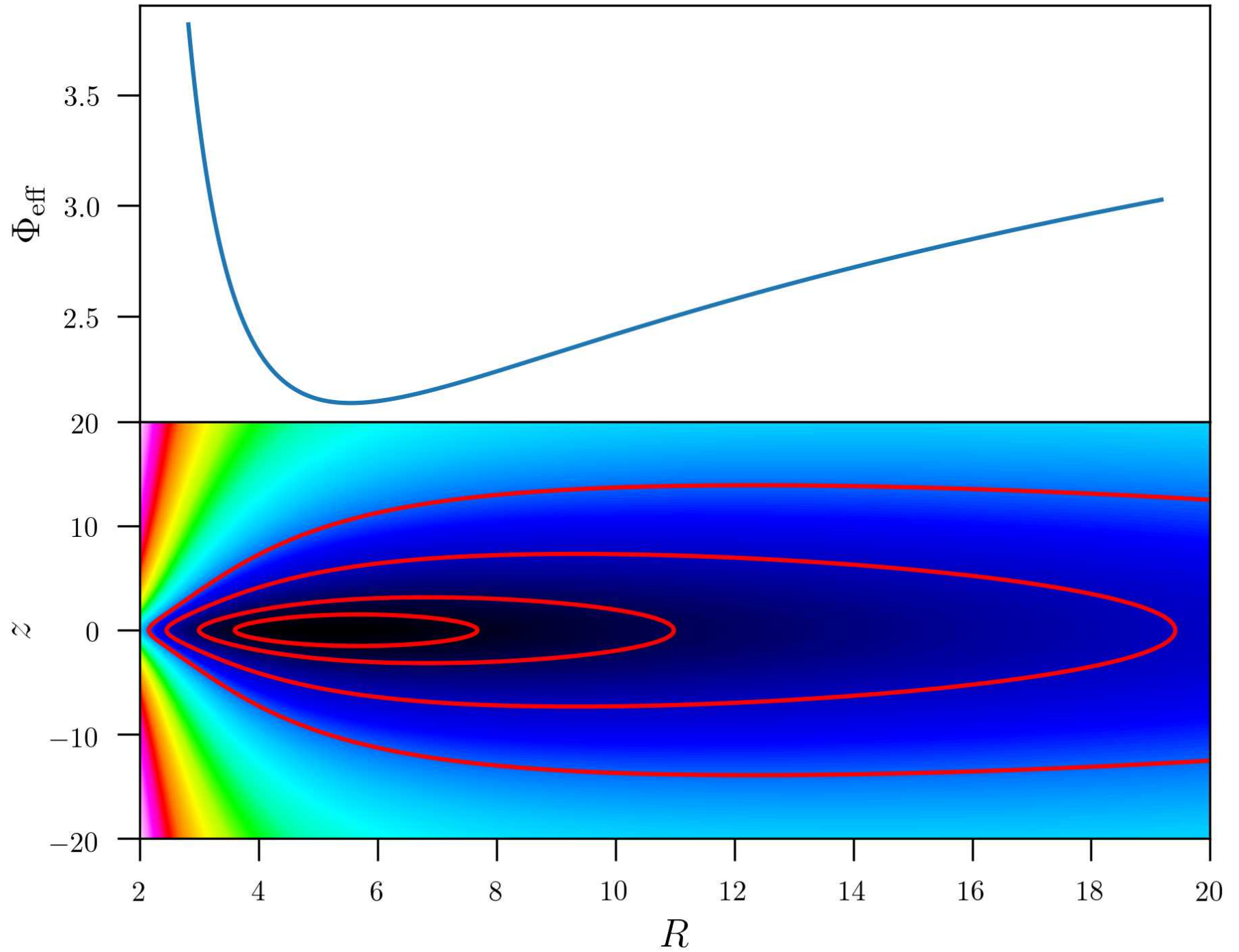

Logarithmic Potential

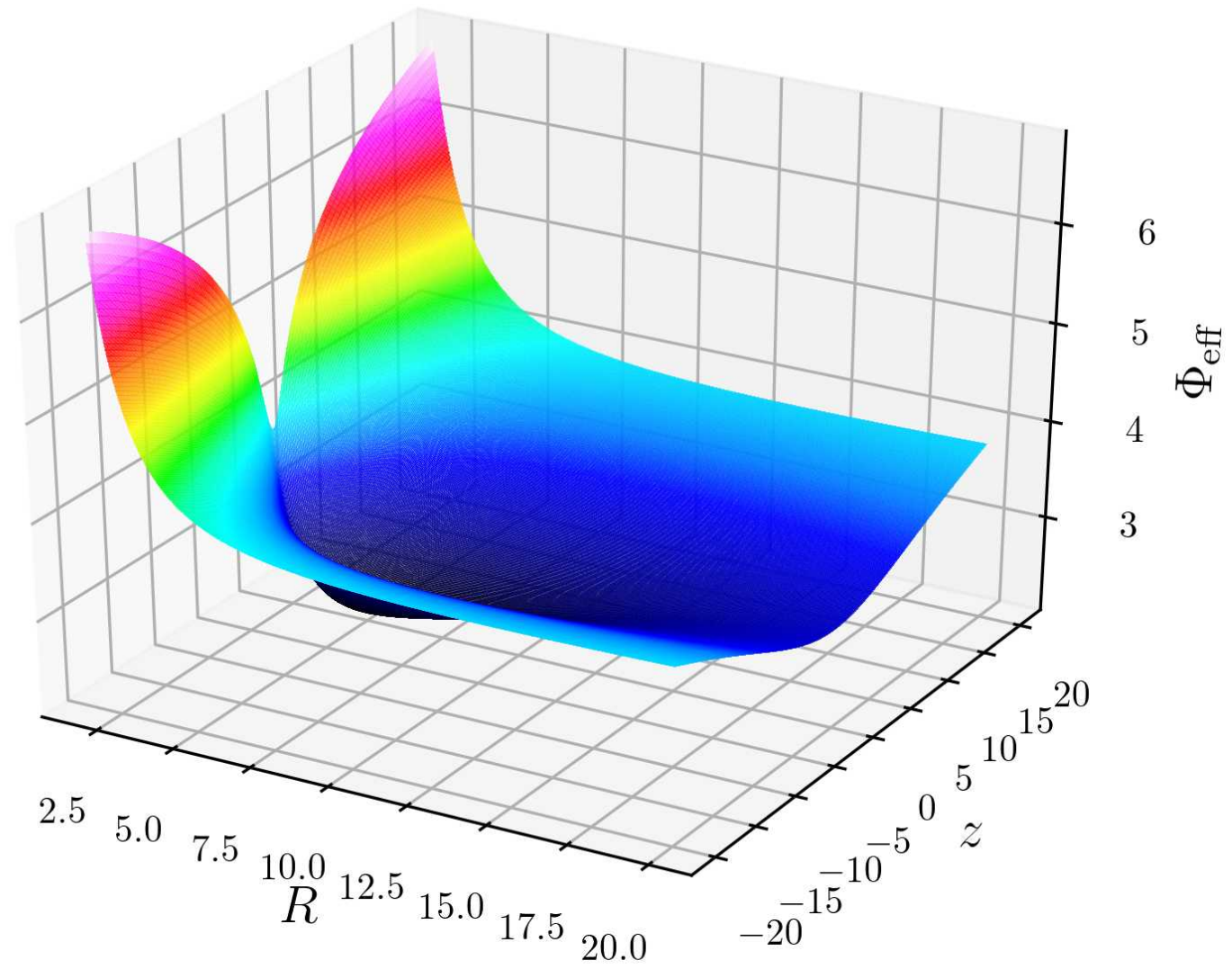

Circular orbits

angular speed $\dot{\theta} = \frac{L_z}{R_g^2}$

angular momentum L_z

energy $\phi_{\text{eff}} + \frac{L_z^2}{2R_g}$

Note

For a given angular momentum L_z , the circular orbit is the one that minimize the energy.

① $E_0 = \frac{1}{2} \dot{R}^2 + \frac{1}{2} \dot{z}^2 + \phi + \frac{L_z^2}{2R}$

② Dissipate energy $L_z = \text{cte}$
 $\dot{z} \rightarrow R \dot{\theta}$

③ circular orbit

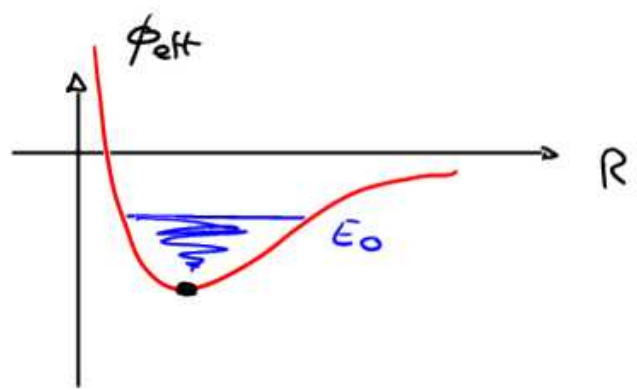

General solutions for the equations of motion

$$\begin{cases} \ddot{R} &= - \frac{\partial \phi_{\text{eff}}}{\partial R}(R, z) \\ \ddot{z} &= - \frac{\partial \phi_{\text{eff}}}{\partial z}(R, z) \end{cases}$$

no simple solutions 😞

need numerical integration

Hamilton's Equations

$$\vec{q} = \begin{cases} R \\ z \end{cases} \quad \dot{\vec{q}} = \begin{cases} \dot{R} \\ \dot{z} \end{cases} \quad \vec{p} = \begin{cases} p_R \\ p_z \end{cases}$$

$$\begin{cases} \dot{q}_R = p_R & \equiv \dot{R} \\ \dot{q}_z = p_z & \equiv \dot{z} \\ \dot{p}_R = - \frac{\partial \phi_{\text{eff}}}{\partial q_R}(q_R, q_z) & \equiv - \frac{\partial \phi_{\text{eff}}}{\partial R}(R, z) \\ \dot{p}_z = - \frac{\partial \phi_{\text{eff}}}{\partial q_z}(q_R, q_z) & \equiv - \frac{\partial \phi_{\text{eff}}}{\partial z}(R, z) \end{cases}$$

Miyamoto — Nagai : $\Delta E = 0.2$

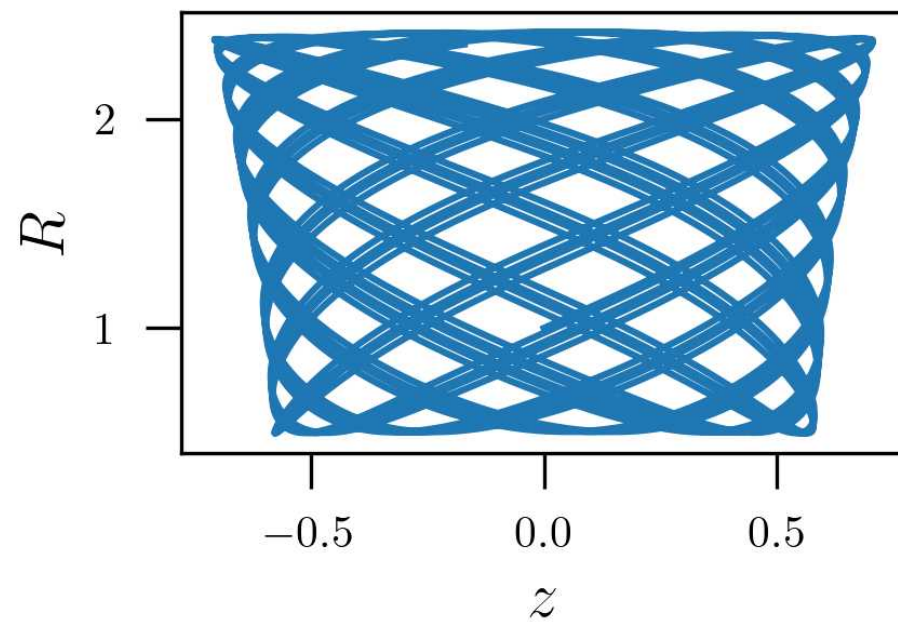
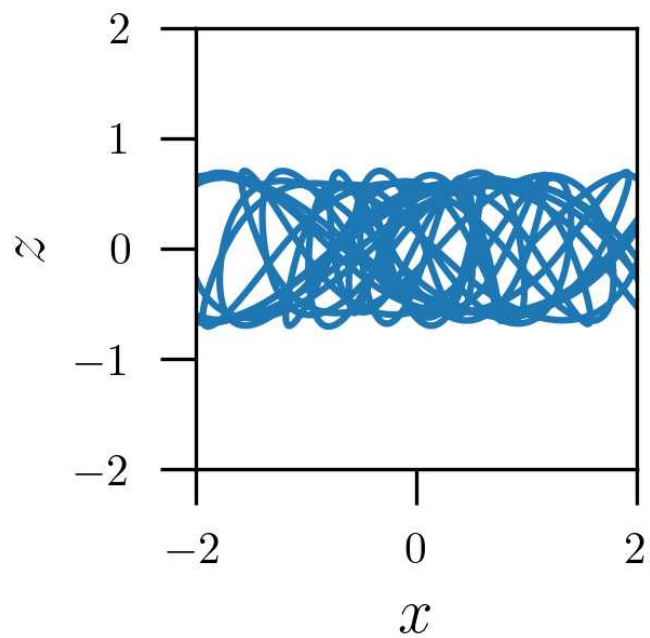
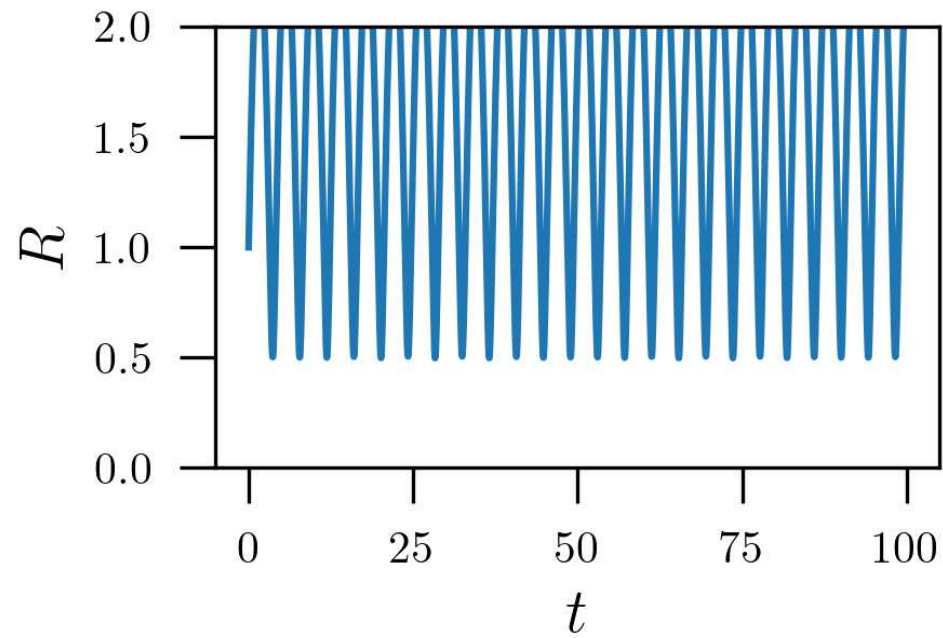
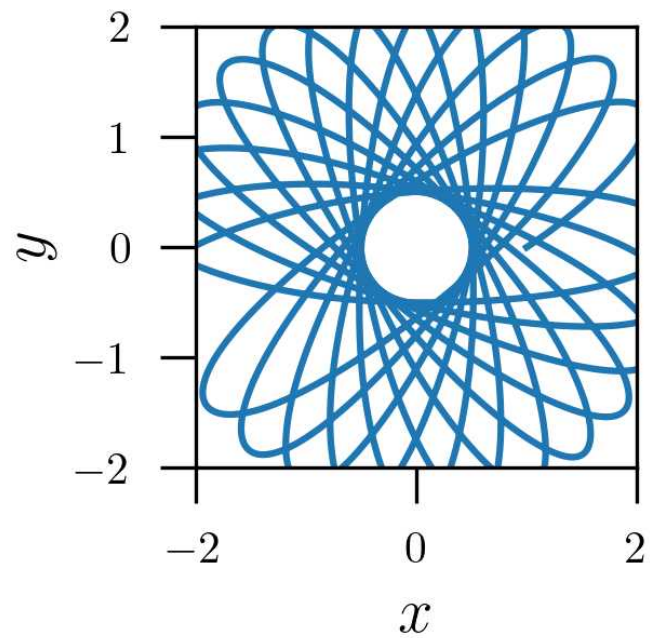

Miyamoto — Nagai : $\Delta E = 0.1$

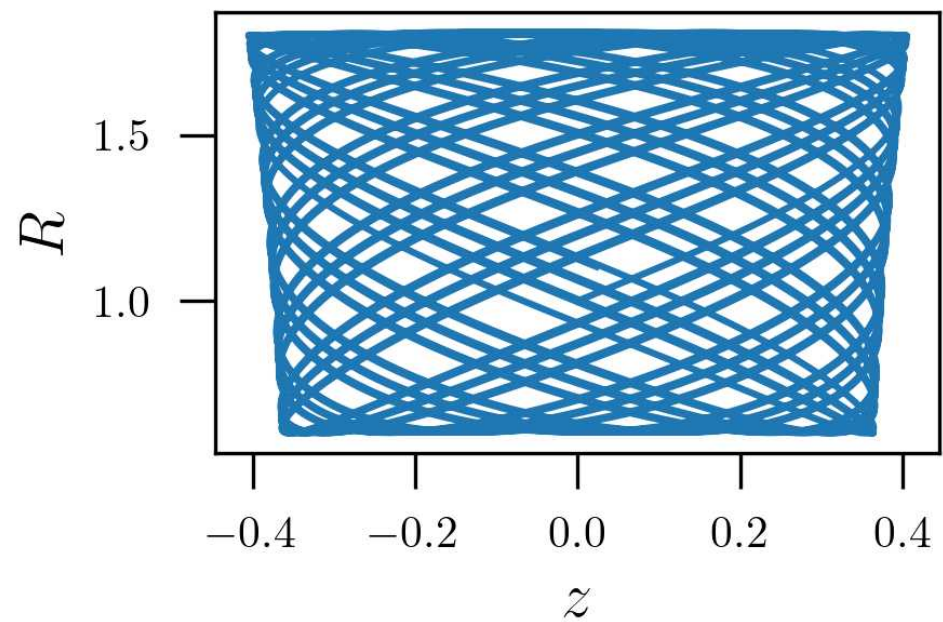
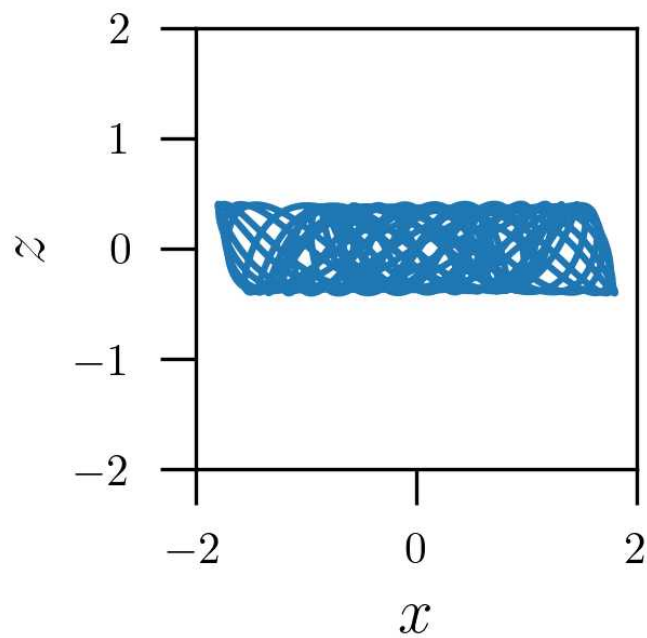
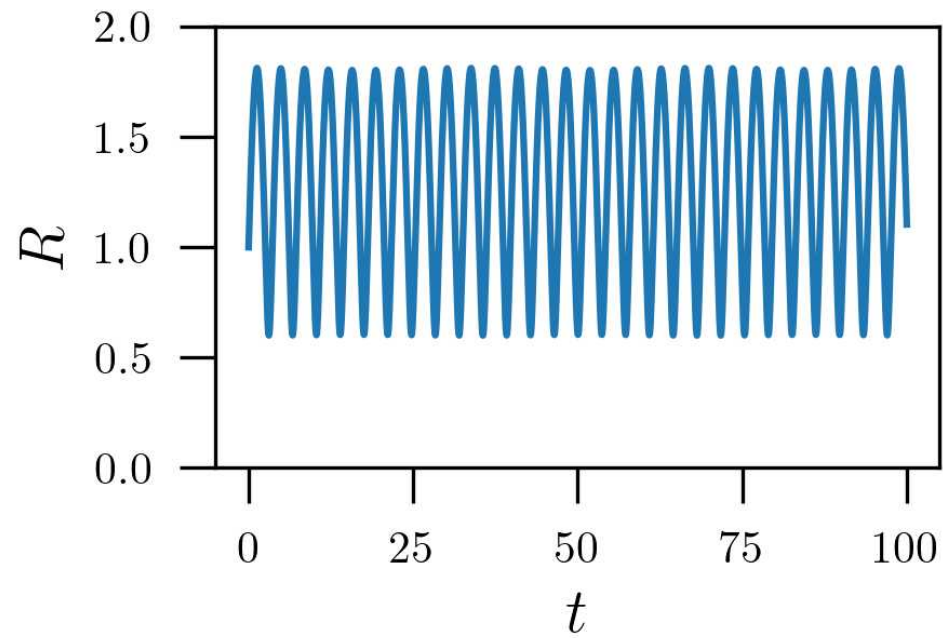
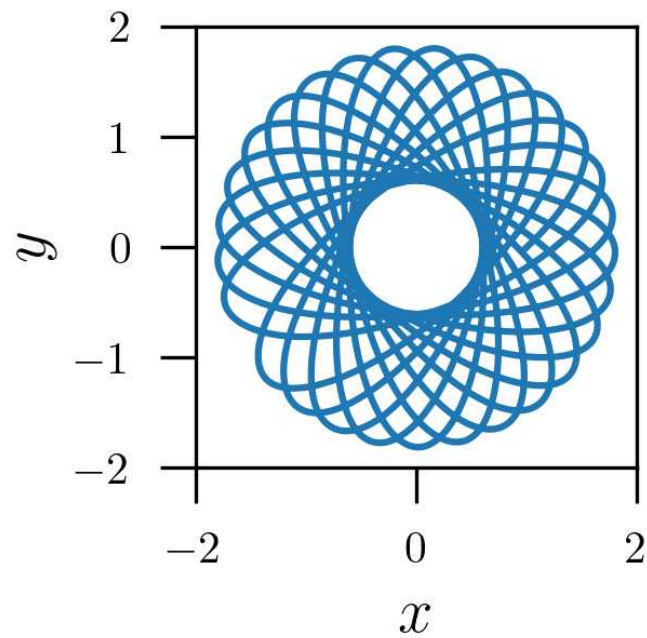

Miyamoto – Nagai : $\Delta E = 0.01$

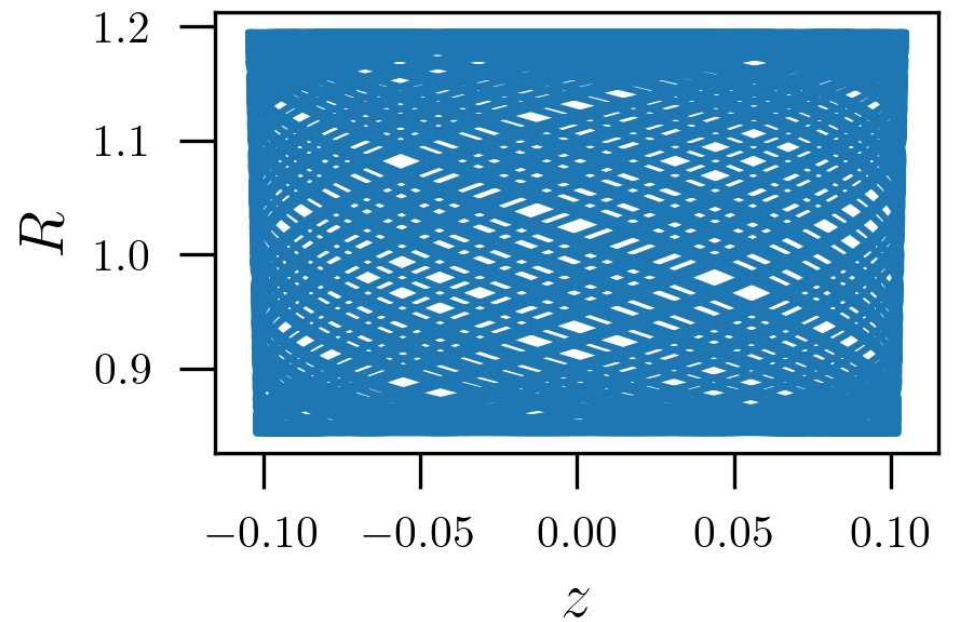
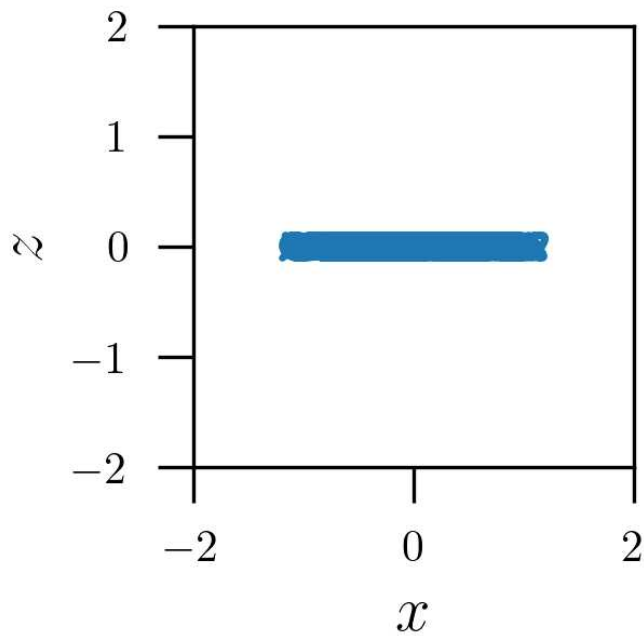
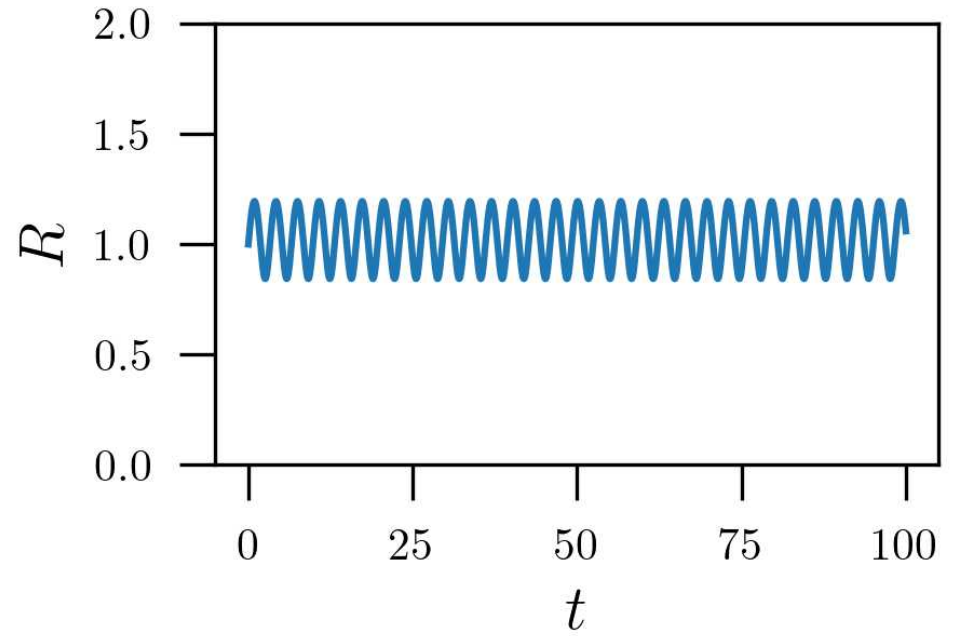
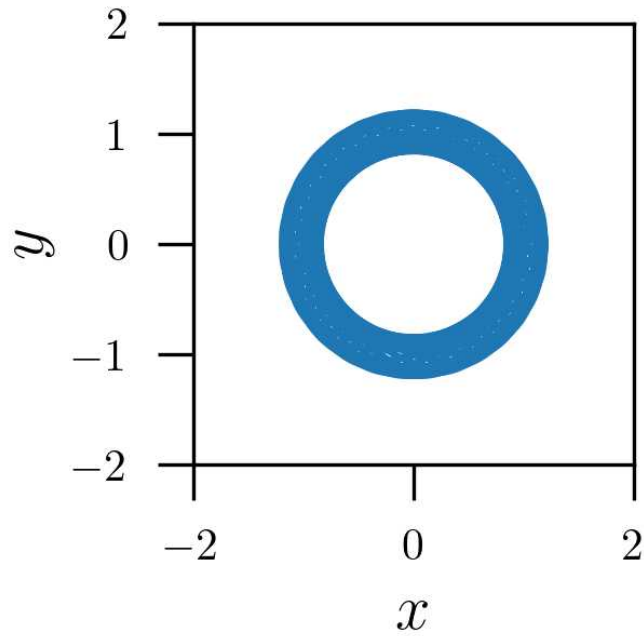

Miyamoto – Nagai : $\Delta E = 0.001$

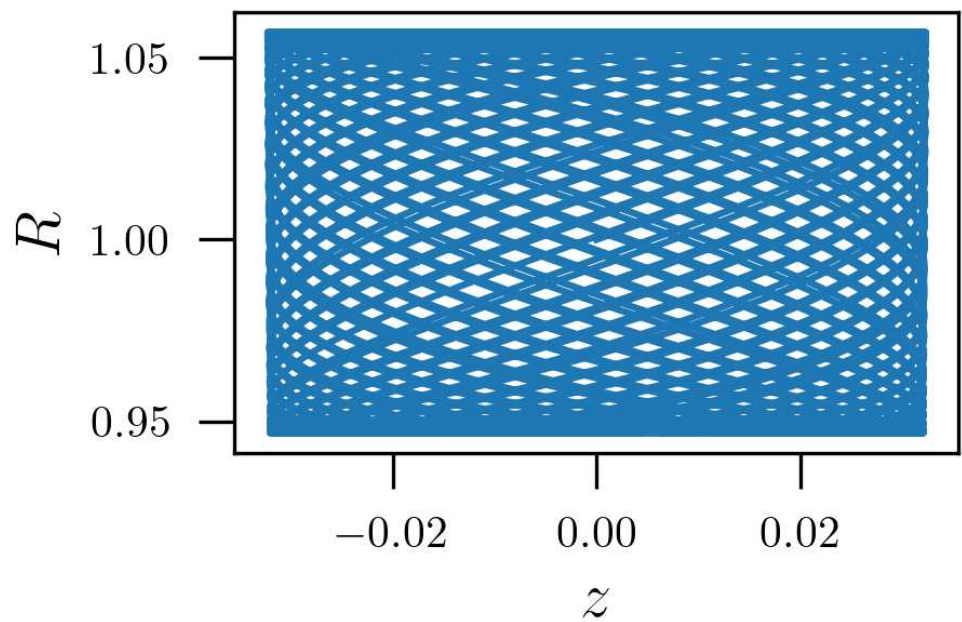
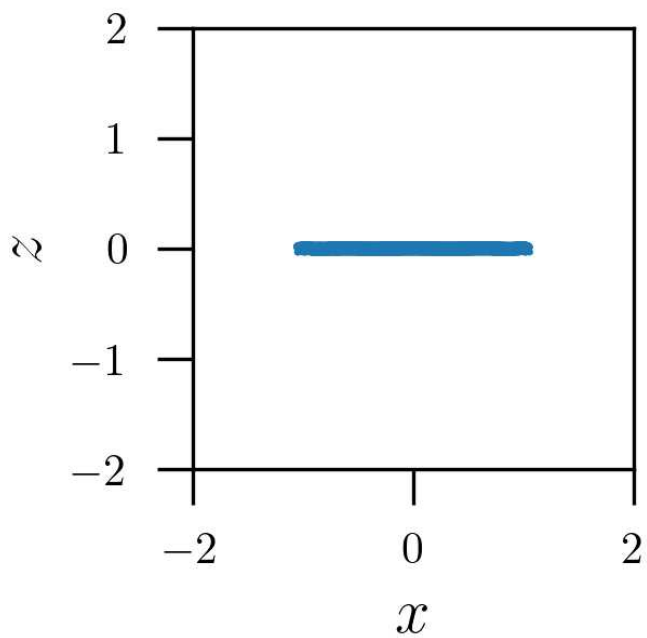
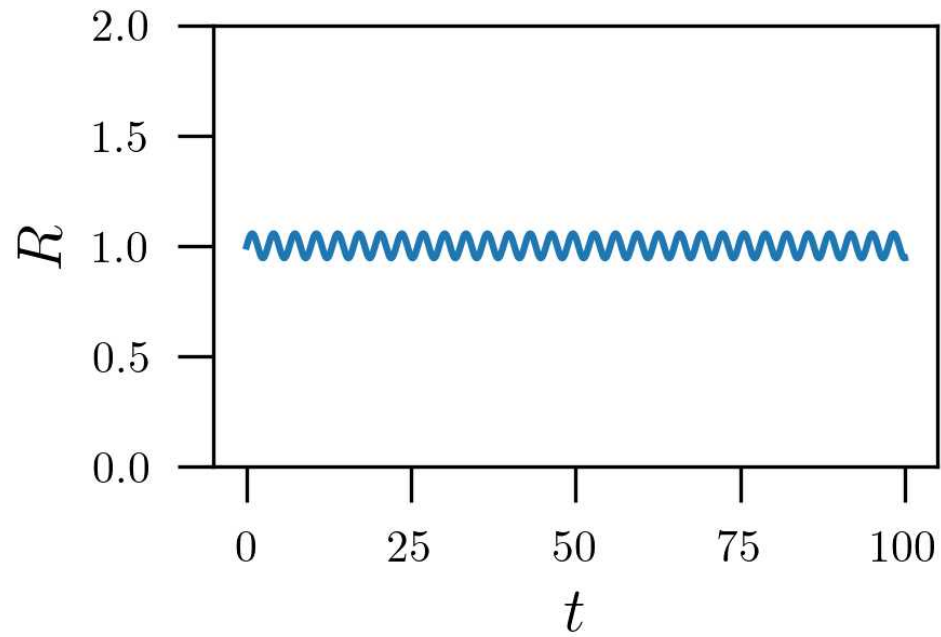
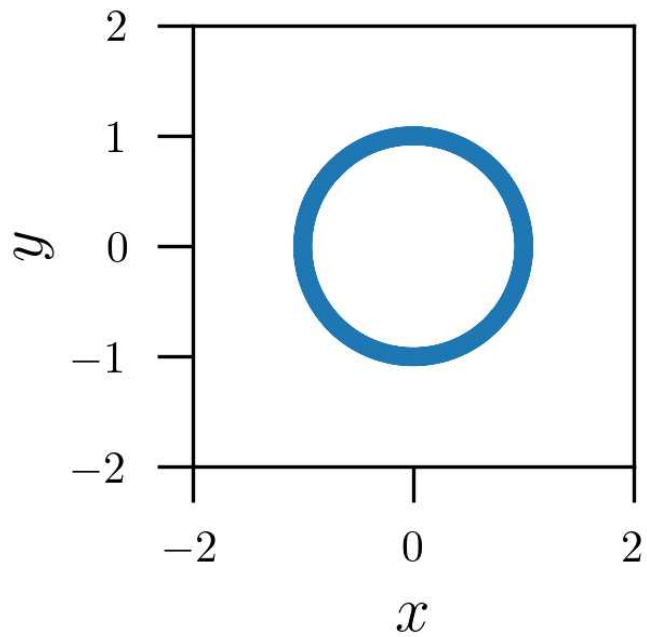

Miyamoto – Nagai : $\Delta E = 0$

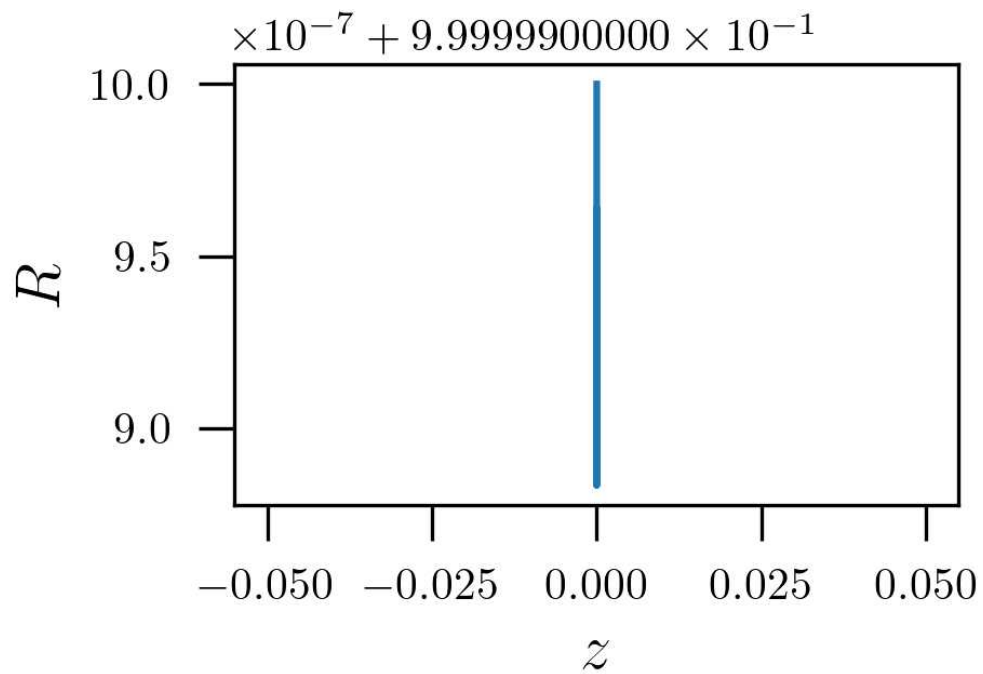
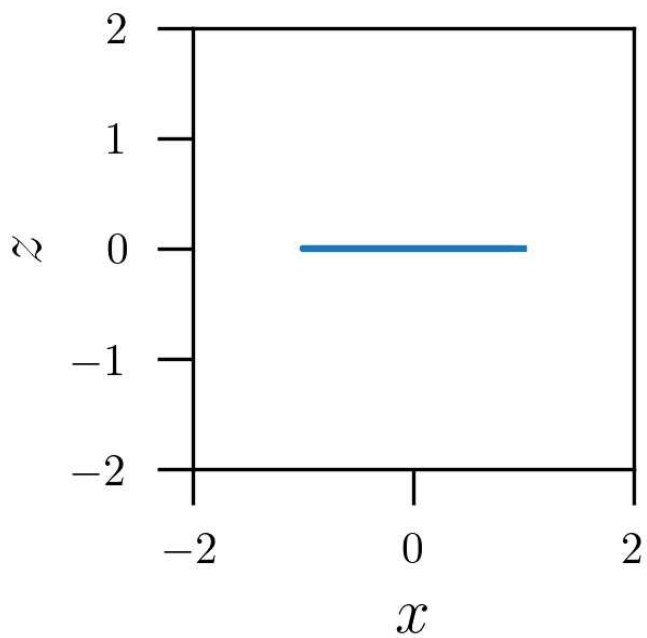
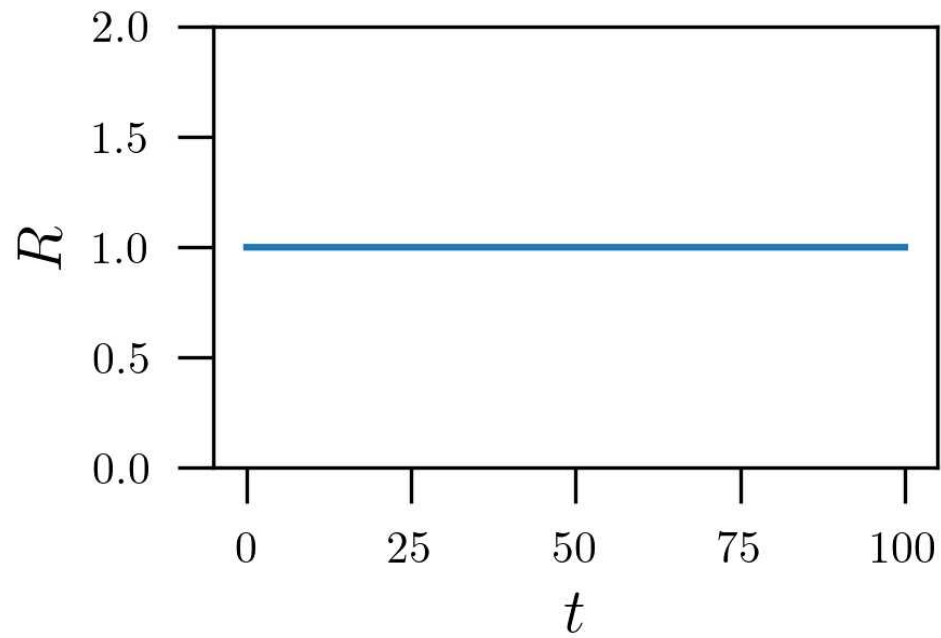
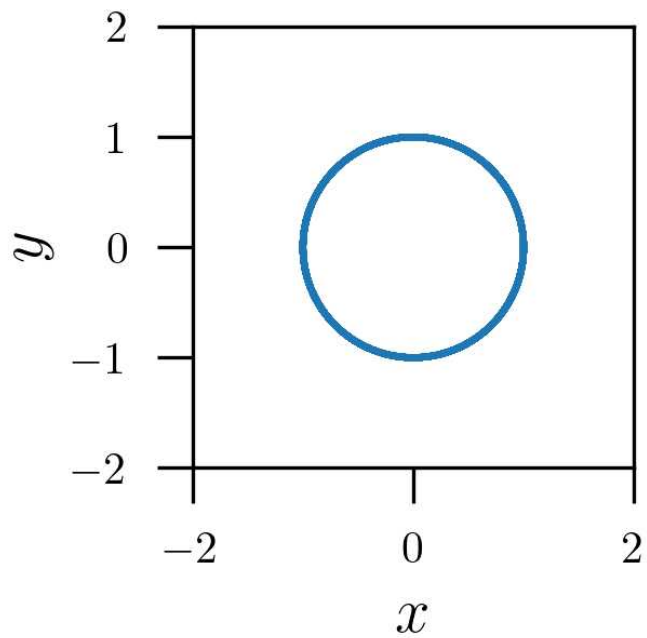

Stellar orbits

Nearly circular orbits

Nearly circular orbits

From the previous study of orbits in axisymmetric potentials

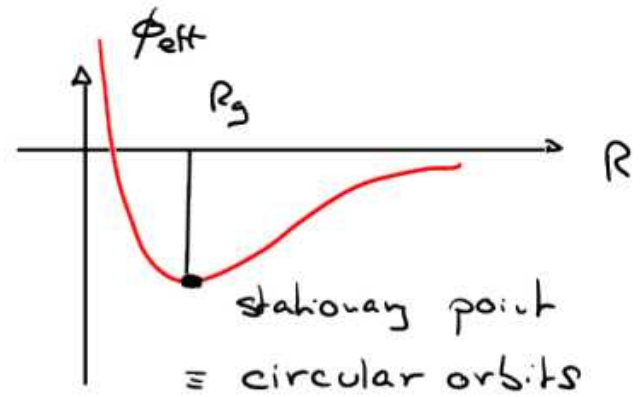

Goal Study orbits in the neighbourhood of circular orbits

Justifications In a disk galaxy, many stars are found in nearly circular orbits

Recall R_g : the guiding center

$$R_g \text{ such that } \left. \frac{\partial \phi}{\partial R} \right|_{R_g, 0} = \frac{L_z^2}{R_g^3} = R_g \dot{\theta}^2$$

We define

$$x := R - R_g$$

the distance to the guiding center R_g

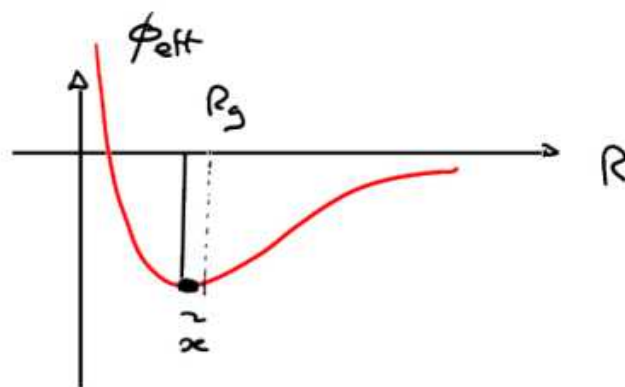
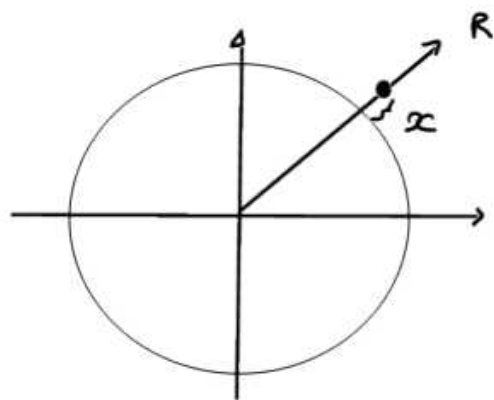

Taylor expansion of ϕ_{eff} around $R = R_g$, $z = 0$

$$\begin{aligned} \phi_{\text{eff}}(R, z) &\approx \phi_{\text{eff}}(R_g, 0) + \underbrace{\frac{\partial \phi_{\text{eff}}}{\partial R}(R_g, 0)}_{=0 \text{ min}} (R - R_g) + \underbrace{\frac{\partial \phi_{\text{eff}}}{\partial z}(R_g, 0)}_{=0 \text{ sym.}} z \\ &+ \frac{1}{2} \frac{\partial^2 \phi_{\text{eff}}}{\partial R^2}(R_g, 0) (R - R_g)^2 + \frac{1}{2} \frac{\partial^2 \phi_{\text{eff}}}{\partial z^2}(R_g, 0) z^2 \\ &+ \frac{1}{2} \frac{\partial^2 \phi_{\text{eff}}}{\partial z \partial R}(R_g, 0) (R - R_g) z + \mathcal{O}(((R - R_g)z)^3) \\ &= 0 \quad \phi_{\text{eff}}(R, z) \text{ must be sym. with respect to } z = 0 \end{aligned}$$

$$\phi_{\text{eff}}(R, z) \approx \phi_{\text{eff}}(R_g, 0) + \frac{1}{2} \frac{\partial^2 \phi_{\text{eff}}}{\partial R^2}(R_g, 0) x^2 + \frac{1}{2} \frac{\partial^2 \phi_{\text{eff}}}{\partial z^2}(R_g, 0) z^2$$

Definition

$$\left\{ \begin{array}{l} \omega^2(R_g) = \left(\frac{\partial^2 \phi_{\text{eff}}}{\partial R^2} \right)_{(R_g, 0)} \\ \nu^2(R_g) = \left(\frac{\partial^2 \phi_{\text{eff}}}{\partial z^2} \right)_{(R_g, 0)} \end{array} \right.$$

$$[\phi] = \left(\frac{m}{s} \right)^2$$

$$\left[\left(\frac{\partial^2 \phi}{\partial R^2} \right)^{\frac{1}{2}} \right] = \left[\left(\frac{\partial^2 \phi}{\partial z^2} \right)^{\frac{1}{2}} \right] = \frac{1}{s}$$

frequency

Equations of motion near R_g

$$\left\{ \begin{array}{l} \ddot{R} = - \frac{\partial \phi_{\text{eff}}}{\partial R}(R, z) \\ \ddot{z} = - \frac{\partial \phi_{\text{eff}}}{\partial z}(R, z) \end{array} \right. \Rightarrow$$

$$\left\{ \begin{array}{l} \ddot{x} = - \omega^2(R_g) x \\ \ddot{z} = - \nu^2(R_g) z \end{array} \right.$$

$$\begin{cases} \ddot{x} = -\omega^2(R_g) x \\ \ddot{z} = -\nu^2(R_g) z \end{cases}$$

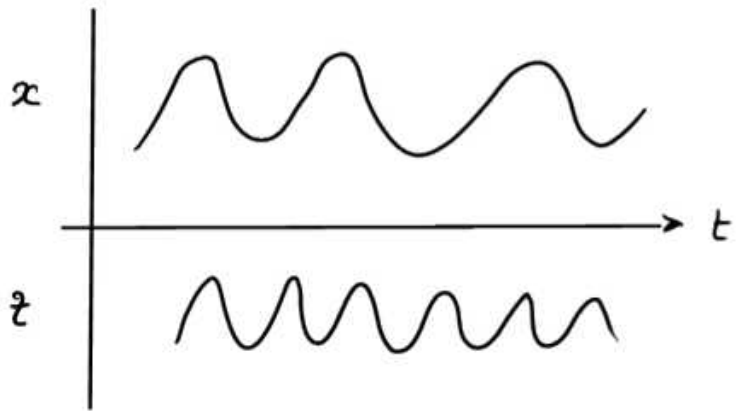

Two decoupled harmonic oscillators
with frequencies ω and ν

ω : epicycle (radial) frequency

ν : vertical frequency

Expressions of ω and ν from the total potential

$$\begin{aligned}
 \omega^2(R_g) &= \frac{\partial^2 \phi_{\text{eff}}}{\partial R^2} \Big|_{(R_g, 0)} = \frac{\partial^2 \phi}{\partial R^2} \Big|_{(R_g, 0)} + 3 \frac{L_z^2}{R_g^4} \\
 &= \frac{\partial^2 \phi}{\partial R^2} \Big|_{(R_g, 0)} + \frac{3}{R_g} \frac{\partial \phi}{\partial R} \Big|_{(R_g, 0)} \\
 &= \frac{\partial^2 \phi}{\partial R^2} \Big|_{(R_g, 0)} + 3 \Omega^2 \\
 &= \left(R \frac{\partial (\Omega^2)}{\partial R} + 4 \Omega^2 \right) \Big|_{(R_g, 0)} \\
 &= \left(\frac{1}{R} \frac{\partial (V_c^2)}{\partial R} + 2 \Omega^2 \right) \Big|_{(R_g, 0)} = \left(\frac{1}{R} \frac{\partial (V_c^2)}{\partial R} + 2 \frac{V_c^2}{R^2} \right) \Big|_{(R_g, 0)}
 \end{aligned}$$

circ. frequency $\Omega^2 = \frac{1}{R_g} \frac{\partial \phi}{\partial R} \Big|_{R_g}$ \downarrow
 $\Omega^2 = \frac{V_c^2}{R^2}$ \downarrow

$L_z^2 = V_c^2 R_g^2$
 $= R_g^3 \frac{\partial \phi}{\partial R} \Big|_{R_g}$

$$\nu^2(R_g) = \frac{\partial^2 \phi_{\text{eff}}}{\partial z^2} \Big|_{(R_g, 0)} = \frac{\partial^2 \phi}{\partial z^2} \Big|_{(R_g, 0)}$$

Note : α depends only on V_c

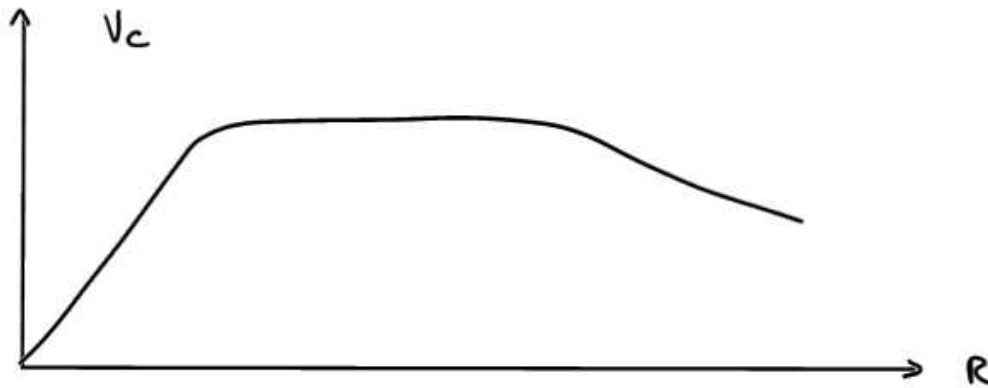

α obtained by
derivating V_c^2

Periods :

{ radial
vertical
azimuthal

$$T_R := \frac{2\pi}{\alpha}$$

$$T_z := \frac{2\pi}{\gamma}$$

$$T_\theta := \frac{2\pi}{\Omega}$$

Radial dependency of κ , ν for a typical galaxy

$$\Omega = \frac{V_c}{R}$$

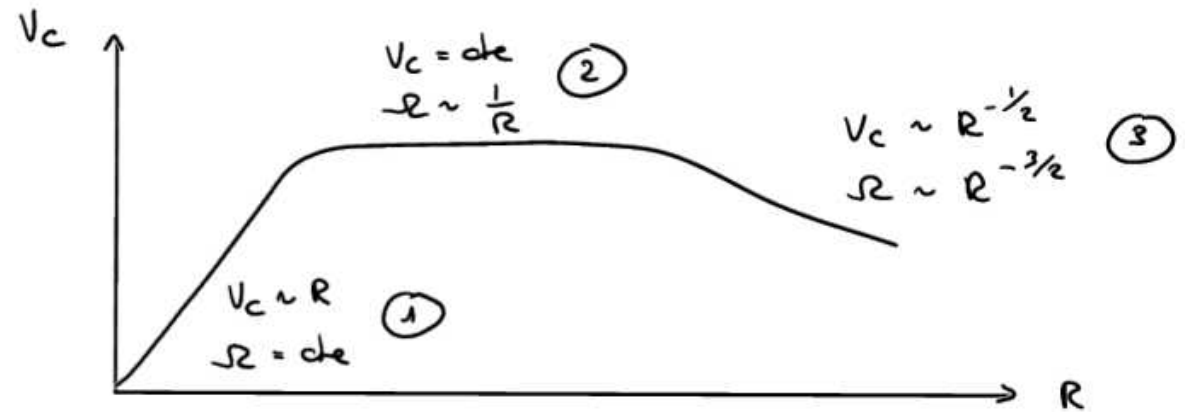

- (1) near the center

$$V_c \sim R \quad (\text{rigid rotation})$$

$$\Rightarrow \Omega = \text{cte}$$

$$\kappa^2 = R \frac{d}{dR}(\Omega^2) + 4\Omega^2$$

$$\Rightarrow \kappa^2 = 4\Omega^2$$

$$\kappa \sim 2\Omega$$

Radial dependency of κ , ν for a typical galaxy

$$\Omega = \frac{V_c}{R}$$

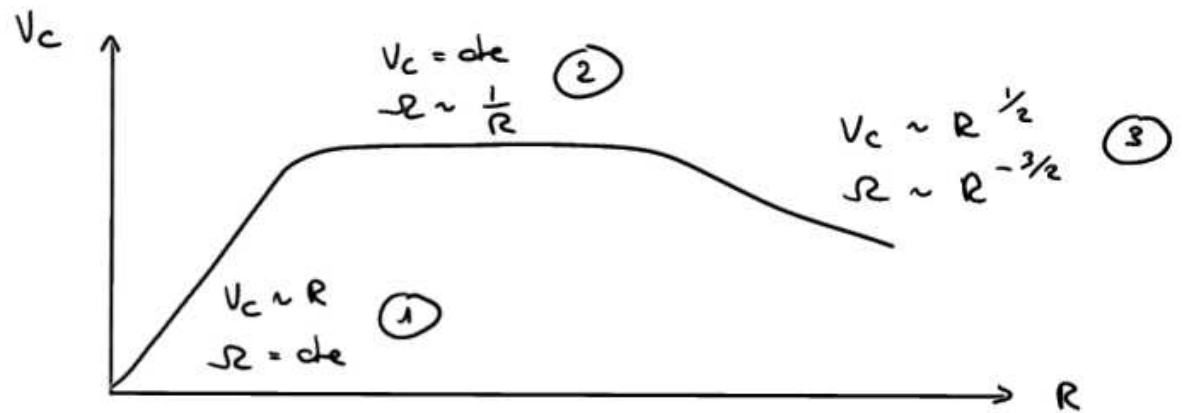

• (2) flat rotation part

$$V_c = \text{cte}$$

$$\Omega \sim \frac{1}{R}$$

$$\kappa^2 = \frac{1}{R} \frac{\partial}{\partial R} (V_c^2) + 2\Omega^2$$

$$\Rightarrow \kappa^2 = 2\Omega^2$$

$$\kappa \sim \sqrt{2} \Omega$$

Radial dependency of κ , ν for a typical galaxy

$$\Omega = \frac{V_c}{R}$$

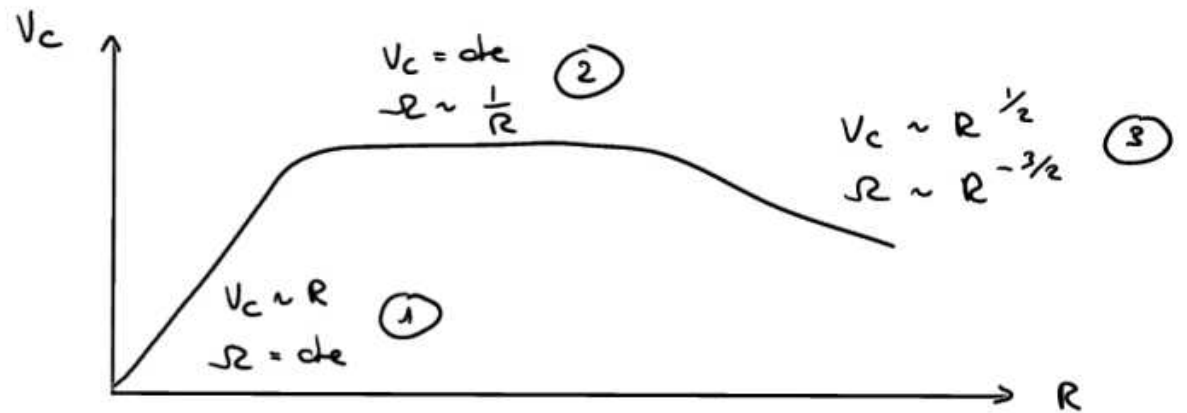

• ③ further out

$$V_c \sim R^{-1/2} \text{ (Keplerian decrease)}$$

$$\Omega = \frac{V_c}{R} \sim R^{-3/2}$$

$$\kappa^2 = \frac{1}{R} \frac{\partial}{\partial R} (V_c^2) + 2 \frac{V_c^2}{R^2} \sim R^{-3}$$

$$\kappa = \Omega$$

Thus, in general

$$\Omega \leq \mathcal{L} \leq 2\Omega$$

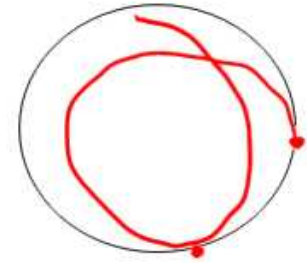

Integrals of motions

$$\begin{cases} \ddot{x} = -\omega^2(R_g) x \\ \ddot{z} = -\nu^2(R_g) z \end{cases}$$

\Rightarrow Two integrals of motion
(one for each oscillator)

$$1) H_R = \frac{1}{2} \dot{x}^2 + \frac{1}{2} \omega^2 x^2$$

$$2) H_z = \frac{1}{2} \dot{z}^2 + \frac{1}{2} \nu^2 z^2$$

Thus, if a star oscillates near a circular orbit :

3 integrals of motions

L_z, H_R, H_z

Total Hamiltonian (near a circular orbit of radius R_s)

$$H(R, \dot{R}, \theta, \dot{\theta}, z, \dot{z}) = \frac{1}{2} (\dot{R}^2 + R^2 \dot{\theta}^2 + \dot{z}^2) + \phi(R, z)$$

$$= \frac{1}{2} \dot{R}^2 + \frac{1}{2} \dot{z}^2 + \underbrace{\phi(R, z)}_{\phi_{\text{eff}}(R, z)} + \frac{L_z^2}{2R^2}$$

$$L_z = R^2 \dot{\theta}$$

$$= \frac{1}{2} \dot{R}^2 + \frac{1}{2} \dot{z}^2 + \phi_{\text{eff}}(R_s, 0) + \frac{1}{2} \kappa^2 (R - R_s)^2 + \frac{1}{2} \nu^2 z^2$$

$$H(R, p_R, z, p_z) = H_R(R, p_R) + H_z(z, p_z) + \phi_{\text{eff}}(R_s, 0)$$

Orbital motions

$$\begin{cases} \ddot{x} = -\kappa^2(R_g) x \\ \ddot{z} = -\nu^2(R_g) z \end{cases}$$

$$+ R^2 \dot{\theta} = L_z$$

Solutions

① motion in z

$$z(t) = \tilde{z} \cos(\nu t + \xi)$$

② motion in x

$$x(t) = X \cos(\kappa t + \alpha)$$

Note valid only for small oscillations

as long as $\nu^2 = \frac{\partial^2 \phi}{\partial z^2} \approx \text{cte}$

ie $\rho_{\text{disk}} \approx \text{cte}$ ($\nu^2 = \frac{\partial^2 \phi}{\partial z^2} = 4\pi G \rho$)

$\rightarrow z < \text{disk scale length}$

$\sim 300 \text{ pc}$

③ motion in Θ

$$L_z = R^2 \dot{\Theta}$$

$$\begin{aligned}\Theta(t) &= L_z \int_{t_0}^t dt' \frac{1}{R^2(t')} = L_z \int_{t_0}^t dt' \frac{1}{(R_g + x(t'))^2} \\ &\approx \frac{L_z}{R_g^2} \int_{t_0}^t dt' \frac{1}{\left(\frac{x}{R_g} + 1\right)^2} \stackrel{\text{Taylor}}{\approx} R_g \int_{t_0}^t dt' \left(1 - \frac{2x(t')}{R_g}\right)\end{aligned}$$

$R_g = \frac{L_z}{R_g^2}$

introducing $x(t) = X \cos(\omega t + \alpha)$

$$\Theta(t) = \underbrace{R_g \cdot t}_{\text{motion of the guiding center along the circular orbit}} - \underbrace{\frac{2 R_g X}{\omega R_g} \sin(\omega t + \alpha)}_{\text{oscillations}} + \Theta_0$$

motion of the
guiding center
along the circular
orbit

oscillations

New cartesian system

x, y, z

with an origin that follows the guiding center

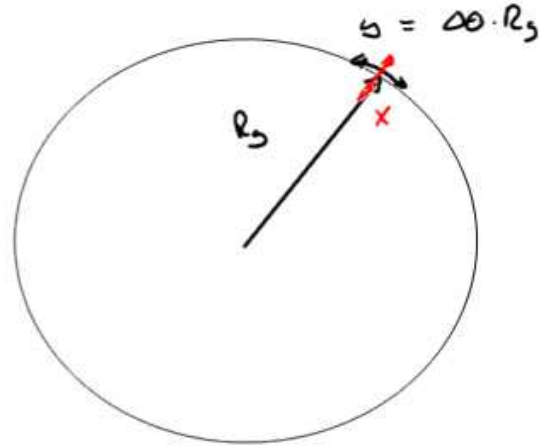

$$\begin{cases} R(t) = R_g \\ \Theta(t) = \Omega_g t + \Theta_0 \end{cases}$$

Then, from

$$\alpha(t) = \Omega_g \cdot t - \frac{2\Omega_g X}{\omega R_g} \sin(\omega t + d) + \Theta_0$$

$$\Delta\theta = \frac{y}{R_g}$$

$$y = -\frac{2\Omega_g}{\omega} X \sin(\omega t + d)$$

$$y(t) = -Y \sin(\omega t + d)$$

$$Y := \frac{2\Omega_g}{\omega} X$$

Complete solution

$$\begin{cases} x(t) = X \cos(\omega t + \alpha) \\ y(t) = -Y \sin(\omega t + \alpha) \\ z(t) = Z \cos(\nu t + \xi) \end{cases}$$

} ellipse

$$Y = \frac{2R_g}{\omega} X$$

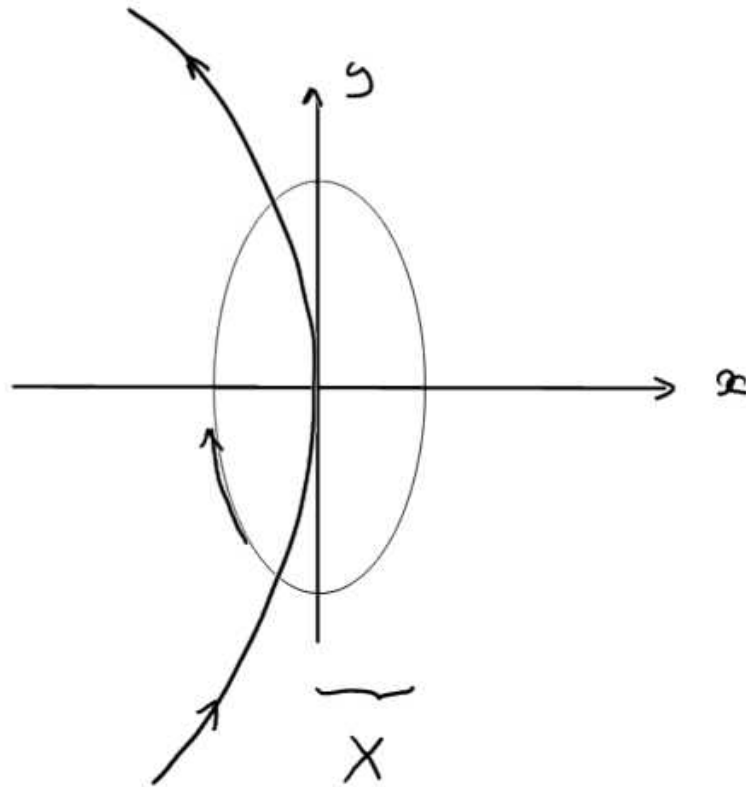

} y

Radial dependence for a typical galaxy

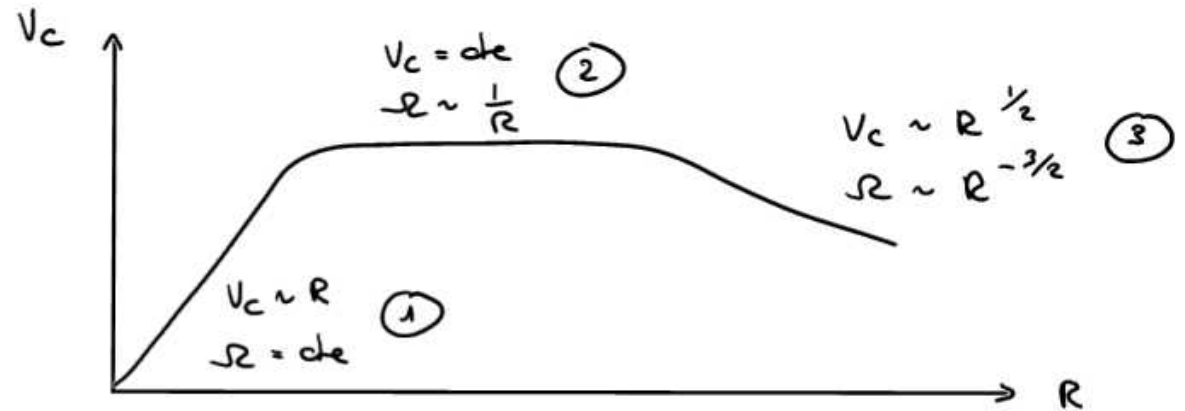

① <u>near the center</u>	$\mathcal{R} = 2\Omega$	$\frac{X}{Y} = 1$	circle	○
② <u>flat rotation part</u>	$\mathcal{R} = \sqrt{2}\Omega$	$\frac{X}{Y} = \frac{\sqrt{2}\Omega}{2\Omega}$	$X < Y$	○
③ <u>further out</u>	$\mathcal{R} = \Omega$	$\frac{X}{Y} = \frac{\Omega}{2\Omega}$	$X < Y$	○

$$\kappa/\Omega = 2.0$$

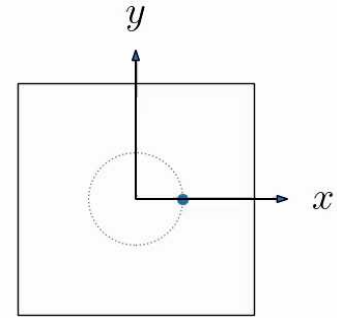
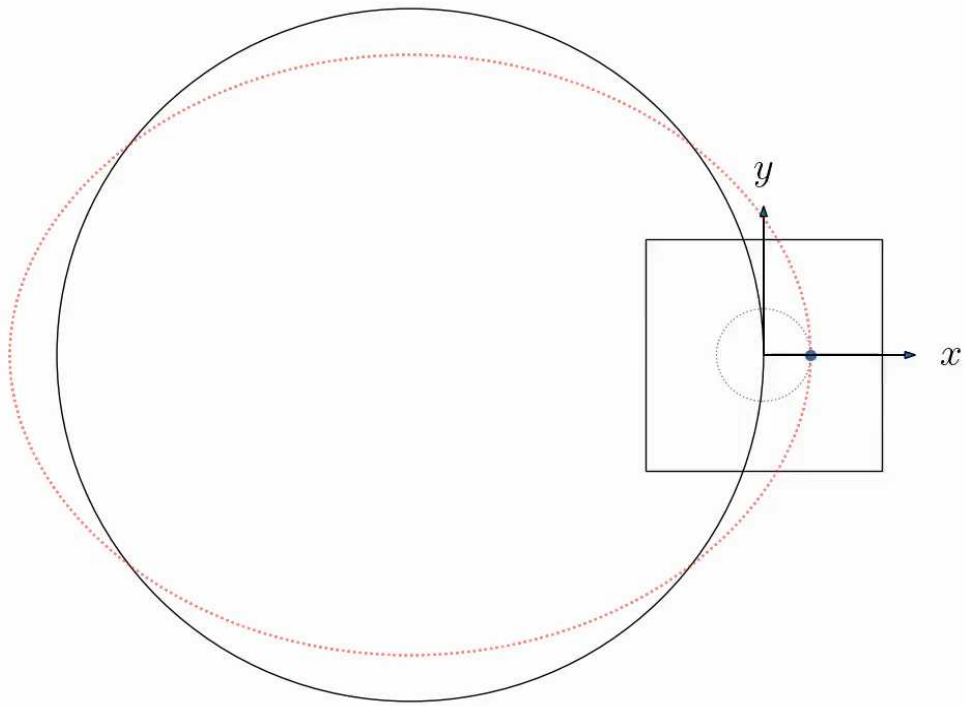

$$\kappa/\Omega = 1.5$$

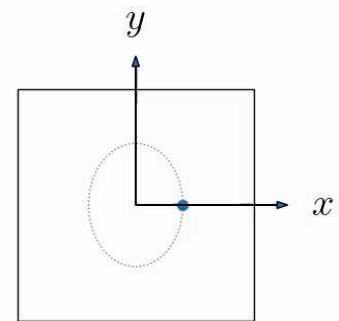
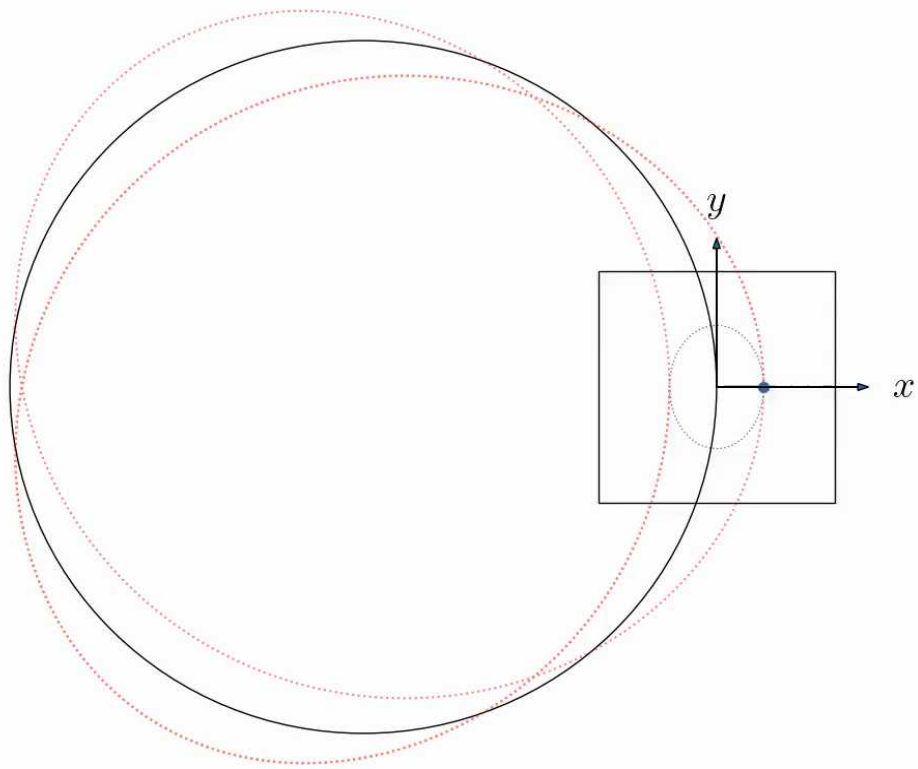

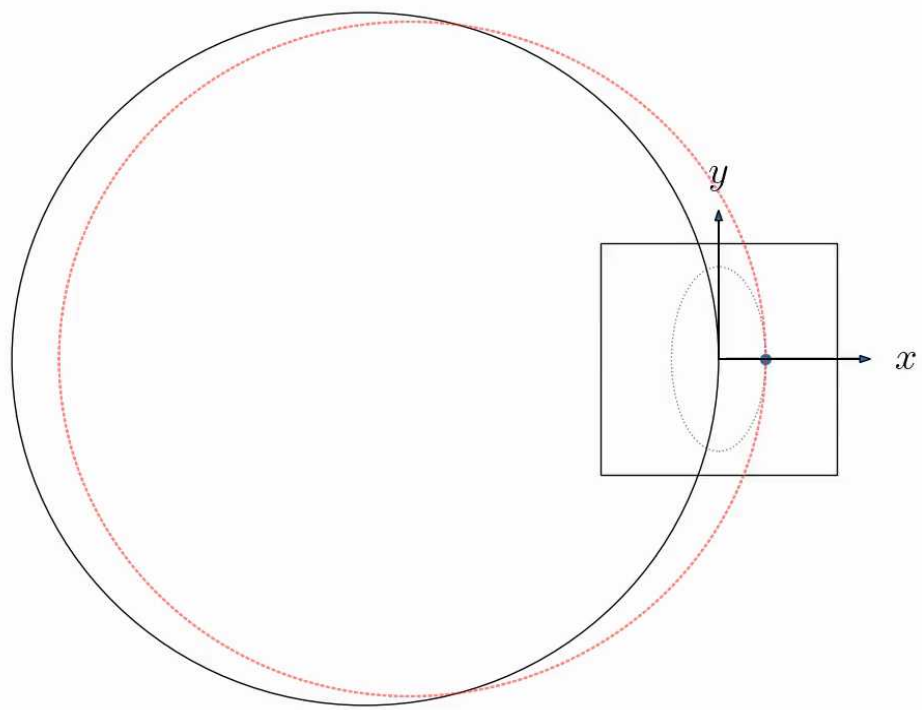

$$\kappa/\Omega = 1.0$$

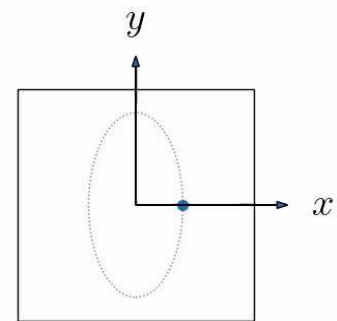

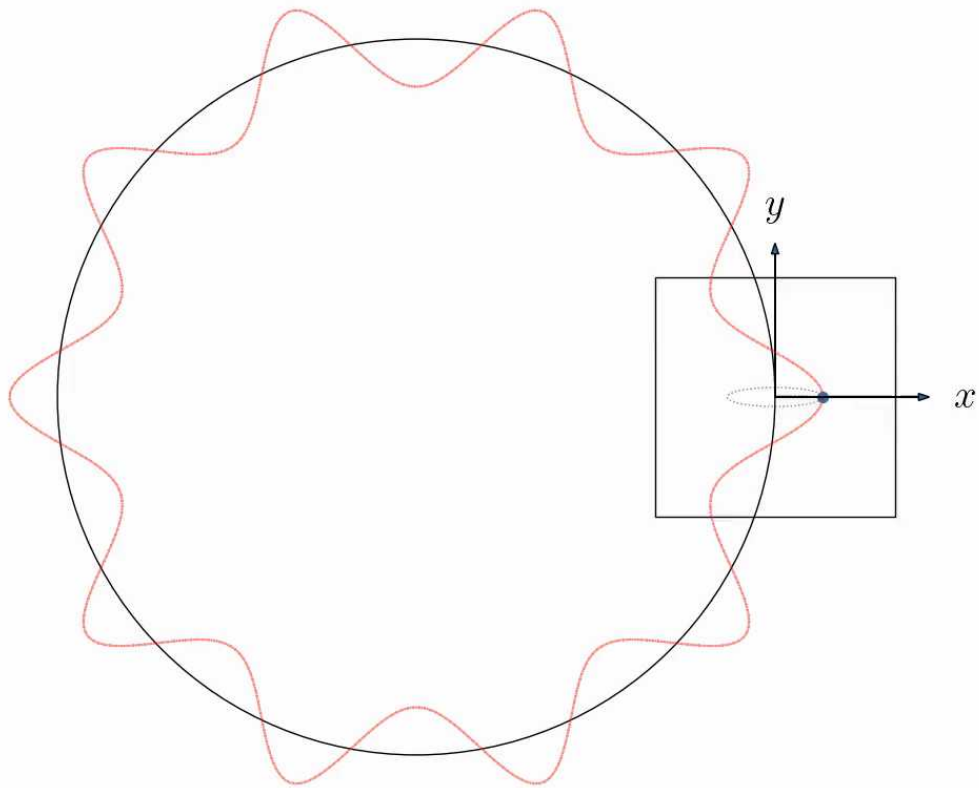

$$\kappa/\Omega = 10.0$$

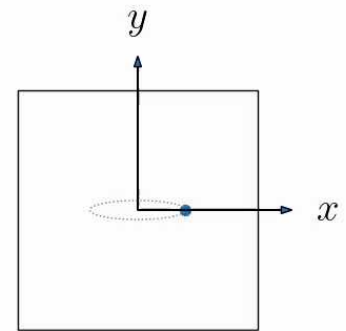

The End