

VHDL

Summary of basic structures

René Beuchat
rene.beuchat@epfl.ch
rene.beuchat@hesge.ch

Resume

- Lexical elements
 - Reserved words
- Declarations
 - Type declaration
 - Subtype declaration
 - Constant declaration
 - Signal declaration
 - Variable declaration

Resume (suite)

- **Concurrent statements**
 - Signal assignment
 - Process statement
 - When statement
 - With statement
- **Sequential statements**
 - Variable assignment
 - If statement
 - Case statement
 - Loop statement

Resume (suite)

- Operators
 - Logic operators
 - Arithmetic operators
 - Comparisons

Resume (suite)

- Concatenation
- Attributes
 - Type related attributes
 - Array related attributes
- Simulation elements
 - Wait statement
 - Assert statement

Lexical elements

Reserved words

Reserved words

abs
access
after
alias
all
and
architecture
array
assert
attribute

begin
block
body
buffer
bus

case
component
configuration
constant

disconnect
downto

else
elsif
end
entity
exit

file
for
function

generate
generic
group
guarded

if
impure
in
inertial
inout
is

label
library
linkage
literal
loop

map
mod
nand
new
next
nor
not
null

of
on
open
or
others
out

package
port
procedure
process
pure

range
record
register
reject
rem
report
return
rol
ror

select
severity
shared
signal
sla
sll
sra
srl
subtype

then
to
transport
type

unaffected
units
until
use

variable

wait
when
While
with

xnor
xor

Declarations

Type declaration
Subtype declaration
Constant declaration
Signal declaration
Variable declaration

Type and library/package std

library std ;

use std.standard.all ;

Type/subtype	Values	Package
boolean	False, true	std.standard
bit	'0', '1'	std.standard
bit_vector	array (natural range <>) of bit	std.standard
character	NUL, SOH, 'a',..'z', '}', '~', DEL	std.standard
string	array (positive range <>) of character	std.standard
integer	-2147483648..2147483647	std.standard
natural	0 .. integer' high	std.standard
positive	1 .. integer' high	std.standard
real	-1.0E308 to 1.0E308	std.standard

!! Integer is now from -2147483648 (-231) to -2147483647 (2**31-1) !!!**

Type and library/package ieee

```
library ieee ;  
use ieee.std_logic_1164.all;
```

Type/subtype	Values	Package
std_ulogic	'U', 'X', '0', '1', 'Z', 'W', 'L', 'H', '-'	ieee.std_logic_1164
std_logic	resolved std_ulogic	ieee.std_logic_1164
X01	'X', '0', '1',	ieee.std_logic_1164
X01Z	'X', '0', '1', 'Z',	ieee.std_logic_1164
UX01	'U', 'X', '0', '1',	ieee.std_logic_1164
UX01Z	'U', 'X', '0', '1', 'Z',	ieee.std_logic_1164
std_ulogic_vector	array (natural range <>) of std_ulogic	ieee.std_logic_1164
std_logic_vector	array (natural range <>) of std_logic	ieee.std_logic_1164

Type and library/package ieee

Standard VHDL Synthesis Package (1076.3, NUMERIC_STD)

```
library ieee ;  
use ieee.std_logic_1164.all;  
use ieee.numeric_std.all;
```

Type/subtype	Values	Package
unsigned	array (natural range <>) of std_logic	ieee.numeric_std
signed		ieee.numeric_std

Type and library/package ieee

Standard VHDL Synthesis Package (1076.3, NUMERIC_BIT)

```
library ieee ;  
use ieee.numeric_bit.all;
```

Type/subtype	Values	Package
unsigned	array (natural range <>) of bit	ieee.numeric_bit
signed		ieee.numeric_bit

Standard VHDL Synthesis Package (1076.3, NUMERIC_STD)

Standard VHDL Synthesis Package (1076.3, NUMERIC_BIT)

```
library ieee ;  
use ieee.std_logic_1164.all;  
use ieee.numeric_std.all;
```

Type/subtype	Values	Package
unsigned	array (natural range <>) of <i>std_logic</i>	ieee.numeric_std
signed		ieee.numeric_std

```
library ieee ;  
use ieee.numeric_bit.all;
```

Type/subtype	Values	Package
unsigned	array (natural range <>) of <i>bit</i>	ieee.numeric_bit
signed		ieee.numeric_bit

Standard VHDL Synthesis Package (1076.3, NUMERIC_STD)

Standard VHDL Synthesis Package (1076.3, NUMERIC_BIT)

```
library ieee ;
use ieee.std_logic_1164.all;
use ieee.std_logic_arith.all;
```

**NOT TO BE USED
ANYMORE**

- from mentor

Type/subtype	Values	Package
unsigned	array (natural range <>) of <i>std_logic</i>	ieee.std_logic_arith
signed		ieee.std_logic_arith

```
library ieee ;
use ieee.numeric_bit.all;
```

Type/subtype	Values	Package
unsigned	array (natural range <>) of <i>bit</i>	ieee.numeric_bit
signed		ieee.numeric_bit

Numbers

- Integer on 32 bits, decimal by default
 - $-2\ 147\ 483\ 647$ **to** $2\ 147\ 483\ 647$
 - 123_456 *_ allowed as separator*
- *base#...#*
 - $2\#1011\#$ *binary*
 - $8\#13\#$ *octal*
 - $16\#B\#$ *hexadecimal*

Numbers for `std_logic_vector` / signed / unsigned

- For *std_logic_vector* / *signed* / *unsigned*
- Character string as "10101100"
- *Facilities with base transformation*
 - *B"1010_1100" → "10101100"*
 - *X"A_C" → "10101100"*
 - *_ allowed as separator for readability*
- *With X"..."* → *number of bits need to be a multiple of 4 (changed in VHDL 2008)*

Component

- **Component *test***

```
generic (size: integer := 8);
```

```
port(
```

```
  A, B : in std_logic_vector(size-1 downto 0);
```

```
  R : out std_logic_vector(size-1 downto 0)
```

```
);
```

```
end component;
```

Entity mode

- **in** input only
- **out** output only
- **inout** bidirectionnel
- **buffer** output used as internal too

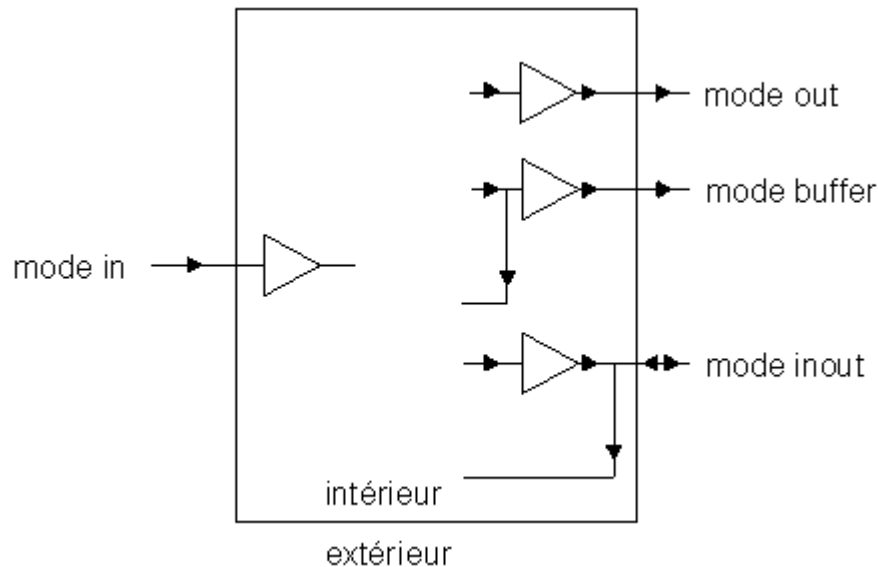

Entity generic and port, , exemple for an Adder

```
library ieee;  
use ieee.std_logic_1164.all; -- library for synthesis and simulation  
use ieee.numeric_std.all; -- library for arithmec operations
```

entity *test* is

generic (*size*: integer := 8);

port(

A, B : in std_logic_vector(size-1 downto 0);

R : out std_logic_vector(size-1 downto 0)

);

end test;

Architecture, exemple for an Adder

architecture *bhv1* of test is

signal OperandA, OperandB : **signed**(size-1 downto 0);

signal Result: **signed** (size-1 downto 0);

begin

OperandA <= signed(A); -- cast std_logic_vector to signed

OperandB <= signed(B);

Result <= OperandA + OperandB; -- Add

R <= std_logic_vector(Result); -- cast from signed to std_logic_vector;

end bhv1;

----- OR -----

architecture *bhv2* of test is

begin

R <= std_logic_vector(signed(A) + signed(B)); -- same without explicite internal signed number

end bhv2;

Type declaration

architecture a of e is

begin
end a;

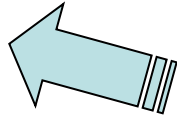

package p is

end p;

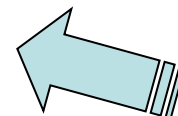

*in the **STD.STANDARD** package:*

type boolean **is** (false, true);

type bit **is** ('0', '1');

type character **is** (NUL, SOH, <...> '}', '~', DEL);

type string **is array**(positive range <>) **of** character;

type bit_vector **is array**(natural range <>) **of** bit;

*in the **IEEE.STD_LOGIC_1164** package:*

type std_uLogic **is** ('U', 'X', '0', '1', 'Z',
'W', 'L', 'H', '-');

type std_uLogic_vector **is**
array(natural range <>) **of** std_uLogic;

*in the **IEEE.NUMERIC_STD** package:*

type unsigned **is array**(natural range <>) **of** std_Logic;

type signed **is array**(natural range <>) **of** std_logic;

Subtype declaration

architecture a of e is

begin
end a;

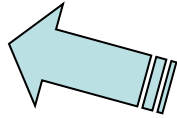

package p is

end p;

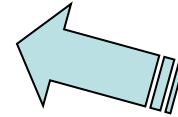

*in the **STD.STANDARD** package:*

subtype natural is integer range 0 to integer'high;
subtype positive is integer range 1 to integer'high;

*in the **IEEE.STD_LOGIC_1164** package:*

subtype std_logic is resolved std_uLogic;
subtype X01 is resolved std_uLogic range 'X' to '1';
subtype X01Z is resolved std_uLogic range 'X' to 'Z';
subtype UX01 is resolved std_uLogic range 'U' to '1';
subtype UX01Z is resolved std_uLogic range 'U' to 'Z';

subtype byte is std_uLogic_vector(7 downto 0);
subtype word is std_uLogic_vector(15 downto 0);
subtype long_word is std_uLogic_vector(31 downto 0);

subtype BCD_digit is unsigned(3 downto 0);
subtype my_counter_type is unsigned(9 downto 0);
subtype sine_wave_type is signed(15 downto 0);

Constant declaration

architecture a of e is

begin
end a;

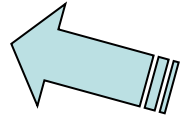

package p is

end p;

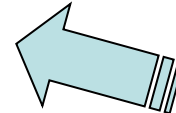

```
constant bit_nb: positive := 4;  
constant min_value: positive := 1;  
constant max_value: positive := 2**bit_nb - 1;
```

```
constant bit_nb: positive := 4;  
constant patt1: unsigned(bit_nb-1 downto 0) := "0101";  
constant patt2: unsigned(bit_nb-1 downto 0) := "1010";
```

```
constant address_nb: positive := 4;  
constant data_register_address : natural:= 0;  
constant control_register_address : natural:= 1;  
constant interrupt_register_address: natural:= 2;  
constant status_register_address : natural:= 3;
```

```
constant clock_period: time := 5 ns;  
constant access_time: time := 2 us;  
constant duty_cycle: time := 33.3 ms;  
constant reaction_time: time := 4 sec;  
constant teaching_period: time := 45 min;
```

Signal declaration

architecture a of e is

begin
end a;

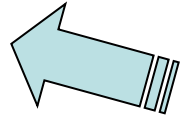

signal s1, s2, s3: std_ulogic;
signal sig1: std_ulogic;
signal sig2: std_ulogic;
signal sig3: std_ulogic;

signal logic_out: std_uLogic;
signal open_drain_out: std_logic;
signal tri_state_out: std_logic;

signal counter: **unsigned**(nb_bits-1 **downto** 0);
signal double: **unsigned**(2*nb_bits-1 **downto** 0);
signal sine: **signed**(nb_bits-1 **downto** 0);

signal *clock_internal*: std_ulogic := '1';



Component declaration

```
architecture a of e is
```

```
begin  
end a;
```

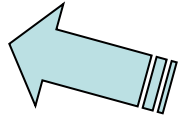

```
component test
```

```
generic (size: integer := 8);
```

```
port(
```

```
  A, B : in std_logic_vector(size-1 downto 0);
```

```
  R : out std_logic_vector(size-1 downto 0)
```

```
);
```

```
end component;
```

Variable declaration

```
p: process (s_list)
```

```
begin
```

```
end process p;
```

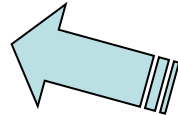

```
variable v1, v2, v3: std_ulogic;
```

```
variable var1: std_ulogic;
```

```
variable var2: std_ulogic;
```

```
variable var3: std_ulogic;
```

```
variable counter: unsigned(nb_bits-1 downto 0);
```

```
variable double: unsigned(2*nb_bits-1 downto 0);
```

```
variable sine: signed(nb_bits-1 downto 0);
```

Type conversion *numeric_std* \leftrightarrow *std_logic_1164*

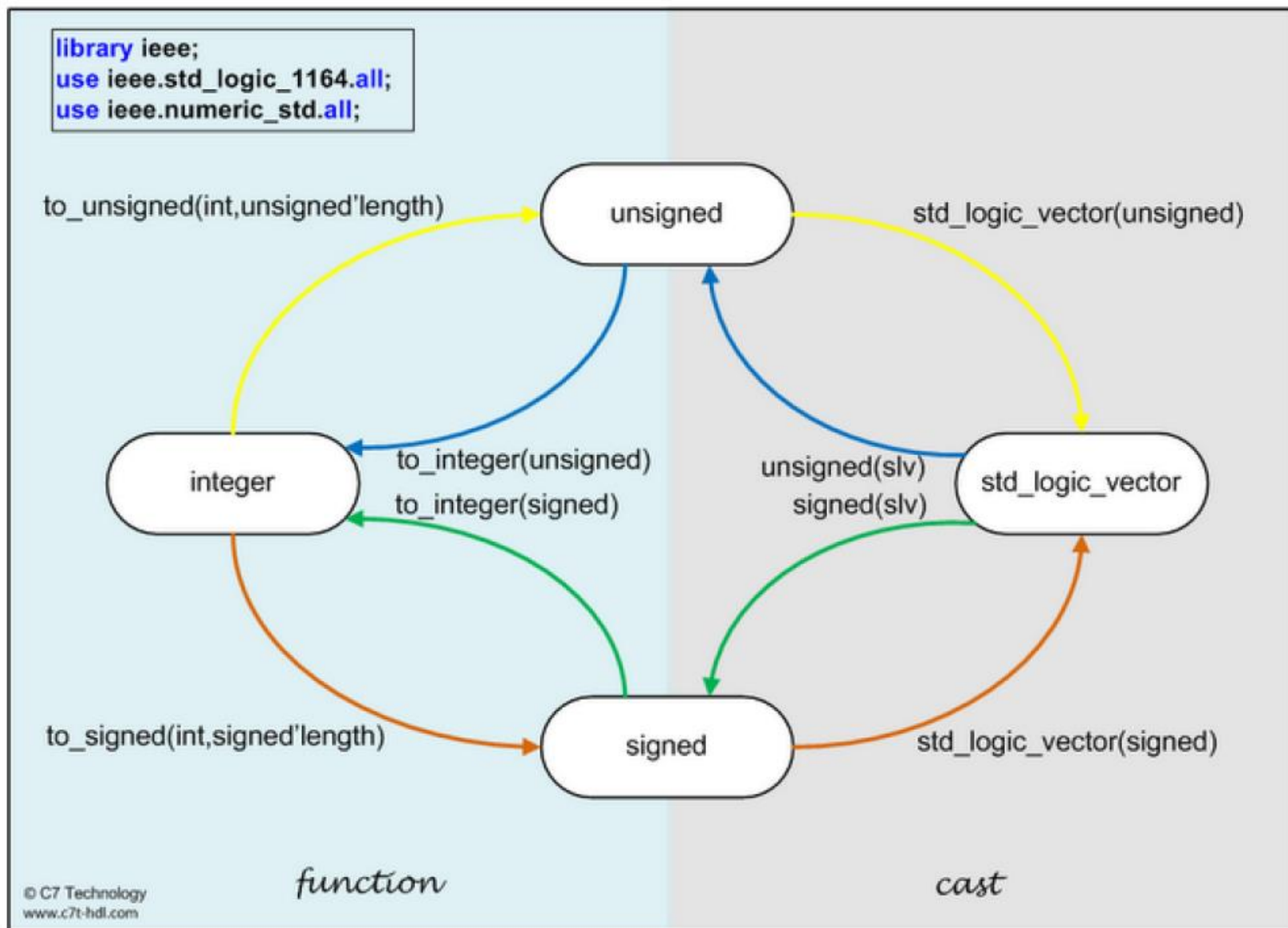

Concurrent statements

Signal assignment

Conditional assignment:
When statement
With statement

Process statement

Structural

Component declaration

Components connection/instantiation

Component declaration



```
entity test  
generic (size: integer := 8);  
port(  
  A, B : in std_logic_vector(size-1 downto 0);  
  R : out std_logic_vector(size-1 downto 0)  
);  
end entity test;
```

```
architecture a of test is  
begin  
  R <= A and B; -- and on bit to bit of A, B to R  
end a;
```

```
component test  
generic (size: integer := 8);  
port(  
  A, B : in std_logic_vector(size-1 downto 0);  
  R : out std_logic_vector(size-1 downto 0)  
);  
end component test;
```

Components connection/instantiation

```
entity try_component is
  generic (size: integer := 8);
  port(
    X, Y : in std_logic_vector(size-1 downto 0);
    Result : out std_logic_vector(size-1 downto 0)
  );
end entity;
```

```
architecture a of try_component is
  component test
    generic (size: integer := 8);
    port(
      A, B : in std_logic_vector(size-1 downto 0);
      R : out std_logic_vector(size-1 downto 0)
    );
  end component;
  signal topA, topB, topR : std_logic_vector(size-1 downto 0);
begin
  U1: test generic map(size => size)
    port map( A => topA,
              B => topB,
              R => topR);
end a;
```

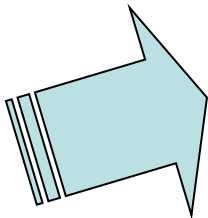
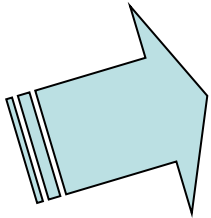

Signal assignment

```
architecture bhv of e is  
begin  
end bhv;
```

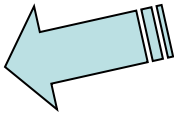

```
y1 <= a;  
y2 <= a and b;  
y3 <= to_integer(a);
```

```
y1 <= a;  
y2 <= a after 2 ns;  
y3 <= inertial a after 1 ns;  
y4 <= transport a after 4 ns;  
y5 <= reject 1 ns inertial a after 5 ns;
```



```
y <= a and b after 5 ns;
```

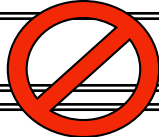

```
y <= '0',  
'1' after 2 ns,  
'0' after 4 ns,  
'X' after 10 ns,  
'1' after 15 ns,  
'-' after 23 ns;
```



When statement (conditional assignment)

```
architecture a of e is  
begin  
end a;
```

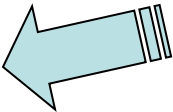

```
y <= x0 when sel = '0' else  
x1 when sel = '1' else  
'0';
```

```
y <= x0 after 2 ns when sel = '0' else  
x1 after 3 ns when sel = '1';
```



With statement (conditional assignment)

```
architecture a of e is  
begin  
end a;
```

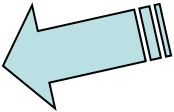

```
mux: with sel select  
y <=      x0 when "00",  
          x1 when "01",  
          x2 when "10",  
          x3 when "11",  
          'X' when others;
```

```
decoder: with binary_code select  
y <=      transport "0001" after 2 ns when "00",  
          "0010" after 5 ns when "01",  
          "0100" after 3 ns when "10",  
          "1000" after 4 ns when "11",  
          "XXXX" when others;
```



Process statement

```
architecture a of e is  
begin  
end a;
```

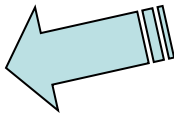

```
mux: process(sel, x0, x1)  
begin  
    if sel = '0' then  
        y <= x0;  
    elsif sel = '1' then  
        y <= x1;  
    else  
        y <= 'X';  
    end if;  
end process mux;
```

```
count: process(reset, clock)  
begin  
    if reset = '1' then  
        counter <= (others => '0');  
    elsif rising_edge(clock) then  
        counter <= counter + 1;    -- counter as unsigned  
    end if;  
end process count;
```

Sequential statements *in a process*

Variable assignment :=
If statement
Case statement
Loop statement

Variable assignment

```
p: process (s_list)
```

```
begin
```

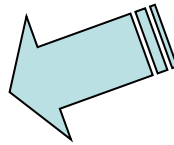

```
end process p;
```

```
y1 := a;
```

```
y2 := a and b;
```

```
y3 := to_integer(a);
```

Variables are available in a process only (changed with version 2008, but we don't know how).

In a process, the variable assignment is evaluated and assigned immediately

→ The new value is available for immediate use in a next statement

if statement

```
p: process (s_list)
begin
    
end process p;
```

```
if gate = '1' then
    q <= d;
end if;
```

```
if sel = '0' then
    y1 <= x0;
    y2 <= x1;
    y3 <= '0';
else
    y1 <= x1;
    y2 <= x0;
    y3 <= '1';
end if;
```

```
if sel = '0' then
    y <= x0;
else
    y <= x1;
end if;
```

```
if sel = 0 then
    y <= x0;
elsif sel = 1 then
    y <= x1;
elsif sel = 2 then
    y <= x2;
else
    y <= x3;
end if;
```

case statement

```
p: process (s_list)
begin
    ←
end process p;
```

case sel is

```
when "00" => y <= x0;
when "01" => y <= x1;
when "10" => y <= x2;
when "11" => y <= x3;
when others => null;
end case;
```

case opCode is

```
when add =>          y1 <= x0;
                    y2 <= x1;
when sub =>          y1 <= x1;
                    y2 <= x0;
when others => null;
end case;
```

case value is

```
when 1 =>  nBits <= 1;
when 2|3 => nBits <= 2;
when 4 to 7 => nBits <= 3;
when 8 to 15 => nBits <= 4;
when others => nBits <= 0;
end case;
```

case to_integer(sel) is

```
when 0 => y <= x0 after 1 ns;
when 1 => y <= x1 after 1 ns;
when 2 => y <= x2 after 1 ns;
when 3 => y <= x3 after 1 ns;
when others => y <= 'X';
end case;
```



Loop statement

```
p: process (s_list)
begin
    
end process p;
```

```
for xIndex in 1 to xSize loop
    for yIndex in 1 to ySize loop
        if xIndex = yIndex then
            y(xIndex, yIndex) <= '1';
        else
            y(xIndex, yIndex) <= '0';
        end if;
    end loop;
end loop;
```

```
multipl:
    for indexB in 0 to nBits-1 loop
        partialProd:
            for indexA in nBits-1 downto 0 loop
                partProd(indexA) <= a(indexA) and b(indexB);
            end loop partialProd;
            cumSum(indexB+1) <= cumSum(indexB) + partProd;
        end loop multipl;
```

Operators

Logic operators
Arithmetic operators
Comparisons
Concatenation

Logic operators (from ieee.STD_LOGIC_1164)

<i>operator</i>	<i>description</i>
not	inversion
and	logical AND
or	logical OR
xor	exclusive-OR
nand	NAND-function
nor	NOR-function
xnor	exclusive-NOR

Logic operators (from ieee.numeric_std)

<i>operator</i>		<i>description</i>
	not	inversion
	and	logical AND
	or	logical OR
	xor	exclusive-OR
	nand	NAND-function
	nor	NOR-function
	xnor	exclusive-NOR
	non compatible VHDL 1076-1987	
SHIFT_LEFT	sll	logical shift left
SHIFT_RIGHT	srl	logical shift right
ROTATE_LEFT	rol	rotate left
ROTATE_RIGHT	ror	rotate right

Logic operators

```
y <= a and b;
```

```
if (a = '1') and (b = '1') then  
    y <= '1';  
else  
    y <= '0';  
end if;
```

```
if (a and b) = '1' then  
    y <= '1';  
else  
    y <= '0';  
end if;
```

```
count <= count sll 3;
```

Arithmetic operators

<i>operator</i>	<i>description</i>
+	addition
-	substraction
*	multiplication
/	division
**	power
abs	absolute value
mod	modulo
rem	remainder of the division
sla	arithmetic shift left
sra	arithmetic shift right

Arithmetic operators

```
maxUnsigned <= 2**nBits - 1;  
maxSigned <= 2**(nBits-1) - 1;
```

Comparisons

<i>operator</i>	<i>description</i>
=	equal to
/=	not equal to
<	smaller than
>	greater than
<=	smaller than or equal to
>=	greater than or equal to

Comparisons

```
if counter > 0 then  
    counter <= counter -1;  
end if;
```

```
if counter /= 0 then  
    counterRunning <= '1';  
else  
    counterRunning <= '0';  
end if;
```

Concatenation

<i>operator</i>	<i>description</i>
&	concatenation

```
address <= "1111" & "1100";
```

```
constant CLR: std_logic_vector(1 to 4) := "0000";
constant ADD: std_logic_vector(1 to 4) := "0001";
constant CMP: std_logic_vector(1 to 4) := "0010";
constant BRZ: std_logic_vector(1 to 4) := "0011";
constant R0 : std_logic_vector(1 to 2) := "00";
constant DC : std_logic_vector(1 to 2) := "--";
constant reg : std_logic := '0';
constant imm : std_logic := '1';

type ROMArrayType is array(0 to 255) of std_logic_vector(1 to 9);

constant ROMArray: ROMArrayType := (
    0 => ( CLR & DC & R0 & reg ),
    1 => ( ADD & "01" & R0 & imm ),
    2 => ( CMP & "11" & R0 & imm ),
    3 => ( BRZ & "0001" & '-' ),
    4 to romArray'length-1 => (others => '0') );
```

Attributes

Type related attributes
Array related attributes

Type related attributes

<i>ATTRIBUTE</i>	<i>RESULT</i>
T'base	the base type of T
T'left	the left bound of T
T'right	the right bound of T
T'high	the upper bound of T
T'low	the lower bound of T
T'pos(X)	the position number of X in T
T'val(N)	the value of position number N in T
T'succ(X)	the successor of X in T
T'pred(X)	the predecessor of X in T
T'leftOf(X)	the element left of X in T
T'rightOf(X)	the element right of X in T

Type related attributes

```
signal counterInt: unsigned;  
signal count1: unsigned(counter'range);  
signal count2: unsigned(counter'length-1 downto 0);  
...  
flip: process(count1)  
begin  
    for index in count1'low to count1'high loop  
        count2(index) <= count1(count1'length-index);  
    end loop;  
end process flip;
```

Array related attributes

<i>ATTRIBUTE</i>	<i>RESULT</i>
A'left	the left bound of A
A'right	the right bound of A
A'high	the upper bound of A
A'low	the lower bound of A
A'range	the range of A
A'reverse_range	the range of A in reverse order
A'length	the size of the range of A

Array related attributes

```
type stateType is (reset, wait, go);  
signal state: stateType;  
...  
evalNextState: process(reset, clock)  
begin  
    if reset = '1' then  
        state <= stateType'left;  
    elsif rising_edge(clock) then  
        ...  
    end if;  
end process evalNextState;
```

Simulation elements



Wait statement
Assert statement

Wait statement

```
p: process (s_list)
begin
    
end process p;
```

```
test: process
begin
    testMode <= '0';
    dataByte <= "11001111";
    startSend <= '1';
    wait for 4*clockPeriod;
    startSend <= '0';
    wait for 8*clockPeriod;
    testMode <= '1';
    dataByte <= "11111100";
    startSend <= '1';
    wait for 4*clockPeriod;
    startSend <= '0';
    wait;
end process test;
```

```
test: process
begin
    a <= '0';
    b <= '0';
    wait for simulStep;
    error <= y xor '0';
    a <= '1';
    b <= '1';
    wait for simulStep;
    error <= y xor '1';
end process test;
```

```
test: process
begin
    playVectors: for index in stimuli'range loop
        dataByte <= stimuli(index);
        wait for clockPeriod;
        assert codedWord = expected(index);
        wait for clockPeriod;
    end loop playVectors;
    wait;
end process test;
```

Assert statement

```
p: process (s_list)
begin
    
end process p;
```

```
assert output = '1';
```

```
assert output = '1'
report "output was '0!'"
severity error;
```

```
assert output = '1'
report "output was '0!';
```

```
in the STD.STANDARD package:
type severity_level is (    note,
                               warning,
                               error,
                               failure);
```

Resume

Resume [2](#)

Lexical elements [6](#)

Declarations [8](#)

Type and library/package [9](#)

Numbers [15](#)

Entity mode [18](#)

Entity port/generic [19](#)

Component [17](#)

Architecture [20](#)

Concurrent statements [28](#)

Sequential statements [34](#)

Operators [39](#)

Attributes [48](#)

Simulation elements [53](#)

Arithmetic operators [43](#)

Array related attributes [51](#)

Assert statement [55](#)

Case statement [37](#)

Comparisons [45](#)

Concatenation [47](#)

Constant declaration [23](#)

If statement [36](#)

Logic operators [40](#)

Loop statement [38](#)

Process statement [33](#)

Reserved words [7](#)

Type declaration [21](#)

Type related attributes [49](#)

Signal assignment [30](#)

Signal declaration [24](#)

Subtype declaration [22](#)

Variable assignment [35](#)

Variable declaration [26](#)

Wait statement [54](#)

When statement [31](#)

With statement [32](#)

ToDo

Some examples

- DFF
- Reset
- State machine
- Counter
- Generate
- Integer <->(un)signed <->
std_logic_vector