

Renewable Energy

Prof. Sophia Haussener

MER Jan van Herle

Laboratory of Renewable Energy Sciences and Engineering

Conversion pathways

- Solar energy conversion

- Solar to electric:
photovoltaic

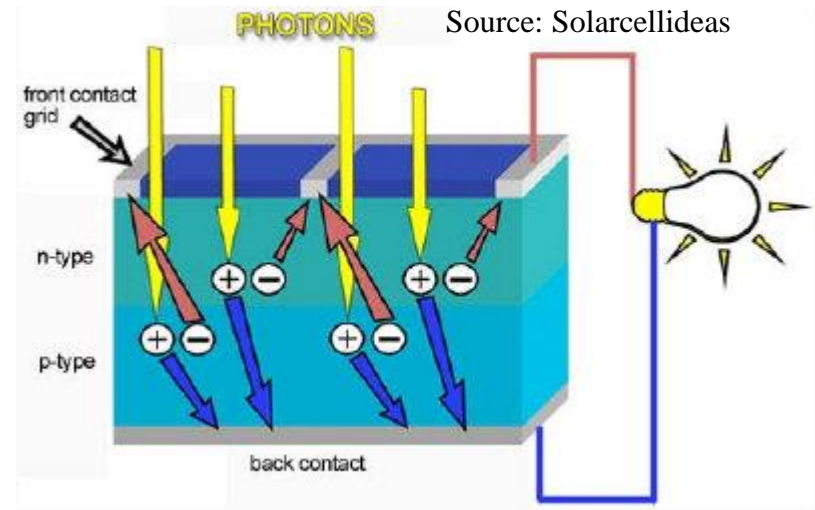

- Solar to electric:
solar thermal plus power cycle

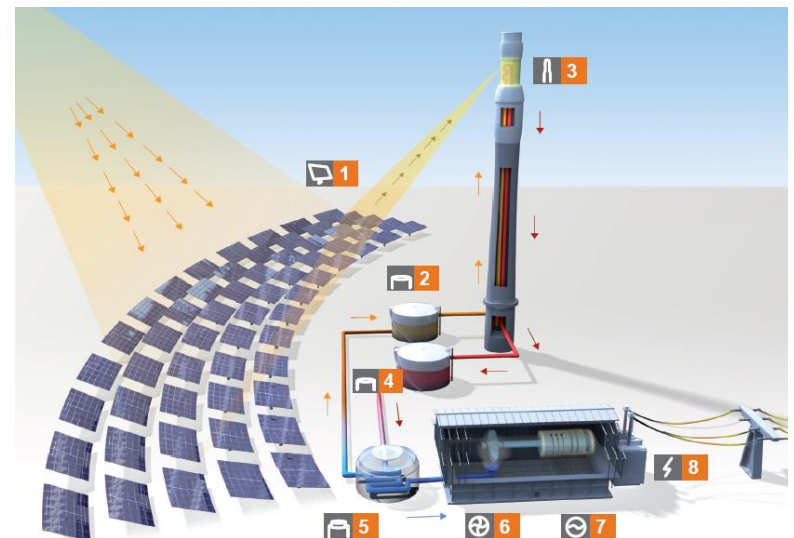

Renewable Energy

- Outline:
 - Fundamentals
 - History
 - Solar irradiation characteristics
 - Semiconductors
 - Working principle
 - Efficiency
 - PV technologies
 - Sustainability
 - Market
 - Aesthetics

Learning outcomes of today's lecture

- Solar to electricity via PV:
 - Working principle of photovoltaic cell
 - Efficiency calculation for ideal cell
 - What influences efficiency (operating conditions)
 - Materials and their influence on efficiency
 - Overview of various PV technologies
 - Current efficiencies and potential
 - Differences, advantages and disadvantages

History

- 1839: E. Becquerel discovers photovoltaic effect (at age of 19), AgCl was placed in an acidic solution while connected to Pt-electrodes, generating voltage and current, which increased with illumination

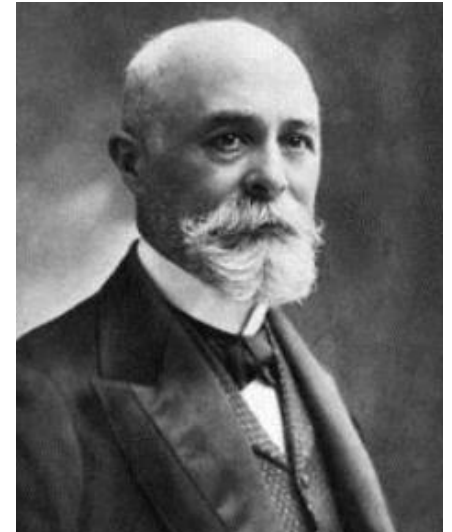

- 1883: Charles Fritts, an American inventor, described the first solar cells made from selenium wafers. Based on W. Smith and W. Adams investigations
- 1904: Photovoltaic effect is theoretically described by A. Einstein

History

- 1954: Bell Laboratories, D.M. Chapin, C.S. Fuller, and G.L. Pearson, published the results of their discovery of 4.5% efficient Si solar cells, raised to 6% only a few months later
- Early 1950 and later: market driven by space applications
- 1963: Sharp Corporations developed first useable Si cell-based modules
- 1970 and later: First use of PV technology on earth
- See more:
<http://www.pvresources.com/Introduction/HistoricalOverview.aspx>

http://www.nrel.gov/education/pdfs/educational_resources/high_school/solar_cell_history.pdf

Solar irradiation characteristics

- Solar irradiation:
 - Power density [W/m^2] is location, date, and time dependent:

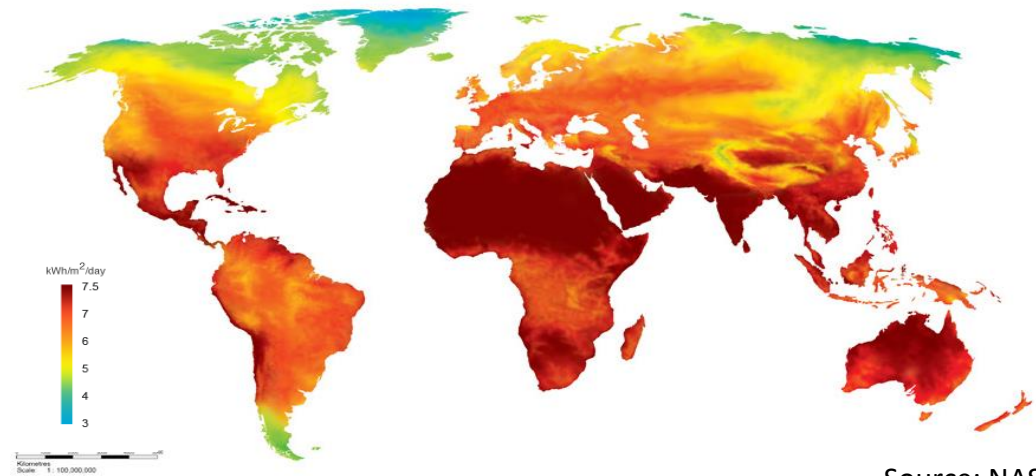

Source: NASA

- Spectral-dependence given by black-body radiation at 5800 K (sun) and absorption in atmosphere:

- Energy of photon: $E_{\text{photon}} = \frac{hc}{\lambda}$

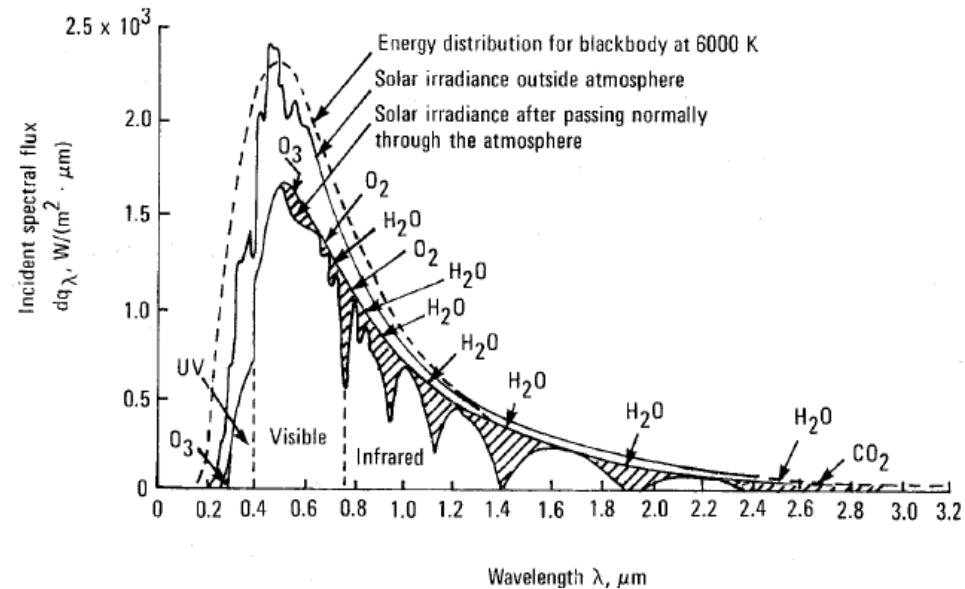

Solar irradiation characteristics

- Solar radiation:
 - Black body emissive power:

$$E_{\lambda b}(\lambda, T) = \frac{2hc_0^2}{\lambda^5 (e^{hc_0/(k\lambda T)} - 1)}$$

$$E_b = \int_0^{\infty} E_{\lambda b} d\lambda = \sigma T^4 \quad \sigma = \frac{2hc_0^2 \pi^5 k^4}{15h^4 c_0^4}$$

$$F_{\lambda_1-\lambda_2} = \frac{\int_{\lambda_1}^{\lambda_2} E_{\lambda b} d\lambda}{\int_0^{\infty} E_{\lambda b} d\lambda} = \frac{\int_{\lambda_1}^{\lambda_2} E_{\lambda b} d\lambda}{\sigma T^4}$$

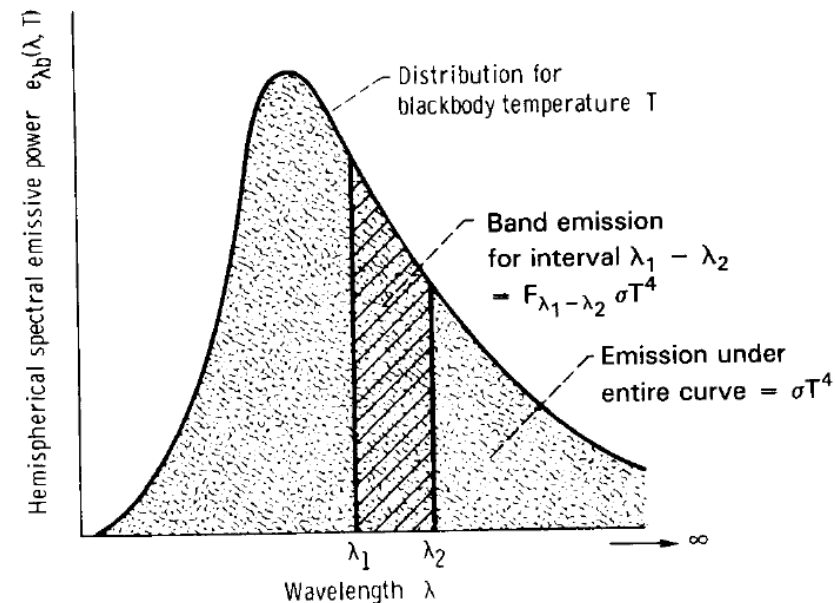
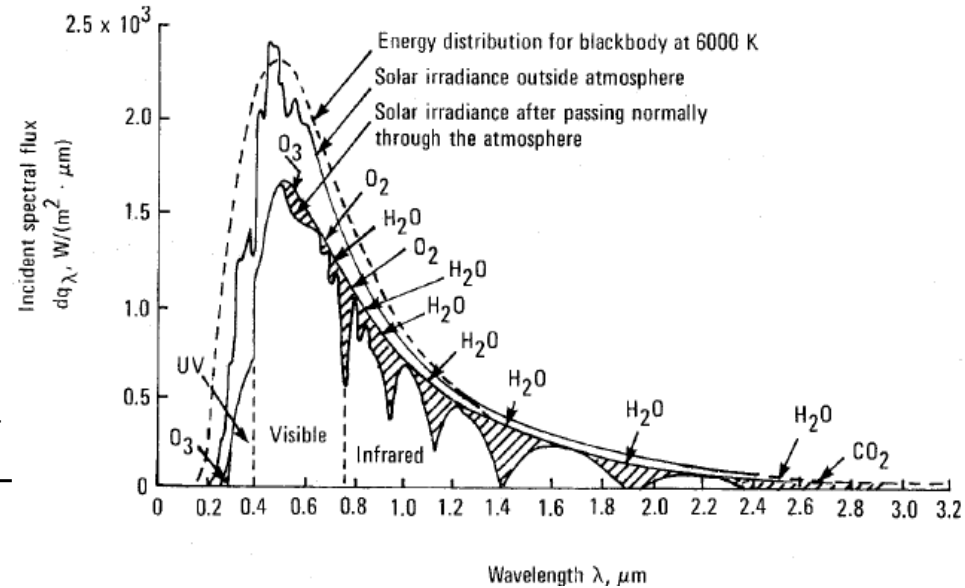

Solar irradiation characteristics

- Definitions:

- Air mass (AM):

AM is the path length which light travels through the atmosphere normalized to the shortest possible path length (sun is directly overhead).

AM quantifies the reduction in the power of light as it passes through the atmosphere and is absorbed by air and dust:

$$AM = \frac{1}{\cos \theta} = \frac{Y}{X}$$

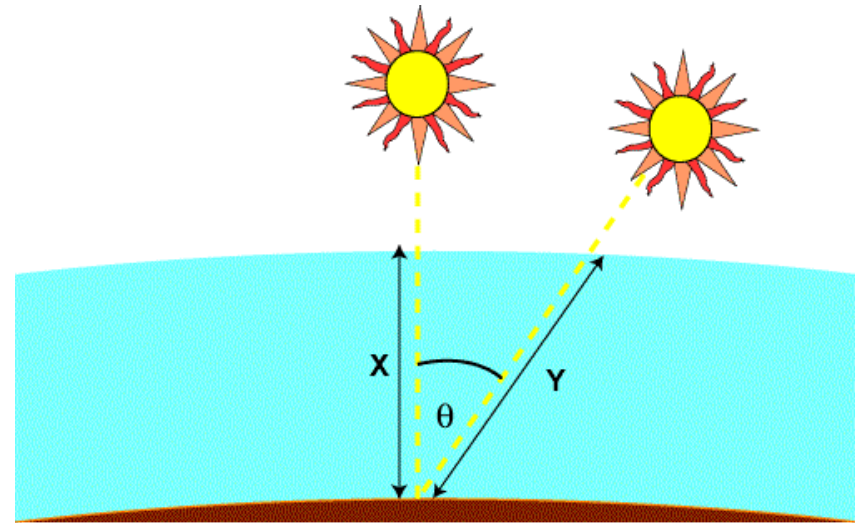

- AM0: solar spectrum outside of the atmosphere with 1367 W/m²
- AMx defines both the spectrum and the power density
- AM1.5D = only direct radiation, normalized at 900 W/m²
- AM1.5G = including diffuse radiation, normalized at 1000 W/m²

Working principle

The operating principle of a solar cell relies on the **direct** conversion:

- 1) of incident energy of photons (solar spectrum) on a semiconductor
- 2) in electricity, by creation of charge carrier pairs (electrons, n^- , and holes, p^+) in the semiconductor
- 3) separation of these thanks to an internal electrical field (p-n junction)

Semiconductors

- Semiconductor:
 - Materials which have electrical conductivity between a conductor and an insulator
 - Properties dependent on state

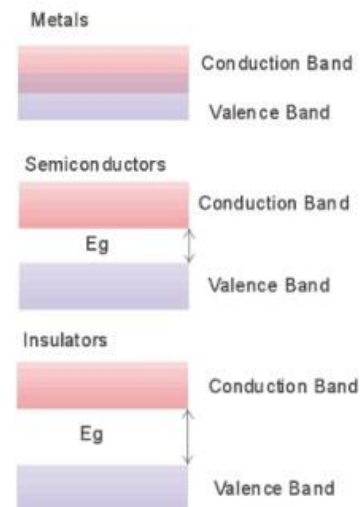

- Three important types:
 - Elemental: elements mainly of group IV, e.g. Si, or Ge
 - Compounds: Elemental combinations of
 - Groups III-V, e.g. GaAs
 - Groups II-VI, e.g. CdTe
 - Alloys: $\text{Si}_x\text{Ge}_{(1-x)}$ or $\text{Al}_x\text{Ga}_{(1-x)}\text{As}$

						III A	IV A	V A	VI A	VII A	VIII A
						5	6	7	8	9	10
						B	C	N	O	F	He
						10.811	12.011	14.007	15.999	18.998	4.003
						13	14	15	16	17	18
						Al	Si	P	S	Cl	Ar
						26.982	28.086	30.974	32.064	35.453	39.948
29	30	31	32	33	34	35	36				
Cu	Zn	Ga	Ge	As	Se	Br	Kr				
63.54	65.37	69.72	72.59	74.922	78.96	79.909	83.80				
47	48	49	50	51	52	53	54				
Ag	Cd	In	Sn	Sb	Te	I	Xe				
107.870	112.40	114.82	118.69	121.75	127.60	126.904	131.30				
79	80	81	82	83	84	85	86				
Au	Hg	Tl	Pb	Bi	Po	At	Rn				
196.967	200.59	204.37	207.19	208.980	(210)	(210)	(222)				

Semiconductors

- Semiconductor:
 - Excited electrons can move in conduction band, leave behind a hole; electron and hole pairs contribute to conduction
 - Intrinsic charge carrier: $f(\text{temperature, band gap})$
e.g. for Si (Misiakos):
$$n_i = 5.29 \cdot 10^{19} (T / 300)^{2.54} \exp(-6726 / T)$$
 - Additionally, doping can be used to increase charge carriers:
 - n-doped: material with more valence electrons than base material (electrons are majority carrier)
 - p-doped: materials with less valence electrons than base material (holes are majority carrier)

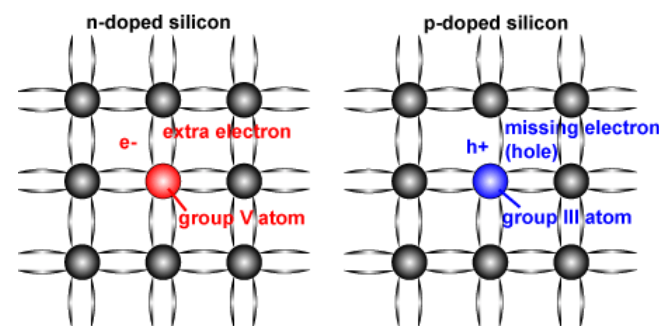

Semiconductors

- Semiconductor under irradiation:
 - Electron-hole pairs are generated by solar irradiation, if the energy is larger than the band gap energy they are absorbed

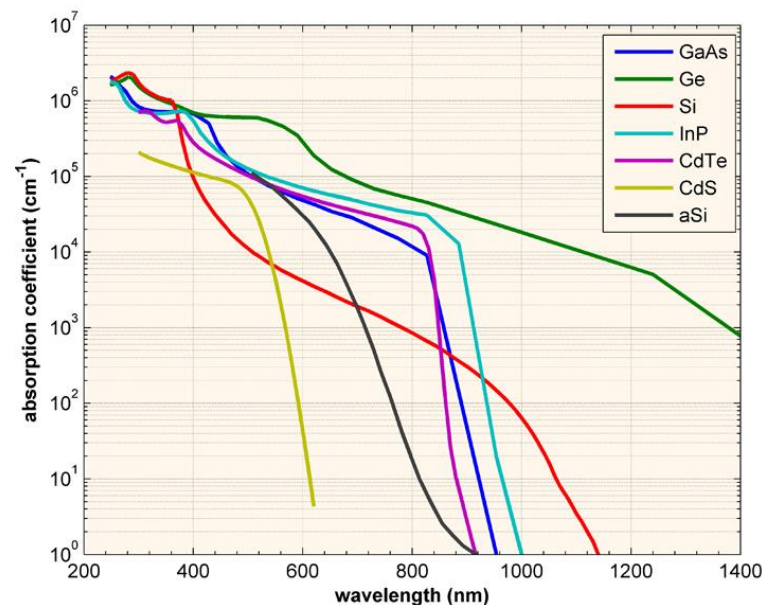

- Absorption depth is inversely proportional to absorption coefficient, according to Beer's law:

$$I = I_0 \exp(-\alpha l) \qquad \overset{l=1/\alpha}{I = I_0 \exp(-1) \rightarrow 0.36 \cdot I_0}$$

- Generation rate (electron-hole-pairs): $\left| \frac{dI}{dl} \right| = \alpha N_0 \exp(-\alpha l)$

Photonflux [# / m² / s] = I/E

Semiconductors

- Semiconductor under irradiation:
 - Once an electron hole-pair is generated, they can recombine:

- Radiative recombination
- Shockley-Read-Hall recomb.
- Auger recombination

$$\left. \begin{array}{l} \text{Recombination rate} \\ \text{Diffusion coef.} \end{array} \right\} \frac{1}{\tau} = \frac{1}{\tau_{rr}} + \frac{1}{\tau_{ar}} + \frac{1}{\tau_{srh}} = \frac{R}{\Delta n} = \frac{D}{l^2}$$

Diffusion length

- Free charge carriers randomly moving, but no net movement
- Net movement only if «driver»:

- Diffuse in the material according to the concentration gradient

$$J_{x,n} = qD_n \frac{dn}{dx} \quad J_{x,p} = qD_p \frac{dp}{dx}$$

- Drift in the material according to an electric field

$$J_{x,n} = qn\mu_n E_x \quad J_{x,p} = qp\mu_p E_x$$

- Continuity equation: $\frac{dn}{dt} = \frac{1}{q} \frac{dJ_n}{dx} + G - R$ $\frac{dp}{dt} = -\frac{1}{q} \frac{dJ_p}{dx} + G - R$

- Plus Poisson eq. for electric field

Working principle

- A solar cell is an electronic device which directly converts sunlight into electricity.
Light shining on the solar cell produces both a current and a voltage to generate electric power.

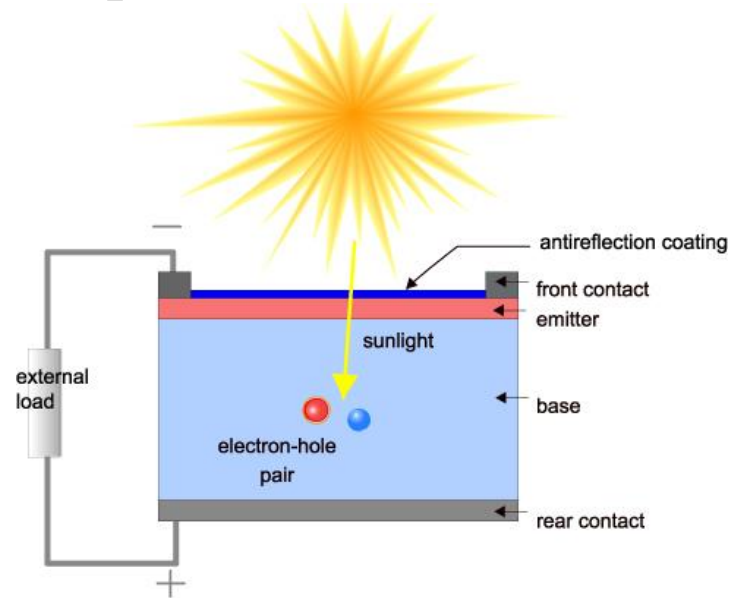

- This process requires
 - a material in which the absorption of light raises an electron to a higher energy state
 - the movement of this higher energy electron from the solar cell into an external circuit. The electron then dissipates its energy in the external circuit and returns to the solar cell.

Working principle

- To efficiently separate the generated electron-hole pairs before they recombine, often electric field required
- pn-junction a possible approach to generate electric field:

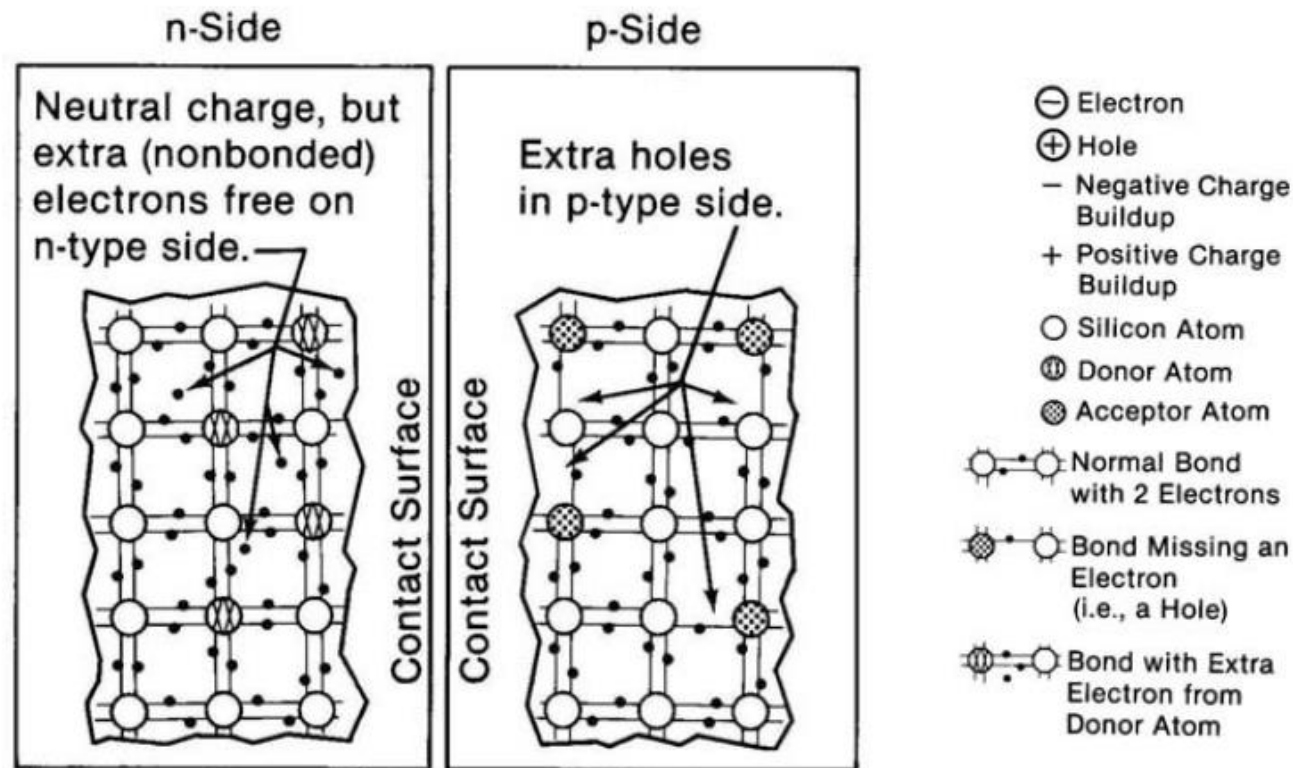

Basic photovoltaic principles and methods, 1981.

Working principle

- pn-junction:

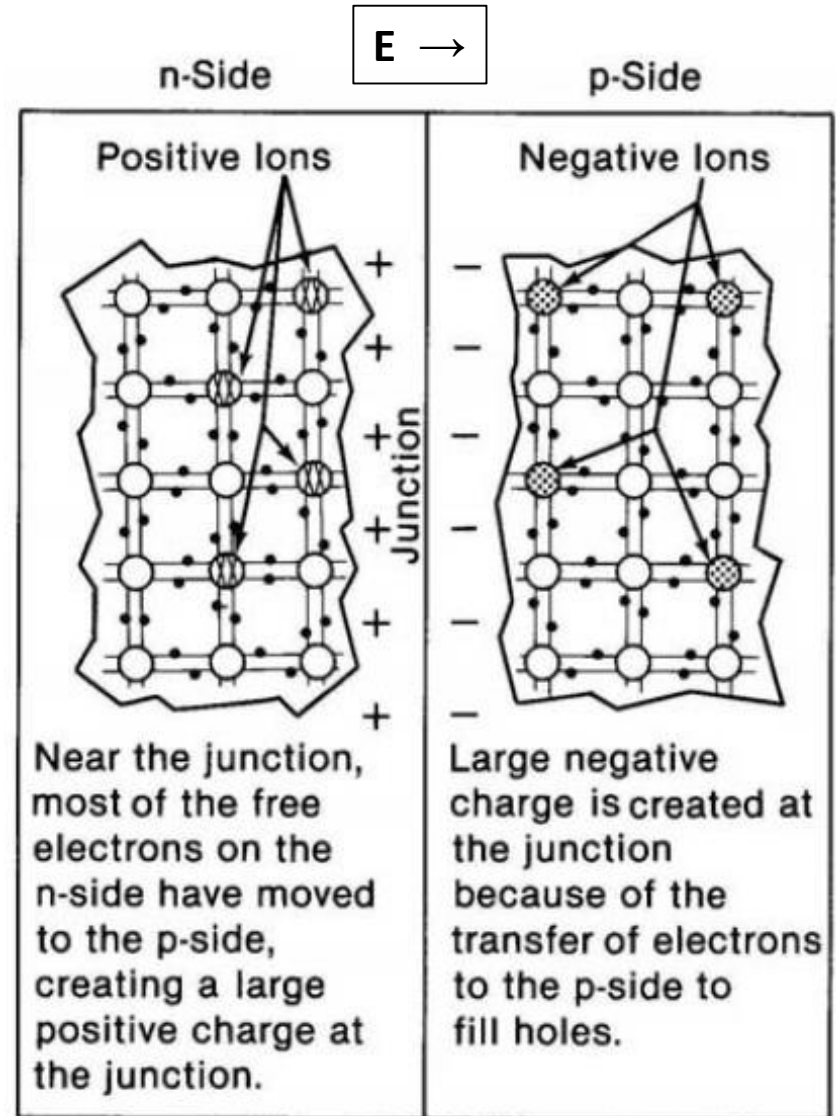
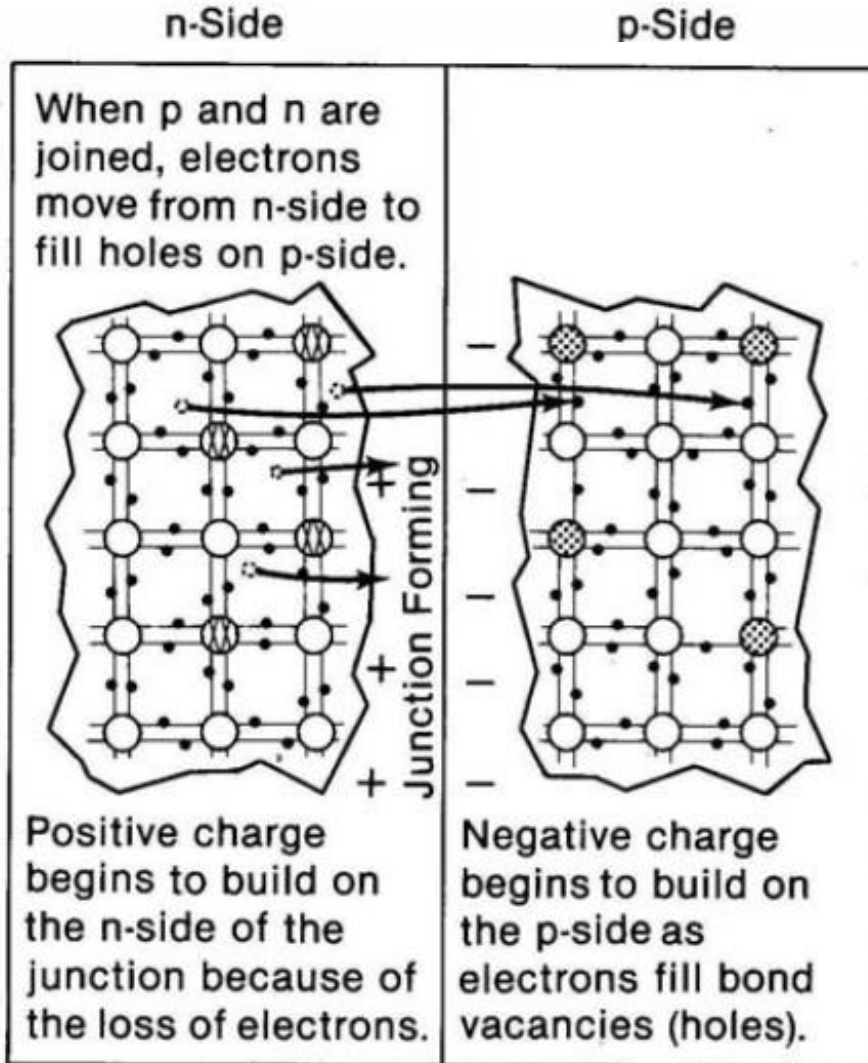

Working principle

- pn-junction:
 - At equilibrium drift and diffusion currents are equal, zero net current

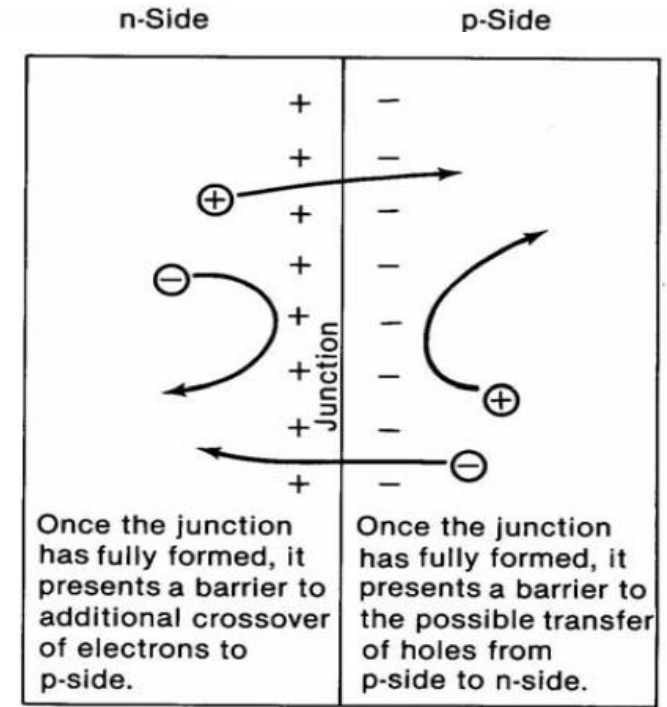

Basic photovoltaic principles and methods, 1981.

- Behaves like a diode:

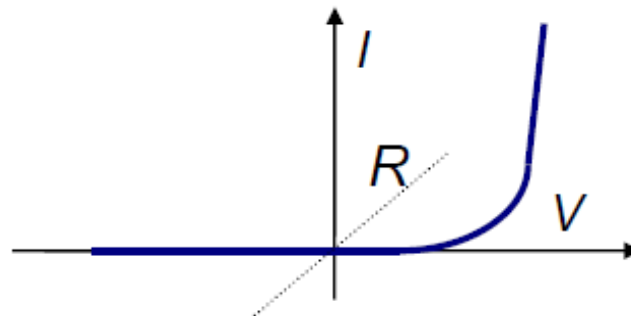
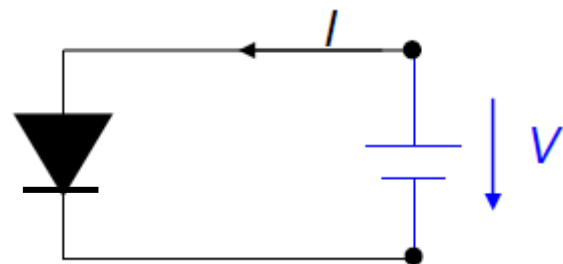

$$I = I_0 \left(\exp\left(\frac{qV}{kT}\right) - 1 \right)$$

Working principle

- pn-junction in a photovoltaic cell:

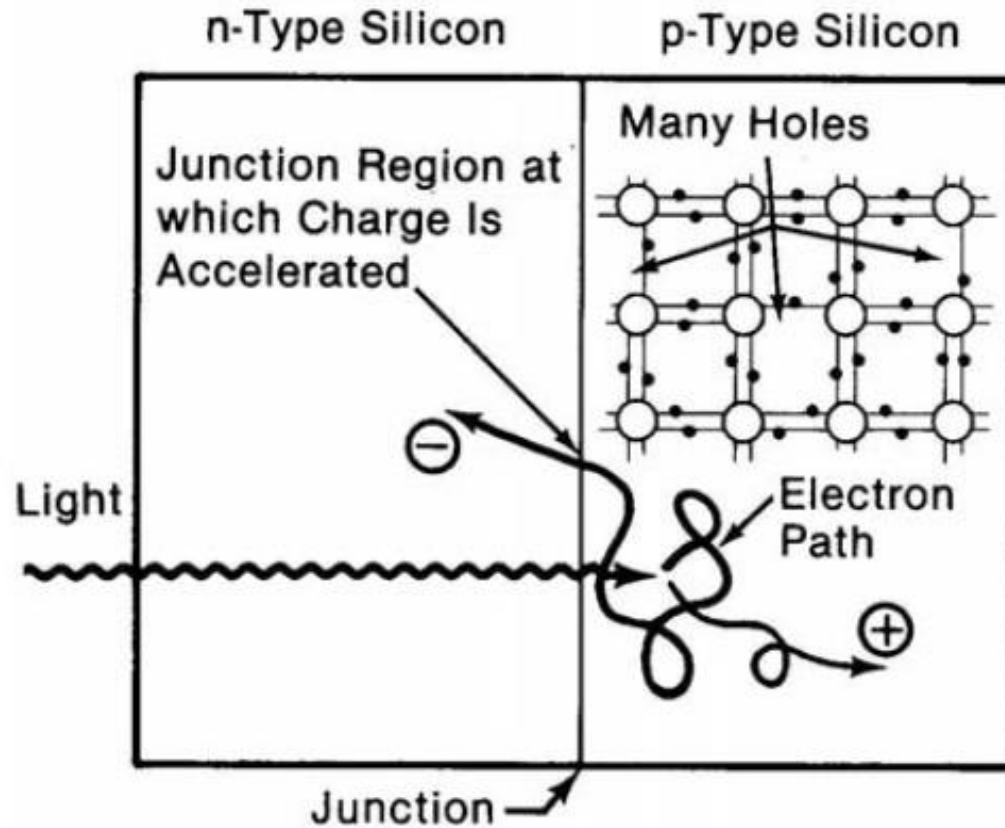

Basic photovoltaic principles and methods, 1981.

Working principle

- pn-junction in a photovoltaic cell:
 - Light induced current

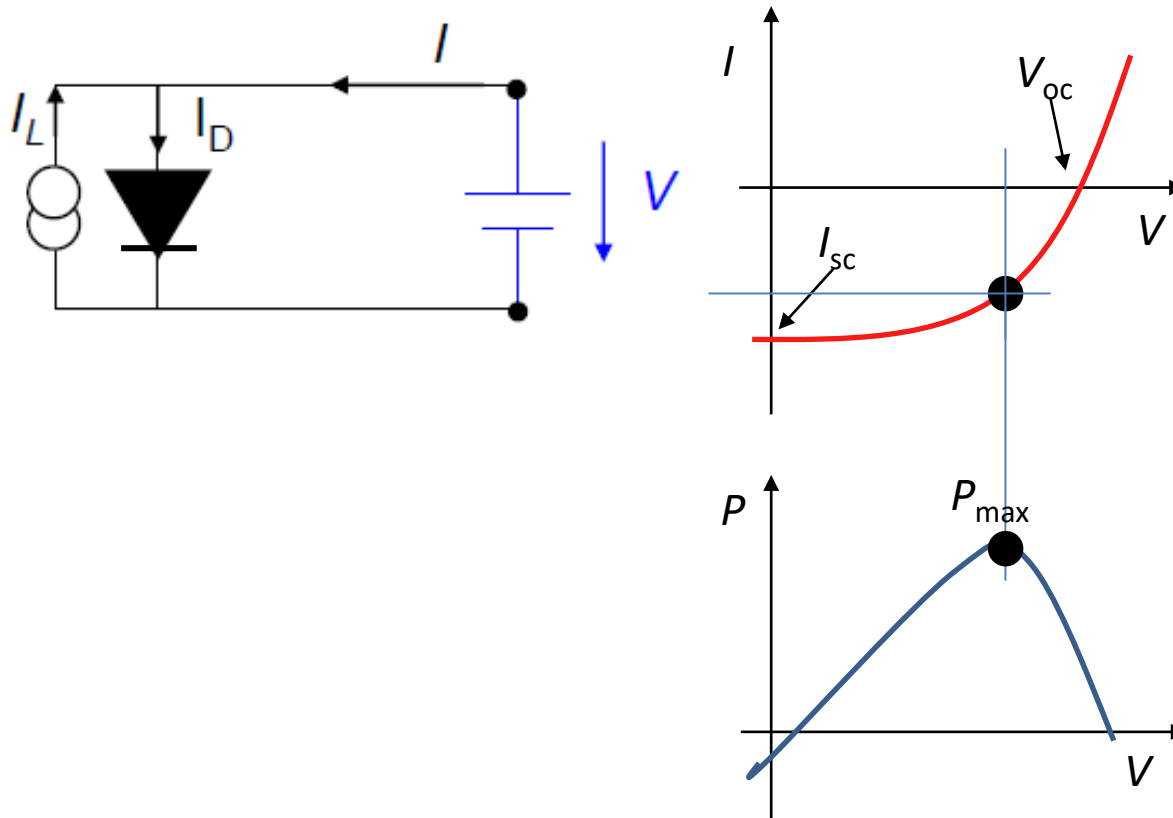

$$\begin{aligned} I &= -I_L + I_D \\ &= -I_L + I_0 \left(\exp\left(\frac{qV}{kT}\right) - 1 \right) \end{aligned}$$

Power: $I \cdot V$

Maximum power: $I_{pmax} \cdot V_{pmax}$

Fill factor: $FF = I_{pmax} \cdot V_{pmax} / (I_{sc} \cdot V_{oc})$

Working principle

- pn-junction in a photovoltaic cell:

- Ideal diode

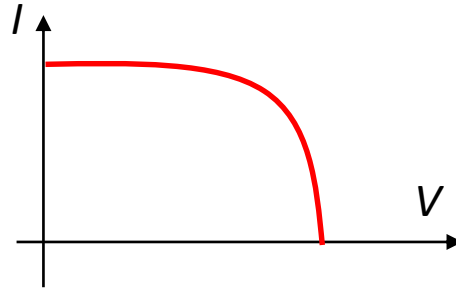
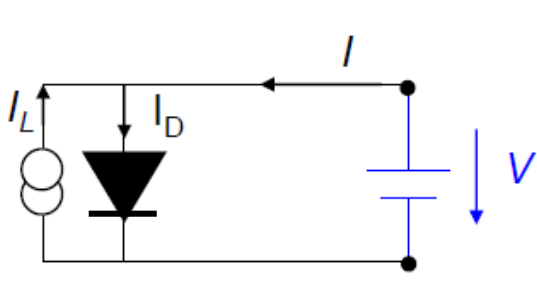

$$I = I_L - I_0 \left(\exp\left(\frac{qV}{kT}\right) - 1 \right)$$

- Realistic: parasitic resistances

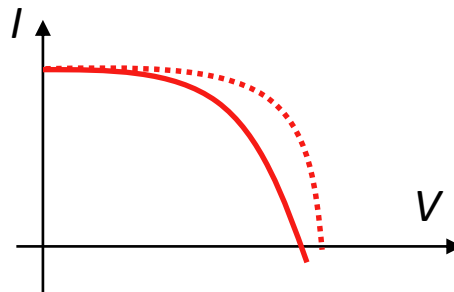
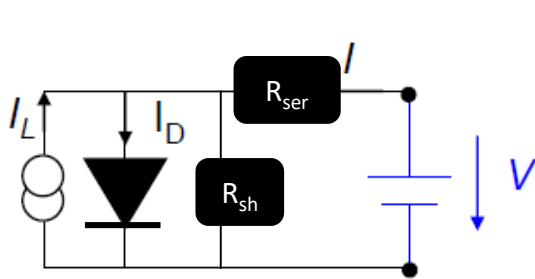

$$I = I_L - I_0 \left(\exp\left(\frac{qV + qiR_{ser}}{kT}\right) - 1 \right) - \frac{V + iR_{ser}}{R_{sh}}$$

Working principle

- pn-junction in a photovoltaic cell and charge collection:
 - Charge collection:

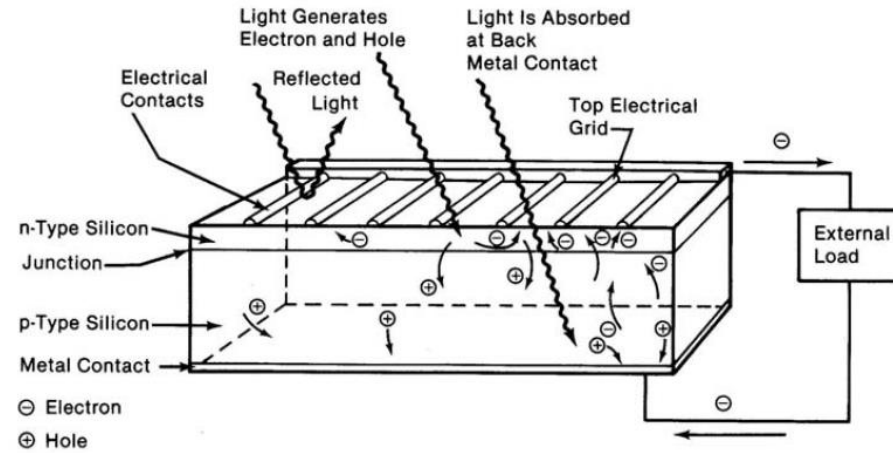

Basic photovoltaic principles and methods, 1981.

- Voltage and current depend on material
 - e.g. crystalline Si $V=0.6$ V, $i=35$ mA/m²
 - High voltage: in series
 - High current: large area

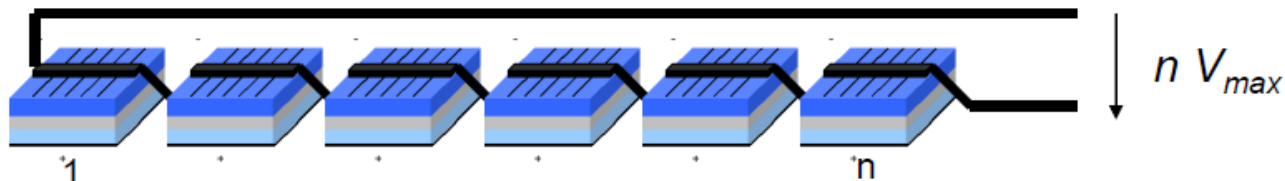

Working principle

- PV cell:
 - Characteristics changes with irradiation, temperature, and age

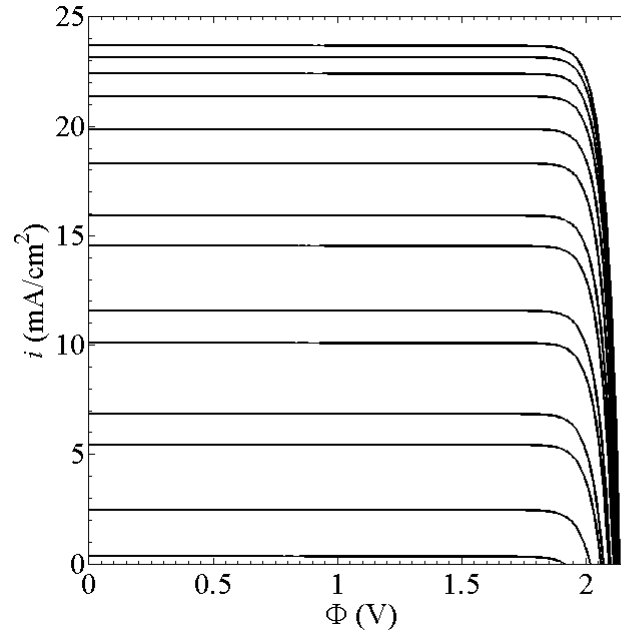

- Maximum power point tracker (MPPT):
 - high efficiency DC to DC converter that presents an optimal electrical load to a solar panel or array, produces a voltage suitable for the load (e.g. a battery system or an a DC/AC converter).
- Most common use “perturb and observe” algorithm

Working principle

- PV cell:
 - For grid usage, use inverter (electrical device that converts DC to AC current).
 - For PV inverters usually include an MPPT tracker and additional functions such as voltage/frequency stability, fault ride through capability, anti-islanding



SMA, «Sunny boy», 3kW



Solaron PV inverters, 500 kW, installed at a 35 MW PV plant, near Coalinga, CA



Efficiency

- PV material choice: availability

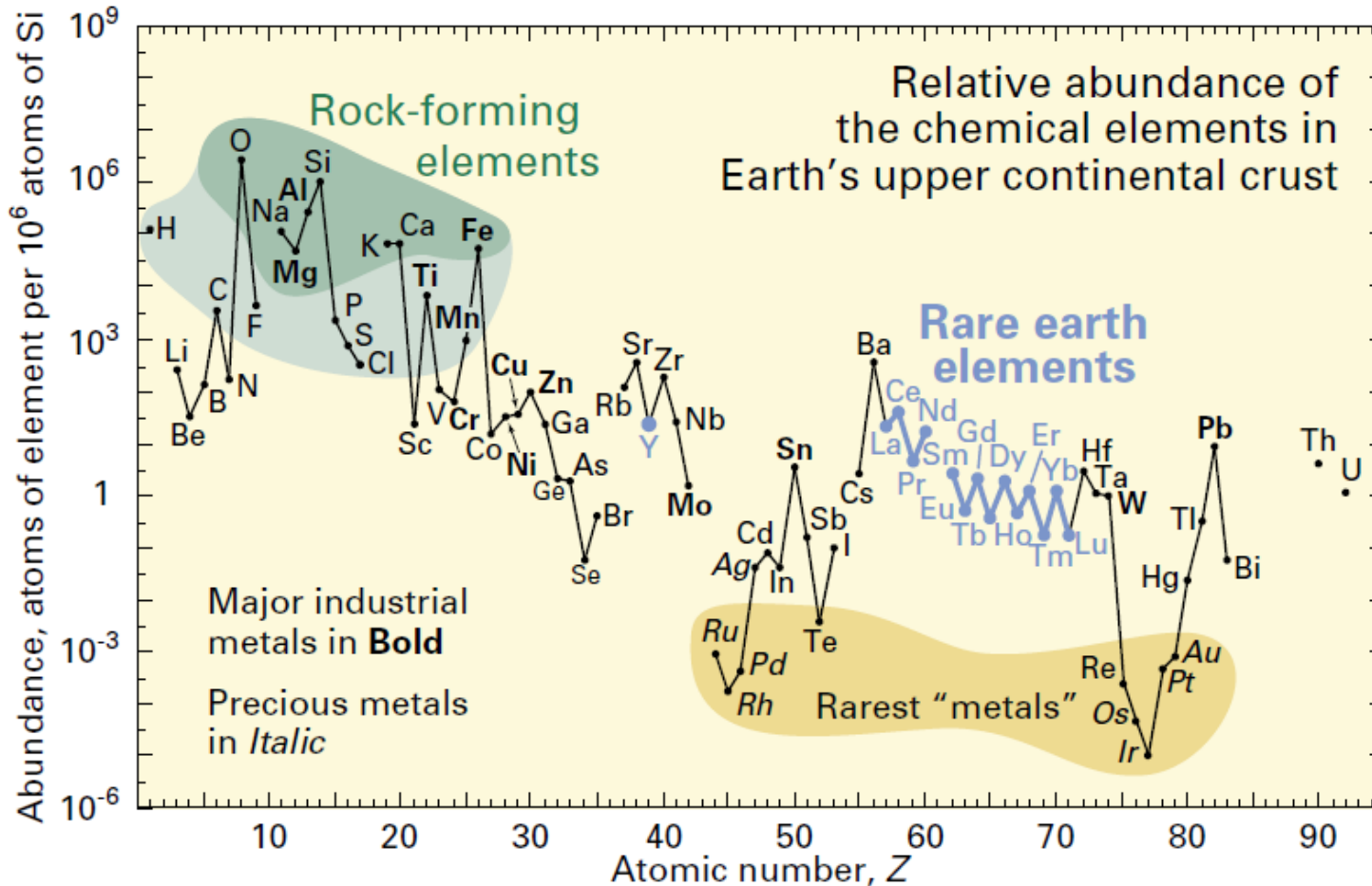

US Geological Survey, Fact Sheet 2002

Efficiency

- PV material choice:

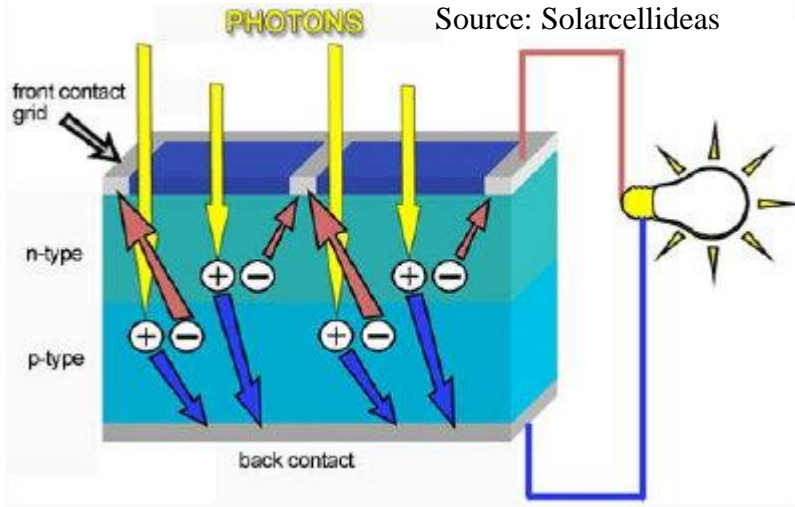

$$E_{\text{photon}} = \frac{hc}{\lambda} \quad E_{\text{gap}} = \frac{hc}{\lambda_{\text{gap}}}$$

$$c = 3 \times 10^8 \text{ m/s}$$

$$h = 6.63 \times 10^{-34} \text{ J s}$$

$$1 \text{ eV} = 1.6 \times 10^{-19} \text{ J}$$

Material	E_G in eV	
Ge	0.7	→ $\lambda_G = 1.78 \mu\text{m}$
CuInSe ₂	1	
Si	1.13	→ $\lambda_G = 1.13 \mu\text{m}$
GaAs	1.42	
CdTe	1.45	
AlSb	1.55	
CuGaSe ₂	1.7	
a Si (amorph)	1.7	
Al _{0.85} Ga _{0.15} As	1.9	
GaP	2.3	
CdS	2.45	→ $\lambda_G = 0.51 \mu\text{m}$

Efficiency

- PV: simple efficiency calculations

$$\swarrow F_{0-\lambda T}$$

Material	E_G [eV]	λ_G [mm]	useful [%]	not useful [%]
Ge	0.7	1.78	91.94	8.06
CuInSe2	1	1.24	81.84	18.16
Si	1.13	1.10	76.62	23.38
GaAs	1.42	0.88	64.12	35.88
CdTe	1.45	0.86	62.81	37.19
AlSb	1.55	0.80	58.45	41.55
CuGaSe2	1.7	0.73	52.05	47.95
a Si	1.7	0.73	52.05	47.95
AlGaAs	1.9	0.65	43.98	56.02
GaP	2.3	0.54	30.12	69.88
CdS	2.45	0.51	25.80	74.20

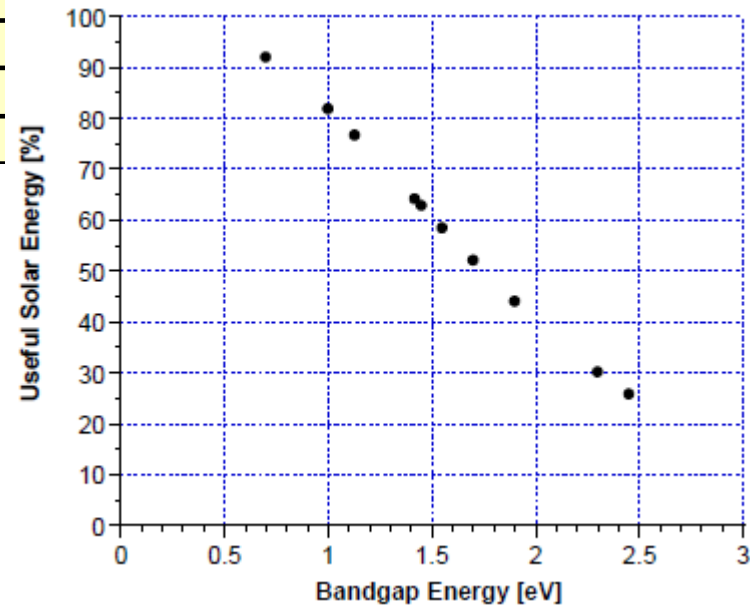

Efficiency

- PV: simple efficiency calculations
 - But for wavelengths smaller than band gap wavelength, not all energy useful for charge generation

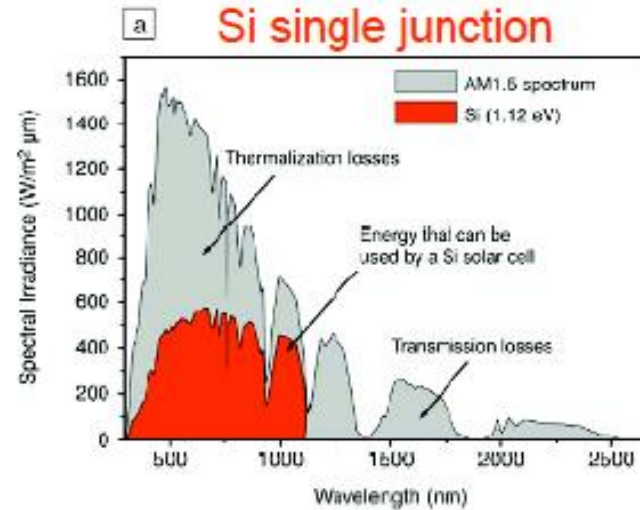

- Consequently, efficiency is given by:

$$\eta = \frac{\int_0^{\lambda_g} \frac{E_g}{E} e_{\lambda b} d\lambda}{\int_0^{\infty} e_{\lambda b} d\lambda} = \frac{1}{\sigma T^4} \int_0^{\lambda_g} \frac{E_g}{E} e_{\lambda b} d\lambda \approx \frac{1}{\sigma T^4} \sum_{i=1}^N \int_{\lambda_i}^{\lambda_{i+1}} \frac{E_g}{E_{\lambda_{m,i}}} e_{\lambda b} d\lambda = \sum_{i=1}^N \frac{E_g}{E_{\lambda_{m,i}}} F_{\lambda_i - \lambda_{i+1}}$$

↑
 Mean wavelength in i -th band

Efficiency

- PV: simple efficiency calculations – Example Si, $E_g=1.1$ eV

Efficiency

- PV theoretical efficiencies
 - Theoretical efficiency limit by Shockley and Queisser, 1961

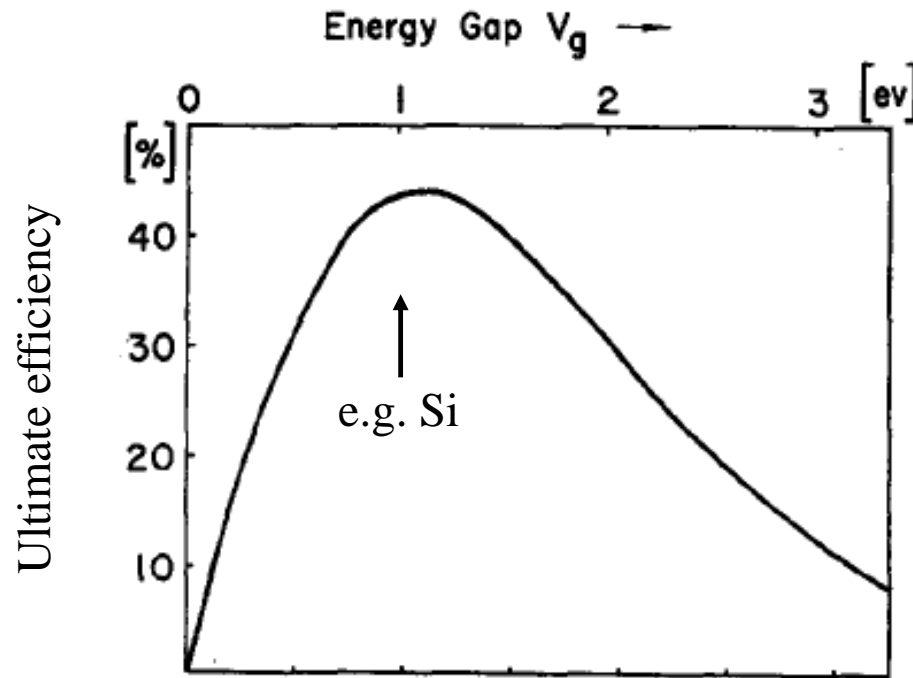

Efficiency

- Efficiency:
 - Temperature dependence:
 - Decrease in band gap energy
 - Slight increase in I_{sc}
 - But decrease in V_{oc}

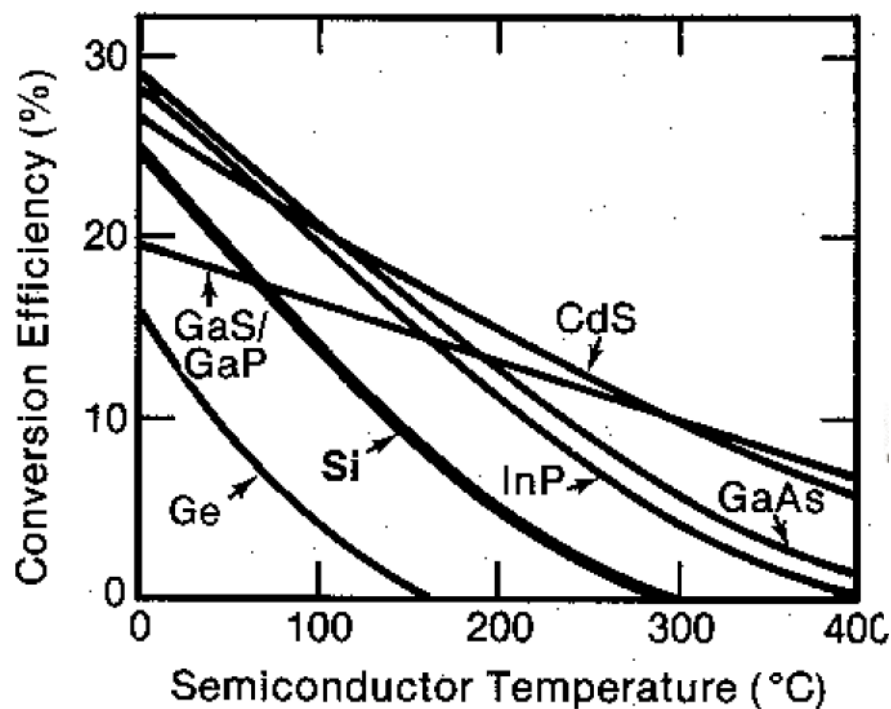
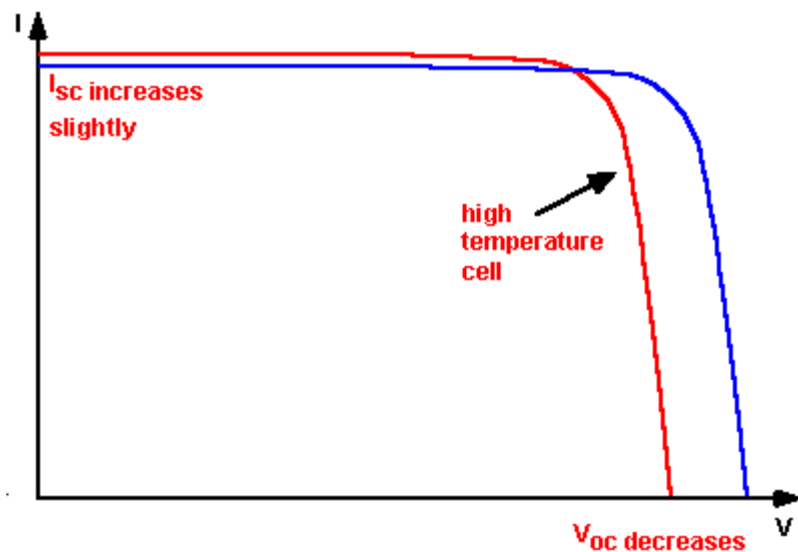

Basic photovoltaic principles and methods, 1981.

Efficiency

- Efficiency:
 - Concentration dependent:
 - I_{sc} linearly increases with concentration (no effect on efficiency)
 - V_{oc} increases logarithmically

Efficiency

- Efficiency:
 - Realistically also to consider:
 - Surface reflection
 - Opacity of current collectors
 - Limited thickness
 - Limited minority carrier lifetime
 - Material quality (e.g. crystal boundaries)
 - Series resistance of cell
 - Shunt resistance of cell
 - Irradiation condition (spectral changes, directional changes)

Efficiency

- PV cell with higher efficiency:
 - Multi-layers with different materials:

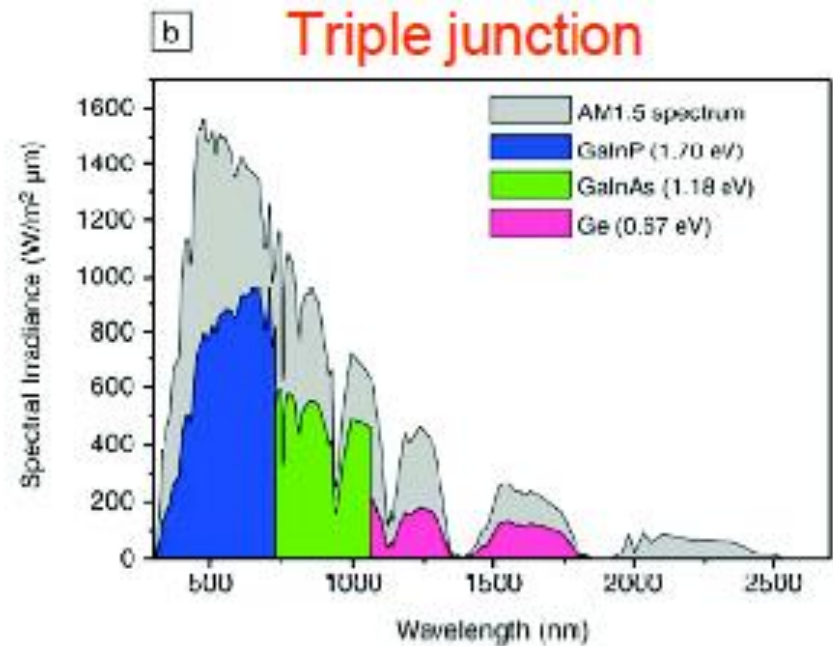
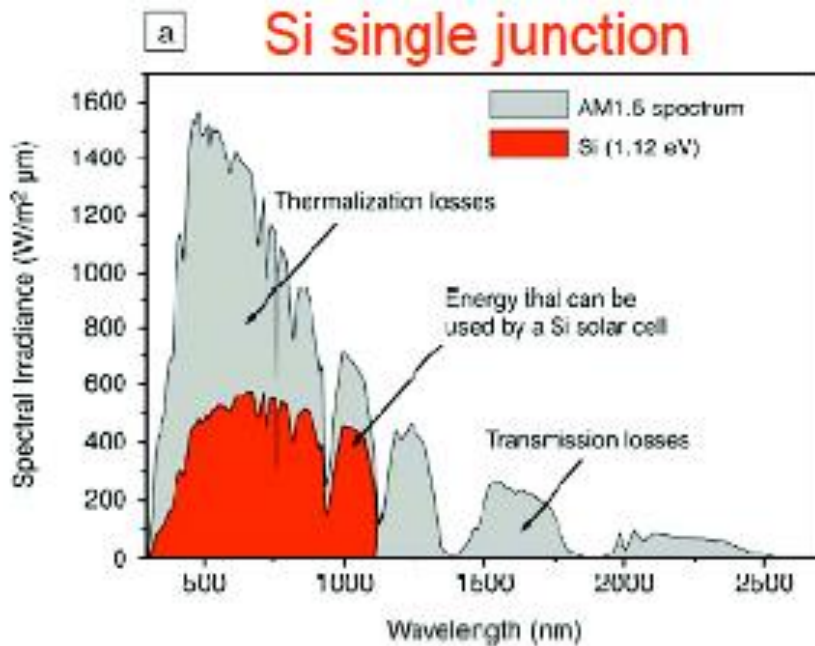

- In series, connected with tunnel junctions: try to be current matching!

Efficiency

- Measurement of efficiency:
 - Standard test conditions (*STC*), Module at 25 °C, spectrum AM1.5G (global), light intensity 1000 W/m²

- Efficiency:
$$\eta = \frac{P_{\max}}{P_{in}} \Big|_{STC}$$

- Modules are sold according to W or W_p (= W peak), with respect to 1000 W/m² (AM1.5G)

- Rule of thumb: in CH or Germany 1 W_p of modules give 1 kWh per year (corresponds roughly to 1000 hours of full sun, i.e. 1x1000 = 1kWh)

- <http://re.jrc.ec.europa.eu/pvgis/apps4/pvest.php>

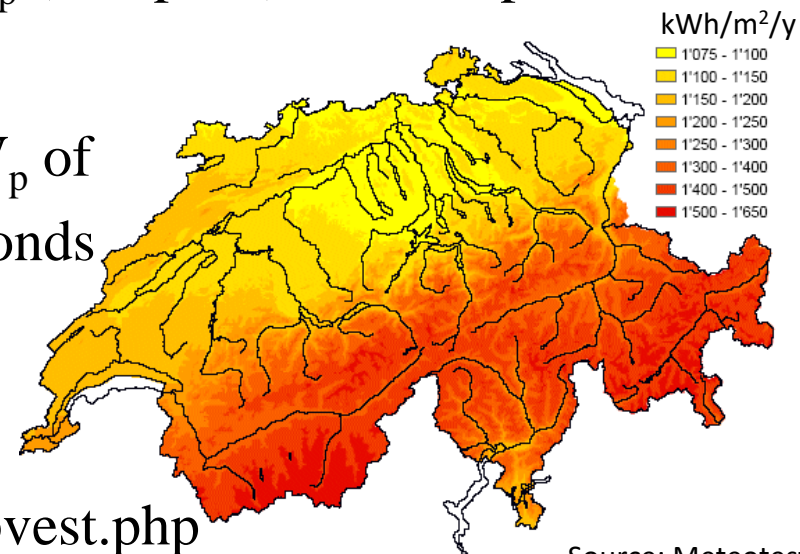

Technologies

- Photovoltaics: Technologies and market

Crystalline silicon

Mono and multicrystalline

Status: main market share

Thin films

CIGS, CdTe, Thin film silicon

Status: stabilised market share

Market

Concentrator technologies

Mostly III-V based

Status: trying entering the market, many start-ups

Emerging technologies

Nano inorganic
Organic-Polymer
Dye sensitized and variation
Status: niche application

Novel PV concepts

Quantum dots, intermediate band, ...
Status: attempt of demonstration

Ballif, PV-lab, EPFL

Technologies

- Efficiencies of various technologies

Best Research-Cell Efficiencies

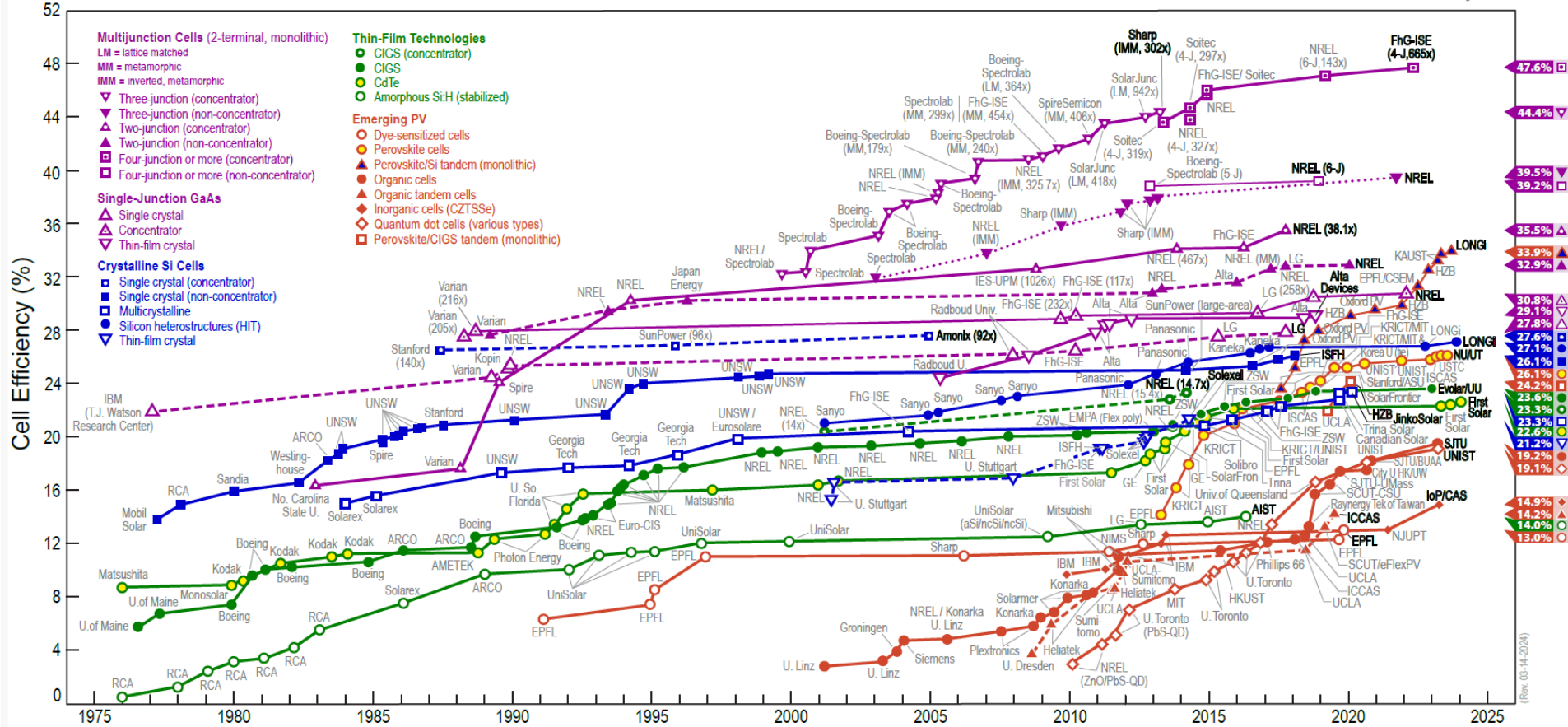

<https://www.nrel.gov/pv/cell-efficiency.html>

Technologies

- Efficiencies of various technologies:
 - Crystalline (Si: mono and poly):
 - Efficiency: 16-23%
 - Potential: 20-25%
 - Thin film (CdTe, CIGS a-Si / $\mu\text{c-Si}$):
 - Efficiency: 14-16%
 - Potential: 16-20%
 - Concentrated (III-V-based):
 - Efficiency: 25-30%
 - Potential: 30-50%



Technologies

- Market shares:

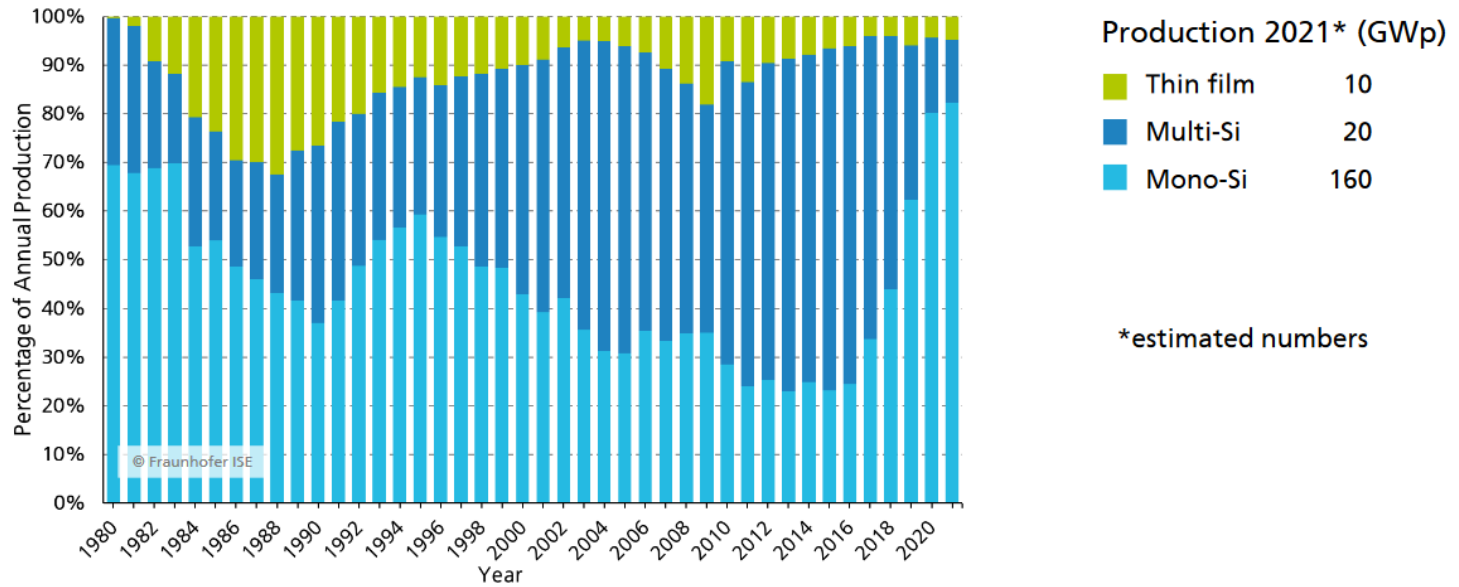

Data: from 2000 to 2009: Navigant; from 2010 to 2021 IHS Markit; from 2022 IEA. Graph: PSE 2022. Date of data: July 2022

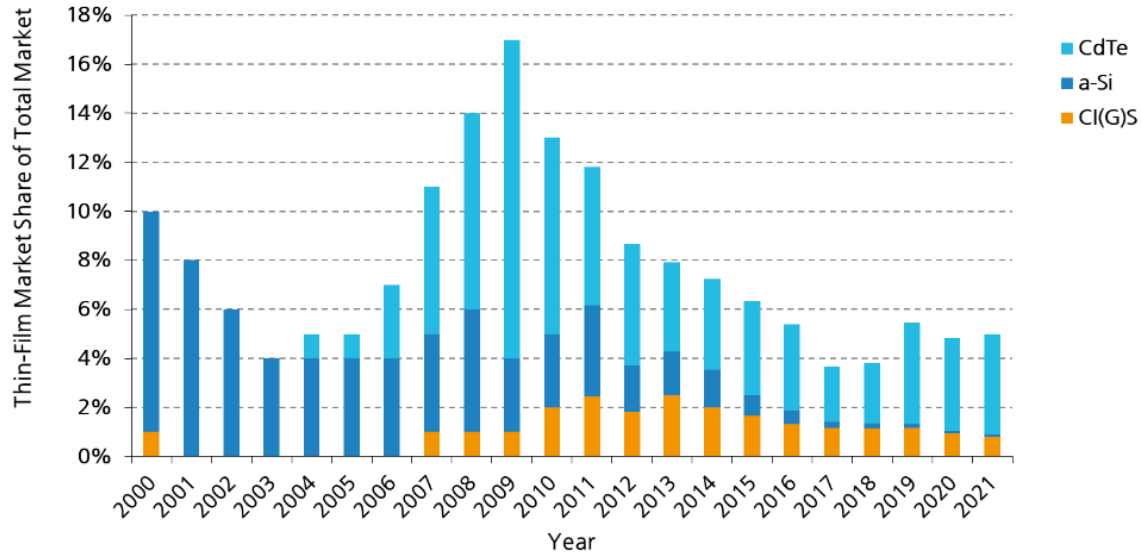

Data: from 2000 to 2009: Navigant; from 2010 to 2021 IHS Markit; from 2022 IEA. Graph: PSE 2022. Date of data: July 2022

Technologies

- Crystalline Silicon: Manufacturing
 - Get the raw material (SiO_2)
 - Produce high quality material by carbothermal reduction:
 $\text{SiO}_2 + \text{C} \rightarrow \text{Si} + \text{CO}_2$, 98.7% pure, 1-3 CHF/kg
and Siemens process:
 $\text{Si} + \text{HCl} \rightarrow \text{SiHCl}_3 + \text{H}_2$, and distillation, 2ppb impurity
 $2\text{SiHCl}_3 \rightarrow \text{Si} + 2\text{HCl} + \text{SiCl}_4$, «solar grade», 0.1ppb impurity, 15 CHF/kg
 - Dopping of the material (often p-doping)
 - If monocrystalline quality needed: Czochralski process or edge-defined film-fed growth
 - Sawing

Technologies

- Crystalline Si: Manufacturing

- Czochralski process

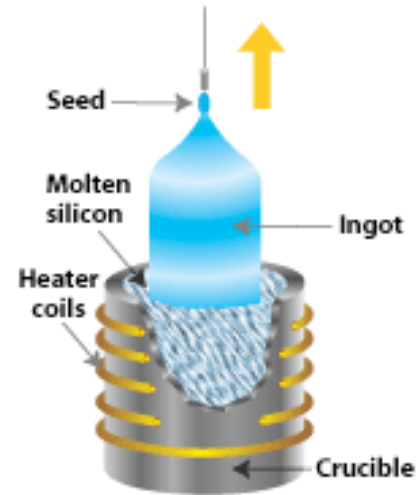

- Edge-defined film-fed growth (RWE Schott Solar, 2005)



Technologies

- Crystalline Silicon: Manufacturing
 - Chemical surface attacking with hot HF or NaOH
 - texturing of surface ($20\mu\text{m}$) to reduce surface reflection (40% reflection reduced to about 15%)
 - Doping (n-doping): diffusion of phosphorous into surface
 - „printing“ of the contacts and „electron connector“ grid (often in a single assembly line, automatic)
 - Printing of back contacts (Al, Ag, ...)
 - Potential additional antireflection coating on front
 - Assembling of panel, sealing and transportation

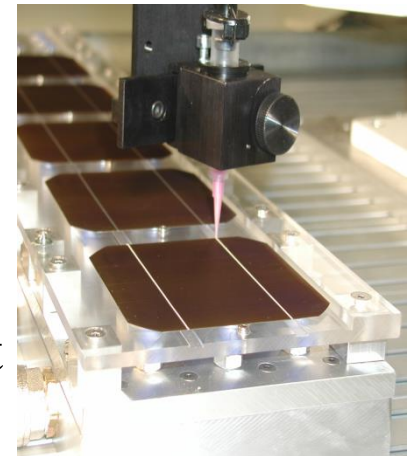

Technologies

- Photovoltaics:

- Crystalline silicon:

- Processing of wafers

- Series connection of individual solar cells

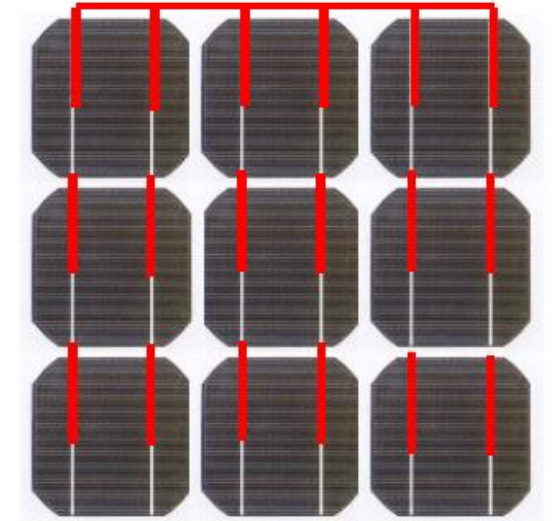

- Thin film:

- Depositions on large area substrate

- “monolithic series integration” of the cells (typically by lasering)

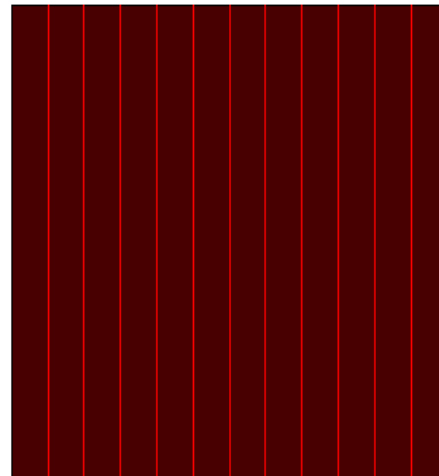

Technologies

- Concentrated PV:
 - Expensive solar cells can be cut and light concentrated
 - Good heat management required (because of V_{oc} and FF decrease with temperature)
 - The more you concentrate, the lower the acceptance angle

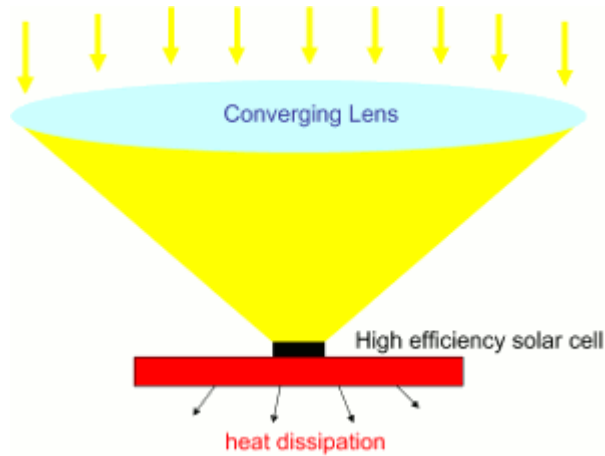

Technologies

- Organic solar cells, e.g. dye sensitized solar cells
 - Based on excitation of electron from a dye attached to a titania nanoparticles network, and fast transfer of electron to titania
 - Electron conduction through electrolyte solution
- Based on Brian O'Regan and Michael Grätzel, 1991, A low-cost, high-efficiency solar cell based on dye-sensitized colloidal TiO₂ films, *Nature* **353** (6346): 737–740.

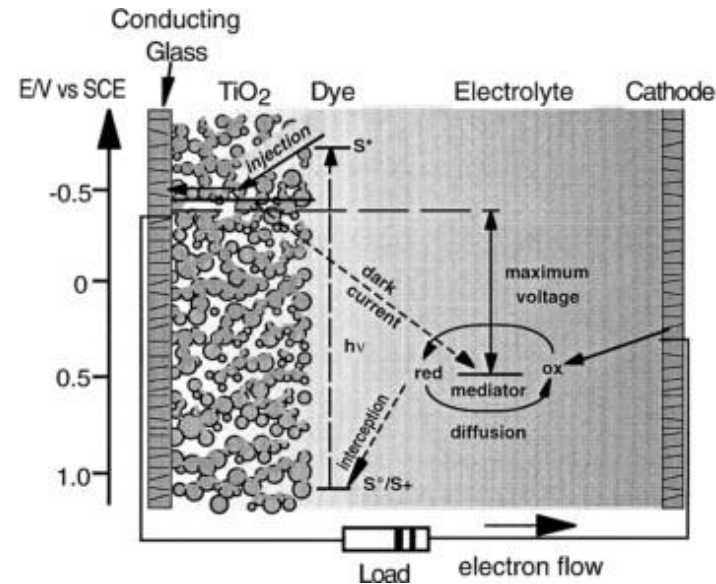

Technologies



Production and Installation

- Production

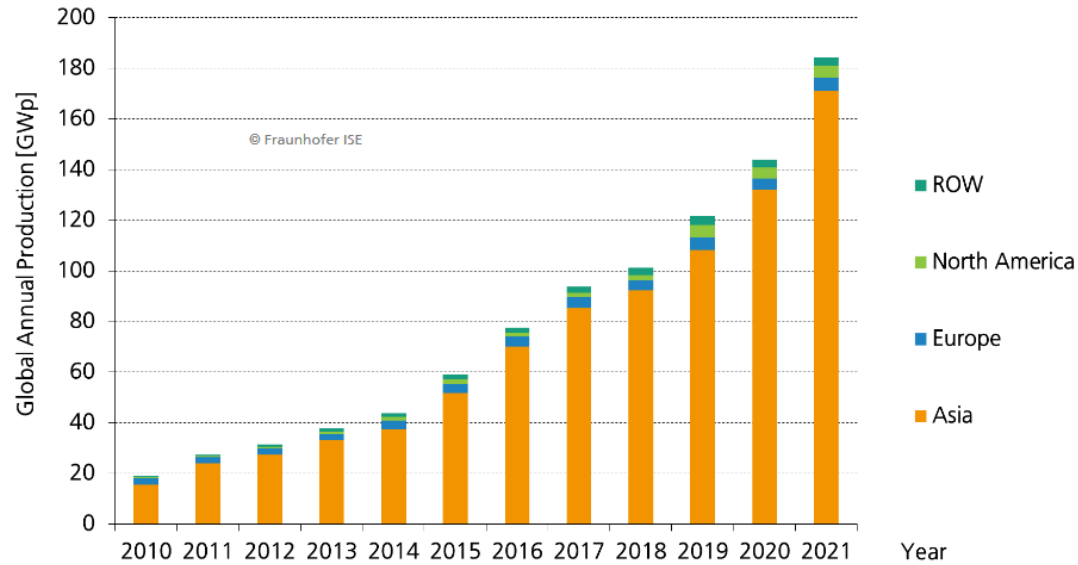

Data: Until 2020 IHS Markit; IEA 2021. Graph: PSE 2021; Date of data: 31-July 2022

- Installation

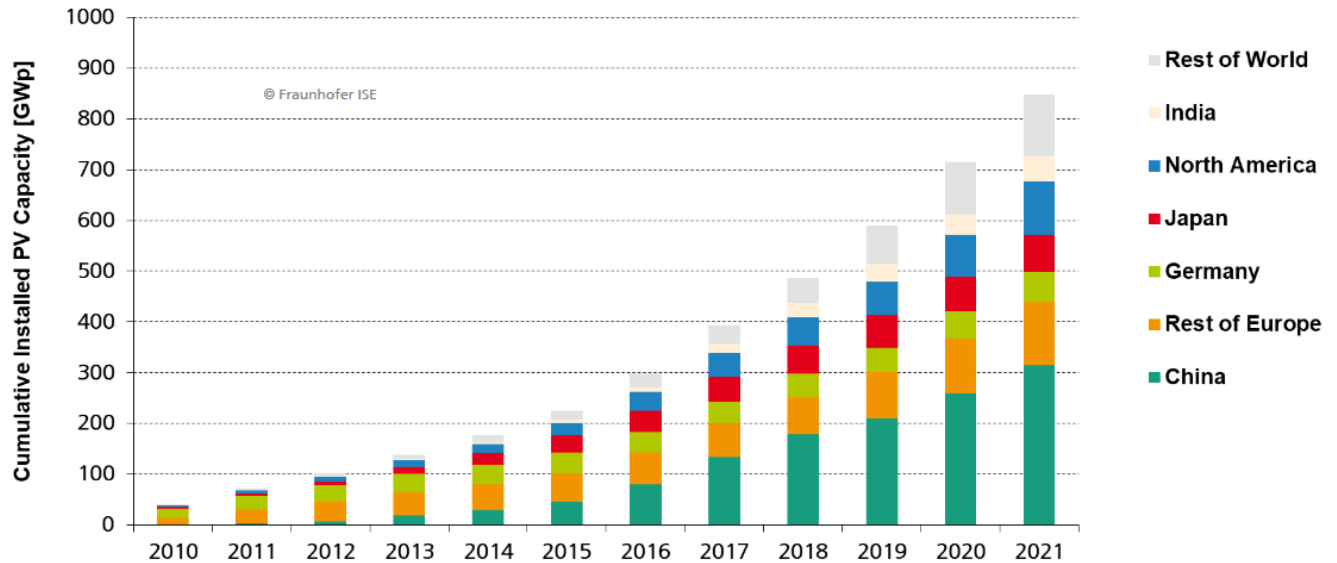

Data: IRENA 2022. Graph: PSE 2022. Date of data: Apr-2022

Cost

- Photovoltaics: Learning curve

Includes all commercially available technologies:

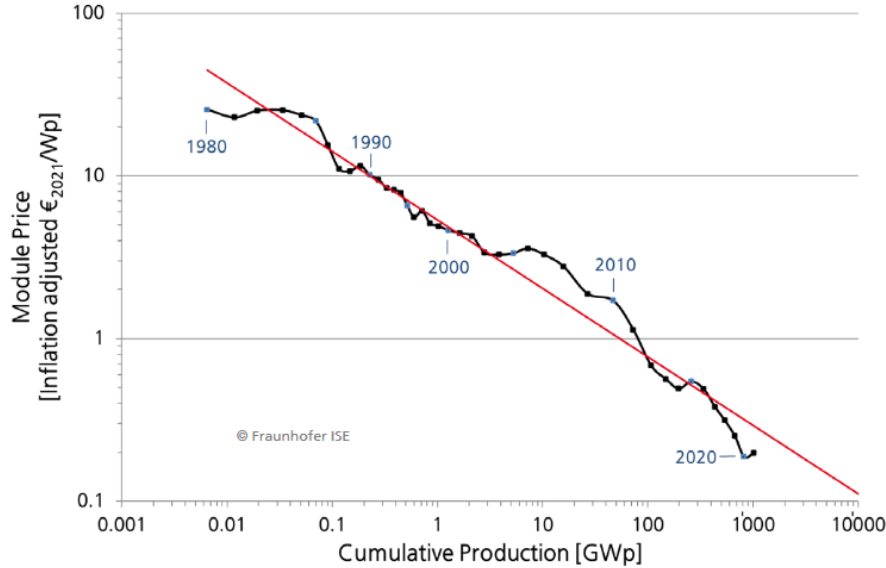

Data: from 1980 to 2010 estimation from different sources: Strategies Unlimited, Navigant Consulting, EUPD, pvXchange; from 2011: IHS Markit; Graph: PSE 2022

Learning Rate:

Each time the cumulative PV module production doubled the price went down by about 25% for the last 41 years.

Estimated cumulative PV module production up to Q4-2021:

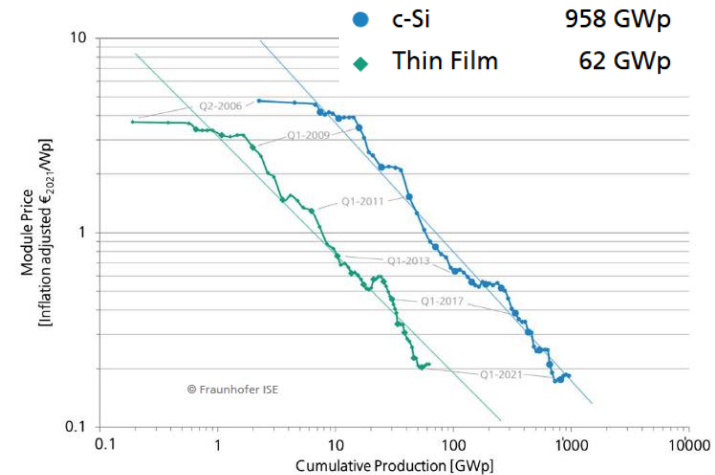

Data: from 2006 to 2010 estimation from different sources: Navigant Consulting, EUPD, pvXchange; from 2011: IHS Markit. Graph: PSE 2022

- Price for a Si-based module: $\sim 1 \text{ €/W}_p$, $\sim 150 \text{ €/m}^2$

Sustainability

- Photovoltaics: Life cycle assessment - Technology

Global Irrad.: 1925 kWh/m²/yr, Direct Normal Irrad.: 1794 kWh/m²/yr

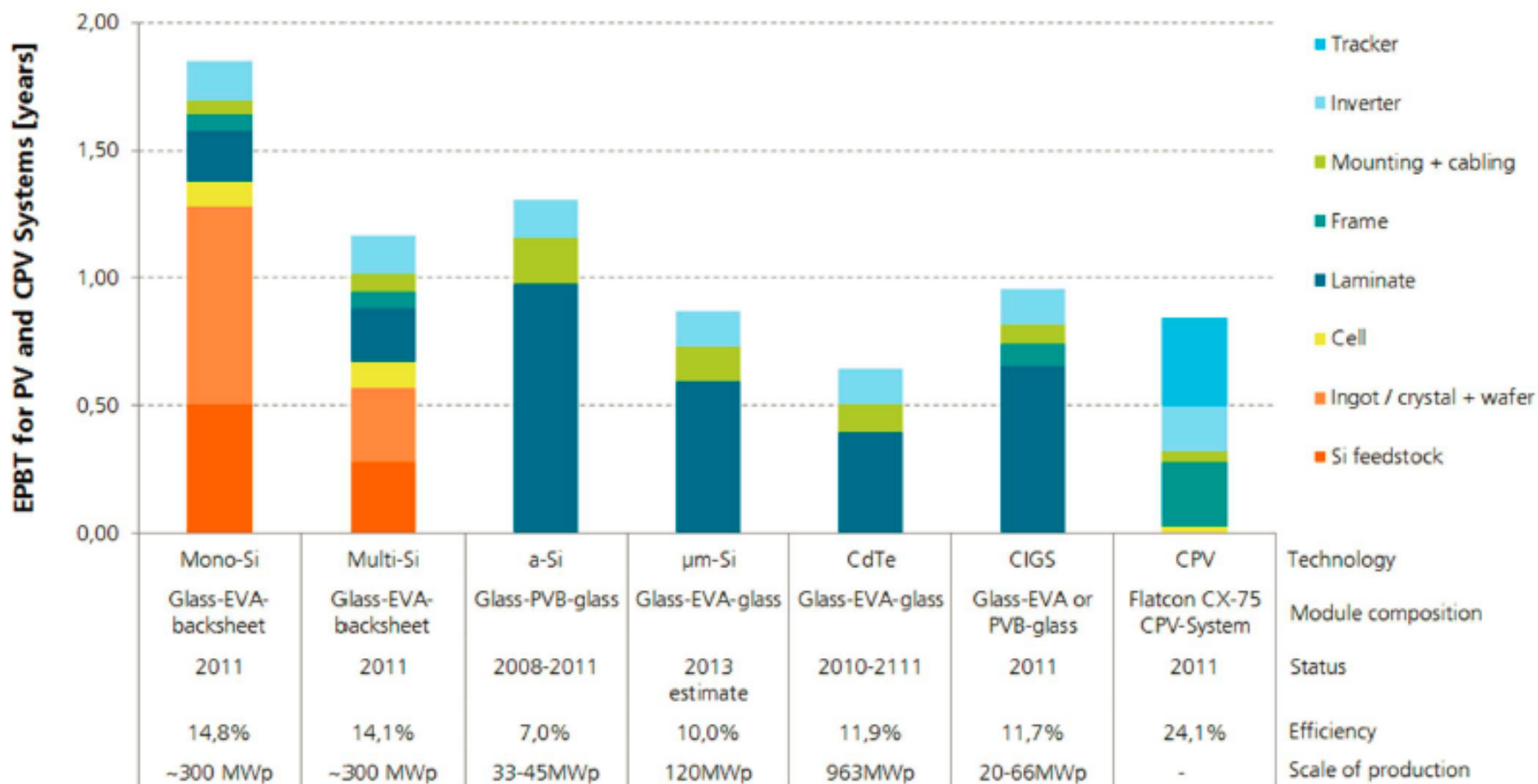

Data: M.J. de Wild-Scholten 2013; CPV data: "Environmental Sustainability of Concentrator PV Systems: Preliminary LCA Results of the Apollon Project" 5th World Conference on PV Energy Conversion. Valencia, Spain, 6-10 September 2010. Graph: PSE AG 2014

Sustainability

- Photovoltaics: Life cycle assessment - Location

Si PV rooftop, Cz PERC cells module with 19.9% efficiency

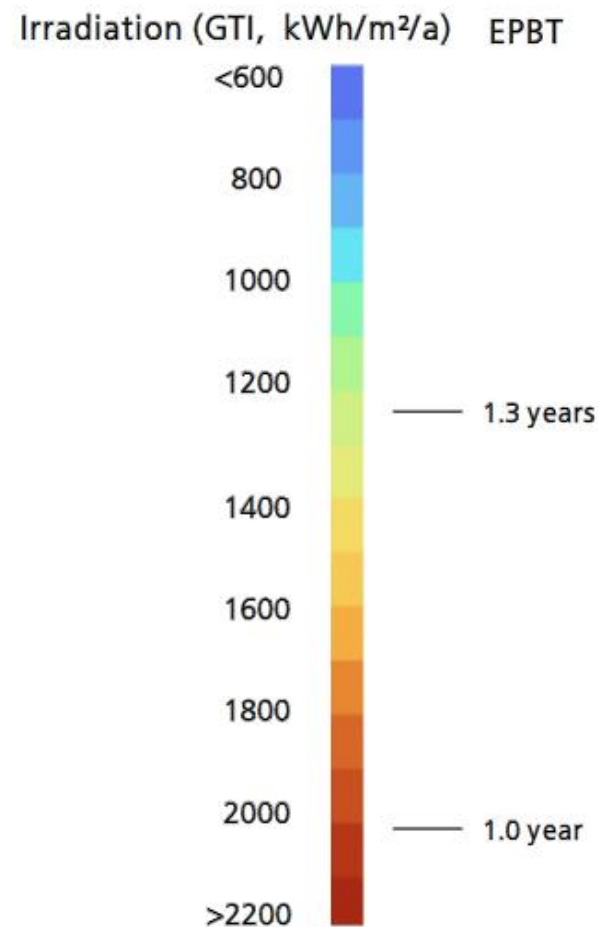
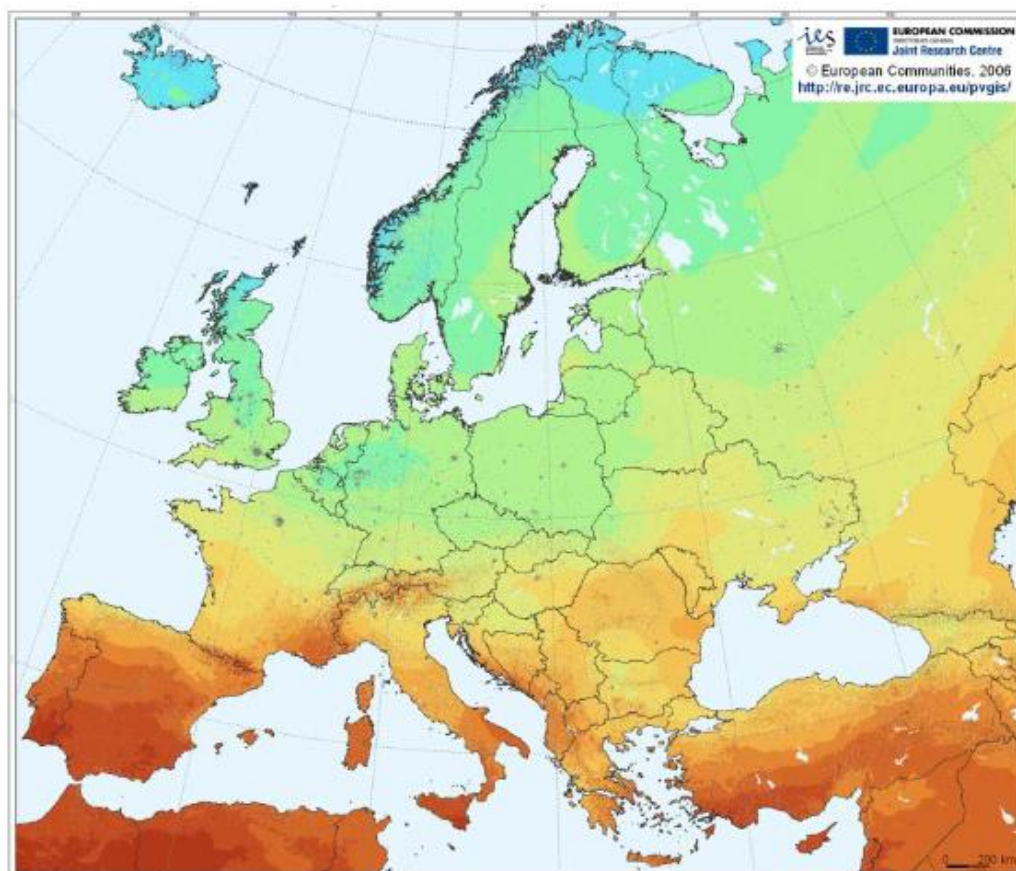

Aesthetics

- Photovoltaics: early modules



- Fully integrated today:



Aesthetics

- Photovoltaics: various colors

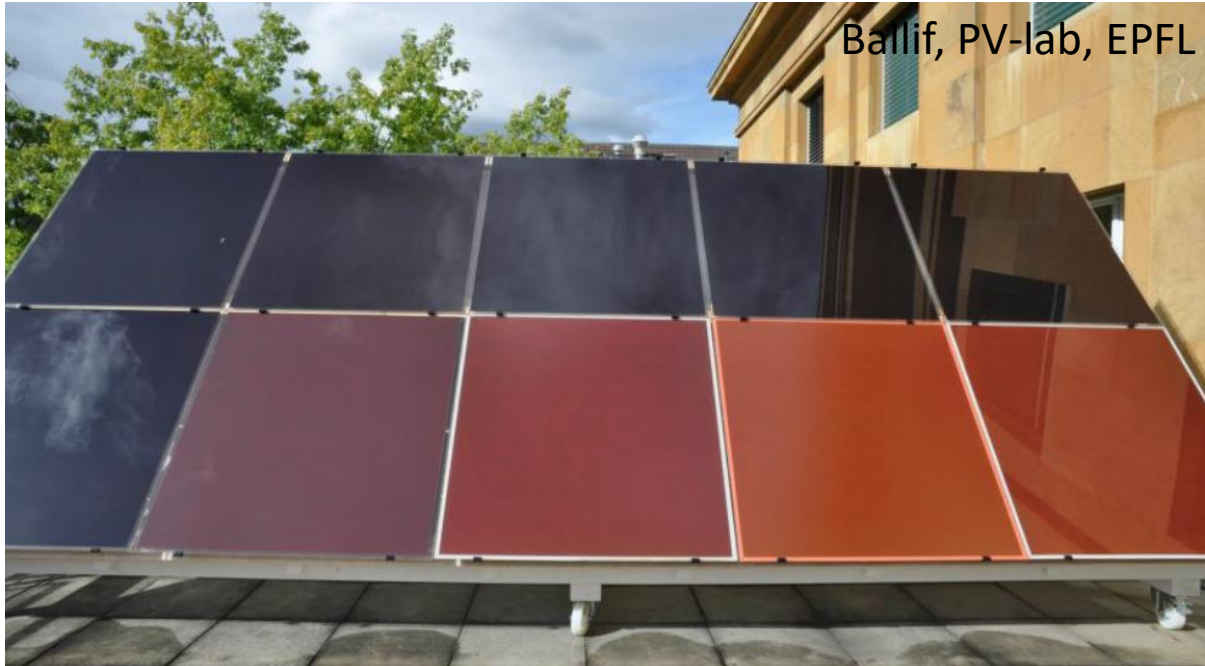

- Covered by prints



Learning outcomes of today's lecture

- Solar to electricity via PV:
 - Working principle of photovoltaic cell
 - Efficiency calculation for ideal cell
 - What influences efficiency (operating conditions)
 - Materials and their influence on efficiency
 - Overview of various PV technologies
 - Current efficiencies and potential
 - Differences, advantages and disadvantages

Literature

- Web:
 - pveducation.org
- Books:
 - A. Goetzberger, *Sonnenergie: Photovoltaik*, Teubner, Stuttgart (1997)
 - Da Rosa: *Fundamentals of Renewable Energy Processes*, Elsevier, 2005.